



# **SELF ASSESSMENT REPORT (SAR)**

**FOR FIRST TIME ACCREDITATION OF  
UNDERGRADUATE ENGINEERING PROGRAM (TIER-II)  
(Mechanical Engineering)**



**JAIPUR ENGINEERING COLLEGE AND RESEARCH CENTRE**  
Shri Ram Ki Nangal, Via Sitapura, RIICO  
OPP. EPIP Gate, Tonk Road  
Jaipur 302022  
September-2018



**SAR Contents**

<b><u>Serial Code &amp; Link to the Item</u></b>	<b>Item</b>	<b>Page No.</b>
<b>PART A</b>	<b>Institutional Information</b>	1
<b>PART B</b>	<b>Mechanical Engineering Criteria Summary</b>	9
<b>Program Level Criteria</b>		
1	Vision, Mission and Program Educational Objectives	10
2	Program Curriculum and Teaching – Learning Processes	28
3	Course Outcomes and Program Outcomes	131
4	Students’ Performance	175
5	Faculty Information and Contributions	205
6	Facilities and Technical Support	230
7	Continuous Improvement	283
<b>Institute Level Criteria</b>		
8	First Year Academics	304
9	Student Support Systems	358
10	Governance, Institutional Support and Financial Resources	475
<b>PART C</b>	<b>Declaration by the Institution</b>	614
<b>Annexure-I</b>	<b>Program Outcomes(POs) &amp; Program Specific Outcomes(PSOs)</b>	615



**Part A: Institutional Information**

1. Name and Address of the Institution : Jaipur Engineering College and Research Centre, Jaipur  
Shri Ram Ki Nangal, Via Sitapura, RIICO, OPP. EPIP  
Gate, Tonk Road, Jaipur 302022

2. Name and Address of the Affiliating University : Rajasthan Technical University, Kota  
and Akelgarh Rawatbhata Road, Kota 324010

3. Year of establishment of the Institution : 2000

4. Type of Institution:

University	<input type="checkbox"/>
Deemed University	<input type="checkbox"/>
Government Aided	<input type="checkbox"/>
Autonomous	<input type="checkbox"/>
Affiliated	<input type="checkbox" value="Yes"/>

5. Ownership Status:

Central Government	<input type="checkbox"/>
State Government	<input type="checkbox"/>
Government Aided	<input type="checkbox"/>
Self Financing	<input type="checkbox" value="Yes"/>
Trust	<input type="checkbox"/>
Society	<input type="checkbox"/>
Section 25 Company	<input type="checkbox"/>
Any Other (Please Specity)	<input type="checkbox"/>

## [SELF ASSESSMENT REPORT]



### 6. Other Academic Institutions of the Trust/Society /Company etc, if any

Name of the Institutions (S)	Year of Establishment	Programs of Study	Location
JECRC UDML College of Engineering	Establishment 2007 Year of Closure 2014	CE, CSE, ECE, IT, ME	Kukas, Jaipur
JECRC University	2012	School of Engineering, School of Law, School of Design, School of Hotel Management, School of Management, School of Science and Humanities.	Goner Road, Ramchandrapura, Jaipur

### 7. Details of all the programs being offered by the Institution Under Consideration:

#### 1<sup>st</sup> Shift

S. No	Program Name (B.Tech)	Year	Intake	Increase Intake, if any	Year of Increase	AICTE approval	Accreditation Status
1	Electrical Engineering-60	2000	180	-	-	13.07.2000	-
	Electronics & Communication Engineering-60						
	Computer Science and Engineering-60						
2	Electrical Engineering-60	2001	240	IT-60	2001	14.06.2001	-
	Electronics & Communication Engineering-60						
	Computer Science and Engineering-60						
	Information Technology-60						
3	Electrical Engineering-60	2002	300	Biotech-30 CSE-90	2002	20.06.2002	-
	Electronics & Communication Engineering-60						
	Computer Science and Engineering-90						
	Information Technology-60						
	Biotech-30						

## [SELF ASSESSMENT REPORT]



4	Electrical Engineering-60	2003	360	ME-60	2003	12.05.2003	-
	Electronics & Communication Engineering-60						
	Computer Science and Engineering-90						
	Information Technology-60						
	Biotech-30						
	Mechanical Engineering-60						
5	Electrical Engineering-60	2004	420	ECE-30 CSE-30	2004	25.06.2004	-
	Electronics & Communication Engineering-90						
	Computer Science and Engineering-120						
	Information Technology-60						
	Biotech-30						
	Mechanical Engineering-60						
6	Electrical Engineering-60	2005	420	-	-	27.06.2005	-
	Electronics & Communication Engineering-90						
	Computer Science and Engineering-120						
	Information Technology-60						
	Biotech-30						
	Mechanical Engineering-60						
7	Electrical Engineering-60	2006	420	-	-	20.06.2006	-
	Electronics & Communication Engineering-90						
	Computer Science and Engineering-120						
	Information Technology-60						
	Biotech-30						
	Mechanical Engineering-60						
8	Electrical Engineering-60	2007	420	-	-	21.05.2007	-
	Electronics & Communication Engineering-90						
	Computer Science and Engineering-120						
	Information Technology-60						
	Biotech-30						

## [SELF ASSESSMENT REPORT]



	Mechanical Engineering-60						
9	Electrical Engineering-30	2008	420	ECE-30 IT-30 <b>Decrease-</b> EE-30 Biotech-30	-	22.07.2008	-
	Electronics & Communication Engineering-120						
	Computer Science and Engineering-120						
	Information Technology-90						
	Mechanical Engineering-60						
10	Civil Engineering-60	2009	540	EE-30 ME-30 CE-60	2009	23.08.2010	2 Branch (CSE & ECE) dated 02.03.2009
	Electrical Engineering-60						
	Electronics & Communication Engineering-120						
	Computer Science and Engineering-120						
	Information Technology-90						
	Mechanical Engineering-90						
11	Civil Engineering-60	2010	540	-	-	23.08.2010	2 Branch (CSE & ECE) dated 02.03.2009
	Electrical Engineering-60						
	Electronics & Communication Engineering-120						
	Computer Science and Engineering-120						
	Information Technology-90						
	Mechanical Engineering-90						
12	Civil Engineering-60	2011	600	ECE-60	2011	01.09.2011	2 Branch (CSE & ECE) dated 02.03.2009
	Electrical Engineering-60						
	Electronics & Communication Engineering-180						
	Computer Science and Engineering-120						
	Information Technology-90						
	Mechanical Engineering-90						
13	Civil Engineering-120	2012	750	CE-60 ECE-60 ME-30	2012	10.05.2012	-
	Electrical Engineering-60						
	Electronics & Communication Engineering-240						
	Computer Science and Engineering-120						
	Information Technology-90						

## [SELF ASSESSMENT REPORT]



	Mechanical Engineering-120						
14	Civil Engineering-120	2013	870	EE-60 CSE-60	2013	19.03.2013	-
	Electrical Engineering-120						
	Electronics & Communication Engineering-240						
	Computer Science and Engineering-180						
	Information Technology-90						
	Mechanical Engineering-120						
15	Civil Engineering-120	2014	870	-	-	02.07.2014	-
	Electrical Engineering-120						
	Electronics & Communication Engineering-240						
	Computer Science and Engineering-180						
	Information Technology-90						
	Mechanical Engineering-120						
16	Civil Engineering-120	2015	870	-	-	07.04.2015	-
	Electrical Engineering-120						
	Electronics & Communication Engineering-240						
	Computer Science and Engineering-180						
	Information Technology-90						
	Mechanical Engineering-120						
17	Civil Engineering-120	2016	870	-	-	05.04.2016	-
	Electrical Engineering-120						
	Electronics & Communication Engineering-240						
	Computer Science and Engineering-180						
	Information Technology-90						
	Mechanical Engineering-120						
18	Civil Engineering-120	2017	870	-	-	30.03.2017	-
	Electrical Engineering-120						
	Electronics & Communication Engineering-240						
	Computer Science and Engineering-180						
	Information Technology-90						

## [SELF ASSESSMENT REPORT]



	Mechanical Engineering-120						
19	Civil Engineering-120	2018	870	-	-	04.04.2018	CSE,ECE,ME Eligible and applying 1st time IT,EE,CE- Eligible but not applied
	Electrical Engineering-120						
	Electronics & Communication Engineering-240						
	Computer Science and Engineering-180						
	Information Technology-90						
	Mechanical Engineering-120						

### 2<sup>nd</sup> Shift

S. No	Program Name (B.Tech)	Year of Start	Intake	Increase Intake, if any	Year of Increase	AICTE approval	Accreditation
1	Mechanical Engineering-60	2012	60	-	-	10.05.2012	-
2	Computer Science and Engineering-60	2013	120	60	2013	19.03.2013	-
	Mechanical Engineering-60						
3	Computer Science and Engineering-60	2014	120	-	-	02.07.2014	-
	Mechanical Engineering-60						
4	Computer Science and Engineering-60	2015	120	-	-	07.04.2015	-
	Mechanical Engineering-60						
5	Computer Science and Engineering-60	2016	120	-	-	05.04.2016	-
	Mechanical Engineering-60						
6	Computer Science and Engineering-60	2017	120	-	-	30.03.2017	-
	Mechanical Engineering-60						
7	Computer Science and Engineering-60	2018	120	-	-	04.04.2018	CS & ME Eligible but not applied
	Mechanical Engineering-60						

Write Applicable One:

- Applying first time
- Granted Provisional Accreditation for two/three years for the period (specify period)
- Granted accreditation for 5/6 years for the period (specify period)
- No accredited (Specify visit dates, year)
- Withdrawn (Specify vision dates, year)



## [SELF ASSESSMENT REPORT]



- Not eligible for accreditation
- Eligible but not applied

8. Program to be Considered for Accreditation vide this application:

S. No	Program name
1	Computer Science and Engineering
2	Electronics & Communication Engineering
3	Mechanical Engineering

9. Total Number of employees in the Institution:

A. Regular\* Employee (Faculty and Staff)

Items		CAYp1 (2018-19) No. of Faculty	CAY (2017-18)		CAYm1 (2016-17)		CAYm2 (2015-16)	
			Min	Max	Min	Max	Min	Max
Faculty in Engineering	M	122	120	132	114	129	102	117
	F	58	57	71	56	61	39	61
Faculty in Math, Science & Humanities	M	10	9	14	13	17	15	17
	F	18	20	25	24	29	21	28
Non-Teaching Staff	M	111	91	106	87	100	81	93
	F	13	12	14	12	13	9	12

B. Contractual Staff Employees (Faculty and Staff): (Non Covered in Table A)

Items		CAYp1 (2018-19) No. of Faculty	CAY (2017-18)		CAYm1 (2016-17)		CAYm2 (2015-16)	
			Min	Max	Min	Max	Min	Max
Faculty in Engineering	M	0	7	7	7	7	6	6
	F	0	0	0	0	0	0	0
Faculty in Math, Science & Humanities	M	0	0	0	0	0	0	0
	F	0	0	0	0	0	0	0
Non-Teaching Staff	M	1	0	0	0	0	0	0
	F	0	0	0	0	0	0	0

## [SELF ASSESSMENT REPORT]



### 10. Total Number of Engineering Students:

Item	CAYp1 (2018-19)	CAY (2017-18)	CAYm1 (2016-17)	CAYm2 (2015-16)
Total No. of boys	3312	3457	3499	3410
Total No. of Girls	686	750	811	815
Total No. of Students	3998	4207	4310	4225

### 11. Vision of the Institution:

- To become a renowned centre of outcome based learning and work toward academic, professional, cultural and social enrichment of the lives of individuals and communities.

### 12. Mission of the Institution:

- Focus on evaluation of learning outcome and motivate students to inculcate research aptitude by project based learning.
- Identify based on informed perception of Indian, regional and global needs , the areas of focus and provide platform to gain knowledge and solutions.
- Offer opportunities for interaction between academia and industry.
- Develop human potential to its fullest extent so that intellectually capable and imaginatively gifted leaders can emerge in a range of professions.

### 13. Contact Information of the Head of the Institution and NBA Coordinator, If designated:

1. Name : Dr. Vinay Kumar Chandna
2. Designation : Principal
3. Mobile No. : 9891406784
4. Email ID : [principal@jecrcmail.com](mailto:principal@jecrcmail.com)

### 14. NBA Coordinator, if designated:

1. Name : Mr. Manish Jain
2. Designation : Dy. Director (Special Projects)
3. Mobile No. : 7229823455
4. Email ID : [dydirector.sp@jecrc.ac.in](mailto:dydirector.sp@jecrc.ac.in)

# [SELF ASSESSMENT REPORT]



## PART B: Criteria Summary

Name of the program: **Mechanical Engineering**

Criterion No.	Criteria	Marks
	<b>Program Level Criteria</b>	
1	Vision, Mission and Program Educational Objectives	60
2	Program Curriculum and Teaching – Learning Processes	120
3	Course Outcomes and Program Outcomes	120
4	Students' Performance	150
5	Faculty Information and Contributions	200
6	Facilities and Technical Support	80
7	Continuous Improvement	50
	<b>Institute Level Criteria</b>	
8	First Year Academics	50
9	Student Support Systems	50
10	Governance, Institutional Support and Financial Resources	120
	<b>Total</b>	<b>1000</b>



<b>CRITERION 1</b>	<b>Vision, Mission and Program Educational Objectives</b>	<b>60</b>
--------------------	---	-----------

## **1. VISION, MISSION AND PROGRAM EDUCATIONAL OBJECTIVES (60)**

### **1.1 State the Vision and Mission of Department and Institute (5)**

*(Vision statement typically indicates aspirations and Mission statement states the broad approach to achieve aspirations)*

*(Here Institute Vision and Mission statements have been asked to ensure consistency with the department Vision and Mission statements; the assessment of the Institute Vision and Mission will be taken up in Criterion 10)*

#### **Vision of Department of Mechanical Engineering**

The Mechanical Engineering Department strives to be recognized globally for outcome based technical knowledge and to produce quality human resource, who can manage the advance technologies and contribute to society.

#### **Mission of Department of Mechanical Engineering**

**M1.** To impart quality technical knowledge to the learners to make them globally competitive mechanical engineers.

**M2.** To provide the learners ethical guidelines along with excellent academic environment for a long productive career.

**M3.** To promote industry-institute relationship.

#### **Vision of Jaipur Engineering College and Research Centre**

To become a renowned centre of outcome based learning, and work towards academic, professional, cultural and social enrichment of the lives of individuals and communities.

#### **Mission of Jaipur Engineering College and Research Centre**

**M1.** Focus on evaluation of learning outcomes and motivate students to inculcate research aptitude by project based learning.

**M2.** Identify, based on informed perception of Indian, regional and global needs, areas of focus and provide platform to gain knowledge and solutions.

**M3.** Offer opportunities for interaction between academia and industry.

**M4.** Develop human potential to its fullest extent so that intellectually capable and imaginatively gifted leaders can emerge in a range of professions.



**Mapping of Institute Vision with Department Vision**

Vision of the Institute  Vision of the Department	To become a renowned centre of outcome based learning, and work towards academic, professional, cultural and social enrichment of the lives of individuals and communities.
The Mechanical Engineering Department strives to be recognized globally for outcome based technical knowledge and to produce quality human resource, who can manage the advance technologies and contribute to society.	H

**Justification:**

The above table shows the consistency of vision of institute with vision of the department. The reasons behind marking High and Medium are as follows:

Vision of the department is divided into keywords to check the correlation of the vision of the department with vision of the institute.

After taking the feedback from faculty members of the department if the consistency found is above 90%, (✓) is marked. If consistency is found between 75-90%, the particular block is left blank.

**Why High:**

If (✓) is marked in all blocks i.e. all the keywords of vision of the department are found consistent with the vision of institute so it must be rated high.

**Medium:**

If ✓ is marked in 50% or above blocks i.e. Vision of the department is moderately consistent with the vision of the institute.

**Justification of mapping of Institute vision with department Vision**

Vision of Institute  Keywords of vision of ME	To become a renowned centre of outcome based learning, and work towards academic, professional, cultural and social enrichment of the lives of individuals and communities.
Technical knowledge	✓
Quality human resource	✓
Contribute to society	✓



**Mapping of Institute Mission with Department Mission**

Mission of the Institute Mission of the Department	Focus on evaluation of learning outcomes and motivate students to inculcate research aptitude by project based learning.	Identify, based on informed perception of Indian, regional and global needs, areas of focus and provide platform to gain knowledge and solutions.	Offer opportunities for interaction between academia and industry.	Develop human potential to its fullest extent so that intellectually capable and imaginatively gifted leaders can emerge in a range of professions.
To impart quality technical knowledge to the learners to make them globally competitive mechanical engineers.	H	H	H	M
To provide the learners ethical guidelines along with excellent academic environment for a long productive career.	H	H	M	H
To promote industry-institute relationship.	M	H	H	H

**Justification:**

The above table shows the consistency of mission of institute with mission of the department.

The reasons behind marking High and Medium are as follows:

Mission of the department is divided into keywords and then correlation is checked with mission of institute.

After taking the feedback from all the faculty members of the department if the consistency found is above 90%, (✓) is marked. If consistency is found between 75-90%, the particular block is left blank.

**Why High:**

If (✓) is marked in all blocks i.e. all the keywords of mission of the department are found consistent with the mission of institute so it must be rated high.

**Medium:**

If ✓ is marked in 90% - 50% blocks i.e. mission of department is moderately consistent with

## [SELF ASSESSMENT REPORT]



the mission of the institute.

### Justification of mapping of Institute Mission with Department Mission 1

Mission of Institute  M1 of ME  Keywords	Focus on evaluation of learning outcomes and motivate students to inculcate research aptitude by project based learning.	Identify, based on informed perception of Indian, regional and global needs, areas of focus and provide platform to gain knowledge and solutions.	Offer opportunities for interaction between academia and industry.	Develop human potential to its fullest extent so that intellectually capable and imaginatively gifted leaders can emerge in a range of professions.
Quality technical knowledge	✓	✓	✓	
Globally competitive	✓	✓	✓	✓

### Justification of mapping of Institute Mission with Department Mission 2

Mission of Institute  M2 of ME  Keywords	Focus on evaluation of learning outcomes and motivate students to inculcate research aptitude by project based learning.	Identify, based on informed perception of Indian, regional and global needs, areas of focus and provide platform to gain knowledge and solutions.	Offer opportunities for interaction between academia and industry.	Develop human potential to its fullest extent so that intellectually capable and imaginatively gifted leaders can emerge in a range of professions.
Ethical guidelines		✓		✓
Excellent academic environment	✓	✓	✓	✓

### Justification of mapping of Institute Mission with Department Mission 3

Mission of Institute  M3 of ME  Keywords	Focus on evaluation of learning outcomes and motivate students to inculcate research aptitude by project based learning.	Identify, based on informed perception of Indian, regional and global needs, areas of focus and provide platform to gain knowledge and solutions.	Offer opportunities for interaction between academia and industry.	Develop human potential to its fullest extent so that intellectually capable and imaginatively gifted leaders can emerge in a range of professions.
Industry-institute relationship	✓	✓	✓	



## 1.2 State the Program Educational Objectives (PEOs) (5)

*(State the PEOs (3 to 5) of program seeking accreditation)*

**PEO1.** To provide students with the fundamentals of Engineering Sciences with more emphasis in Mechanical Engineering by way of analyzing and exploiting engineering challenges.

**PEO2.** To train students with good scientific and engineering knowledge so as to comprehend, analyze, design, and create novel products and solutions for the real life problems in Mechanical Engineering.

**PEO3.** To inculcate professional and ethical attitude, effective communication skills, teamwork skills, multidisciplinary approach, entrepreneurial thinking and an ability to relate Mechanical Engineering issues with social issues.

**PEO4.** To provide students with an academic environment aware of excellence, leadership, written ethical codes and guidelines, and the self-motivated life-long learning needed for a successful professional career in Mechanical Engineering.

**PEO5.** To prepare students to excel in Industry and Higher education by Educating Students along with High moral values and Knowledge in Mechanical Engineering.

## 1.3 Indicate where the Vision and Mission and PEOs are published and disseminated among stake holders (10)

*(Describe where (websites, curricula, posters etc.) the Vision, Mission and PEOs are published and detail the process which ensures awareness among internal and external stakeholders with effective process implementation)*

*(Internal stakeholders may include Management, Governing Board Members, faculty, support staff, students etc. and external stakeholders may include employers, industry, alumni, funding agencies, etc.)*

The Vision, Mission and PEOs are published and disseminated among:

- College Website: [www.jecrc.in](http://www.jecrc.in)
- Board of Governors meeting
- Board Room
- Placement office
- Alumni connect cell





- Professional bodies
- HoD office
- Staff Rooms
- Class Rooms
- Notice Boards
- Laboratories
- Department Library
- Magazines and Newsletters
- Course Files
- Lab Manuals
- Students
- Faculty Members
- Alumni
- Parents

### **1.4 State the process for defining the Vision and Mission of the Department, and PEOs of the Program (25)**

*(Articulate the process for defining the Vision and Mission of the department and PEOs of the program)*

With the active participation of HoD, faculty members and staff which are based on the continuous feedback from stakeholders develop the Vision and Mission statement of the department in alignment with Vision and Mission of the Institute.

- These statements are discussed further among faculty members before finalization.
- These statements are discussed among students also before finalization.
- These statements are discussed among stake holders also before finalization.
- The new Vision and Mission statements are sent to the Principal for approval.
- Our process for establishing and revising Department Vision, Department Missions and Program Educational Objectives (PEOs) are depicted in figures below. Faculty Members/Students/Stakeholders/Alumni inputs are obtained through surveys with follow-up email and telephone calls by the Department HoD and associated faculty members.
- This feedback is condensed and presented to faculty members at the final faculty members meeting.

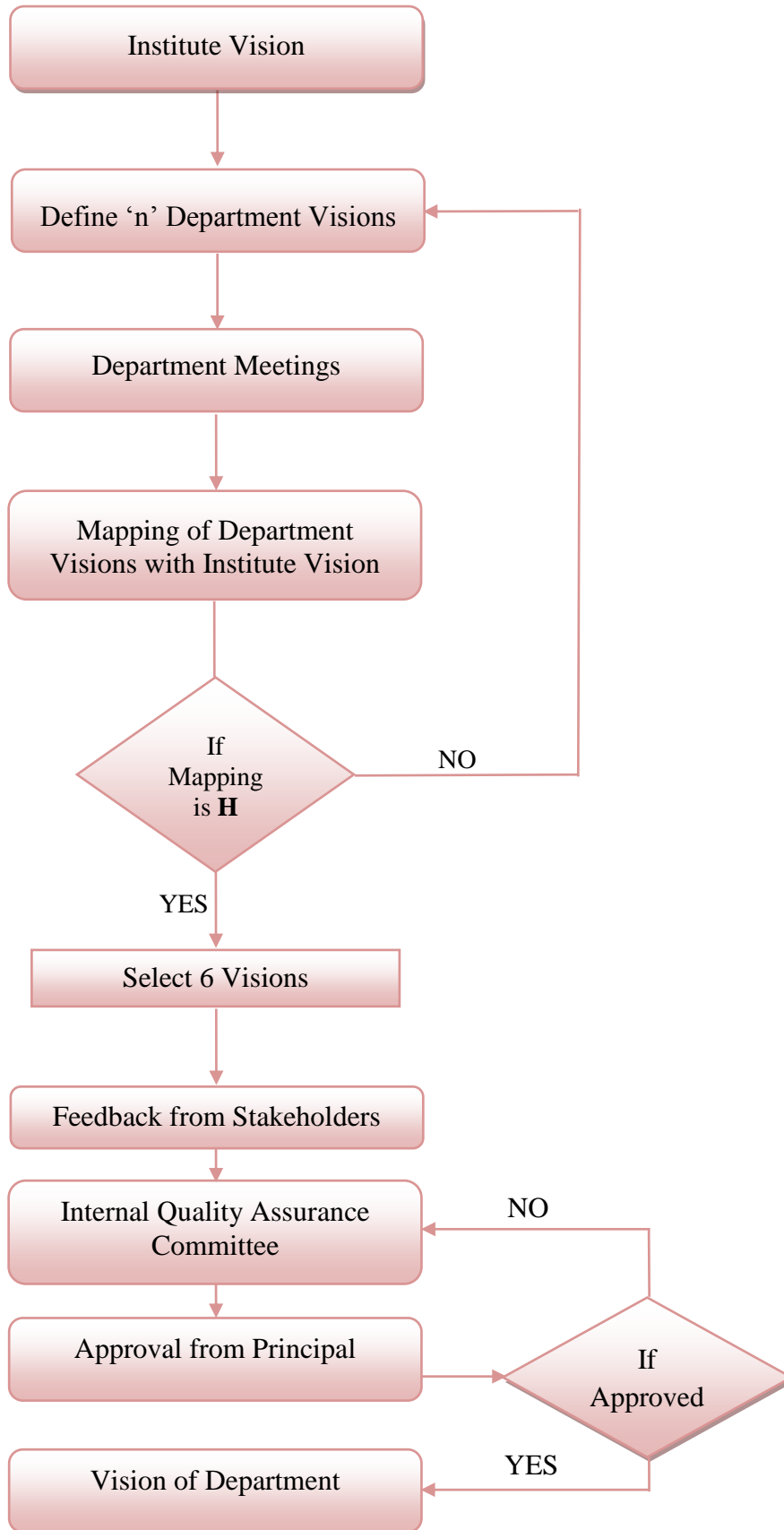

**Figure 1.1 Selection Process of Department Vision**

# [SELF ASSESSMENT REPORT]



Jaipur Engineering College and Research Centre, Jaipur  
Department of Mechanical Engineering  
Feedback of Vision

Department Vision ↓	Institute Vision →	To become a renowned center of outcome based learning, and work towards academic, professional, cultural and social enrichment of the lives of individuals and communities.
To be an internationally renowned institution of higher learning in research, innovation, publication and teaching.		M
To be recognized globally for outcome based technical knowledge and to produce quality human resource, who can manage the advance technologies and contribute to society.		H
To establish outcome based excellence in teaching, learning and commitment to support Industry.		H
To envisage an ambience of excellence, inspiring value based education, research and development in Mechanical Engineering with a commitment to train students with world-class competency and cutting-edge proficiency to face challenges of global market with confidence.		M
Through the excellence of its people, the Department of Mechanical Engineering will be recognized as a leader of its discipline in a manner that exemplifies the land-grant traditions of learning, discovery, and engagement.		M
To be a nationally recognized mechanical engineering department that attracts, rewards, and retains outstanding faculty, students, and staff.		H
To become a center of excellence in Mechanical Engineering, producing innovative and creative mechanical engineers to meet the global challenges.		M
To engage the students in academic as well as scholarly activities, which strengthen the department reputation in global market.		H
To impart quality education to the students and enhancing their skills to make them globally competitive Mechanical Engineers.		L
To be a nationally and internationally recognized research-oriented mechanical engineering department - a first choice for undergraduate and graduate education.		L

H: High related  
M: Medium related  
L: Low related

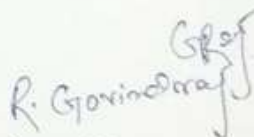
  
 Name and Signature

**FACULTY**

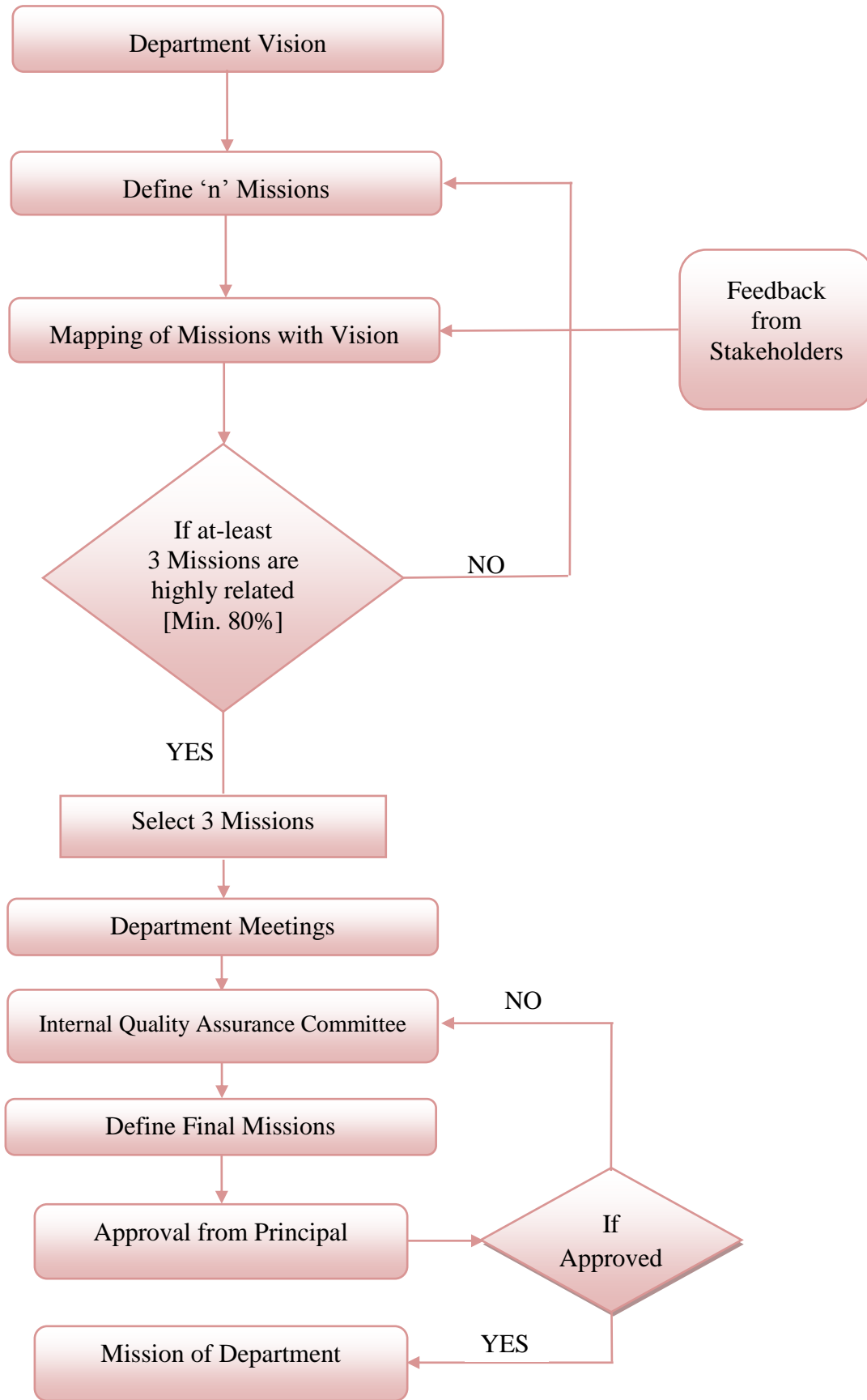

Figure 1.2 Selection Process of Department Missions

# [SELF ASSESSMENT REPORT]



Jaipur Engineering college & Research Centre, Jaipur

Department of Mechanical Engineering

Vision Evaluation Form

S.N.	Vision	5	4	3	2	1
1	To be an internationally renowned institution of higher learning in research, innovation, publication and teaching.		4			
2	The Mechanical Engineering Department strives to be recognized globally for outcome based technical knowledge and to produce quality human resource, who can manage the advance technologies and contribute to society.	5				
3	To establish outcome based excellence in teaching, learning and commitment to support Industry.			3		
4	To envisage an ambience of excellence, inspiring value based education, research and development in Mechanical Engineering with a commitment to train students with world-class competency and cutting-edge proficiency to face challenges of global market with confidence;				2	
5	Through the excellence of its people, the Department of Mechanical Engineering will be recognized as a leader of its discipline in a manner that exemplifies the land-grant traditions of learning, discovery, and engagement.		4			
6	Be a nationally recognized mechanical engineering department that attracts, rewards, and retains outstanding faculty, students, and staff	5				

*Subhash Yadav*

Subhash Yadav

Name & Signature

*Rej police (constable)*

Designation & Organization

**PARENT**

# [SELF ASSESSMENT REPORT]



Jaipur Engineering College and Research Centre, Jaipur  
 Department of Mechanical Engineering  
 Feedback of Mission

Department Mission ↑	Department Vision ←	↓ To be recognized globally for outcome based technical knowledge and to produce quality human resource, who can manage the advance technologies and contribute to society.
To impart quality technical knowledge to the learners to make them globally competitive mechanical engineers.		H
To provide the learners ethical guidelines along with excellent academic environment for a long productive career.		H
To educate the nation's future leaders in the science and art of mechanical engineering.		L
To promote industry-institute relationship.		H
To serve society through innovation and excellence in teaching and research.		M

H: High related  
 M: Medium related  
 L: Low related

*Ar. Swamy*  
 Acharya Dr. Sharan  
 Name and Signature  
 Batch - 2015

**ALUMNI**

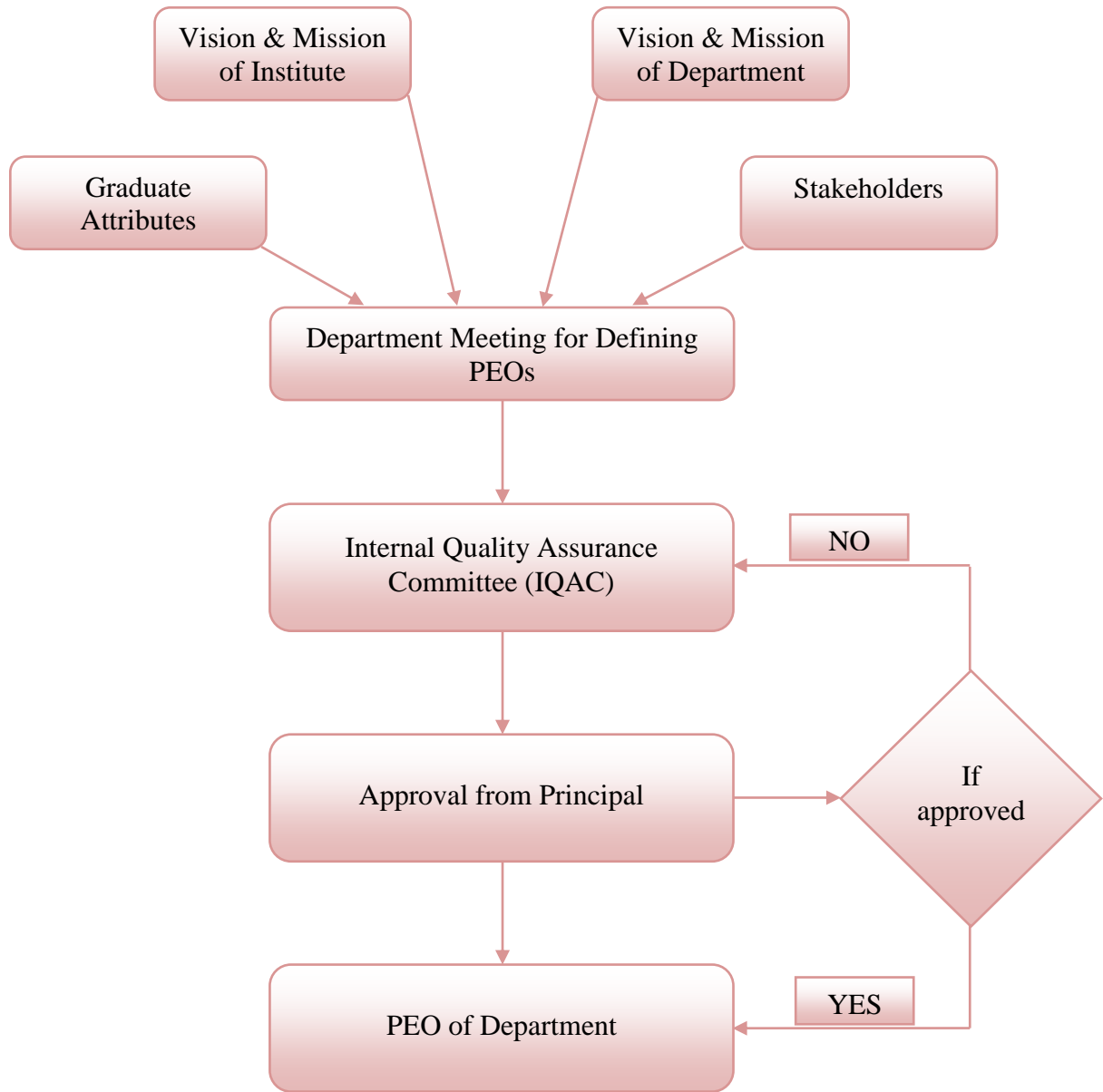

Figure 1.3 Selection Process of department PEOs

# [SELF ASSESSMENT REPORT]



## Jaipur Engineering College & Research Centre, Jaipur Department of Mechanical Engineering PEOs Evaluation Form

S#	Program Educational Objectives	5	4	3	2	1
1	To provide students with the fundamentals of Engineering Sciences with more emphasis in Mechanical Engineering by way of analyzing and exploiting engineering challenges.	✓				
2	Graduates will apply their engineering skills, exhibiting critical thinking and problem solving skills in professional engineering practices or tackle social, technical and business challenges.		✓			
3	Our graduates will contribute to the professional practice of their chosen field through effective communication, leadership, teamwork, and service, while exhibiting high ethical and professional standards.			✓		
4	To provide students with an academic environment aware of excellence, leadership, written ethical codes and guidelines, and the self-motivated life-long learning needed for a successful professional career.	✓				
5	Our graduates will apply high standards in the performance of their professional work regarding global and societal issues including health, safety, and the protection of the environment.		✓			
6	To inculcate professional and ethical attitude, effective communication skills, teamwork skills, multidisciplinary approach, entrepreneurial thinking and an ability to relate engineering issues with social issues.	✓				
7	To prepare students to excel in Industry and Higher education by Educating Students along with High moral values and Knowledge.	✓				
8	To produce graduates who are able to apply mechanical engineering knowledge to provide solution to national and international organizations.	✓				
9	Our graduates will continue life-long learning through professional activities and training, the pursuit of higher educational degrees, and individual professional improvement.	✓				
10	To train students with good scientific and engineering knowledge so as to comprehend, analyze, design, and create novel products and solutions for the real life problems.		✓			

Name & Signature

*Amit Kumar*

Designation & Organization

*Alumni (JECRC)*

**ALUMNI**



# [SELF ASSESSMENT REPORT]



## Jaipur Engineering College & Research Centre, Jaipur Department of Mechanical Engineering Mapping of PEOs and Mission Evaluation Form

Mission →	To impart quality technical knowledge to the learners to make them globally competitive mechanical engineers.	To provide the learners ethical guidelines along with excellent academic environment for a long productive career.	To promote industry-institute relationship.
PEOs ↓			
1. To provide students with the fundamentals of Engineering Sciences with more emphasis in Mechanical Engineering by way of analyzing and exploiting engineering challenges.	H	H	M
2. To train students with good scientific and engineering knowledge so as to comprehend, analyze, design, and create novel products and solutions for the real life problems.	H	M	H
3. To inculcate professional and ethical attitude, effective communication skills, teamwork skills, multidisciplinary approach, entrepreneurial thinking and an ability to relate engineering issues with social issues.	H	M	H
4. To provide students with an academic environment aware of excellence, leadership, written ethical codes and guidelines, and the self-motivated life-long learning needed for a successful professional career.	H	H	H
5. To prepare students to excel in Industry and Higher education by Educating Students along with High moral values and Knowledge.	M	H	H

Note: The above table shows the consistency of PEOs with Mission of the department. Kindly provide the marking as a. If you Agree >70% Mark 2 b. If you agree 50%-60% then mark 1 c. If your agreement is below 50% mark 0.

Name & Signature of (Student/Parent/Faculty) Sandeep Gupta  
(Industry) Sandeep  
Designation & Organization ( In case of Parents)/ Roll No. & Class ( In case of Students)  
HR, Jindal Steels, Gurgaon

**INDUSTRY PERSON**



**1.5 Establish Consistency of PEOs with Mission of the Department (15)**

*(Generate a “Mission of the Department – PEOs matrix” with justification and rationale of the mapping)*

**Mapping of PEOs with Missions**

<p align="center"><b>Mission</b></p> <p align="center">↓</p> <p align="center"><b>PEOs</b></p> <p align="center">→</p>	<p>To impart quality technical knowledge to the learners to make them globally competitive mechanical engineers.</p>	<p>To provide the learners ethical guidelines along with excellent academic environment for a long productive career.</p>	<p>To promote industry-institute relationship.</p>
<p>1. To provide students with the fundamentals of Engineering Sciences with more emphasis in Mechanical Engineering by way of analyzing and exploiting engineering challenges.</p>	<p><b>H</b></p>	<p><b>M</b></p>	<p><b>M</b></p>
<p>2. To train students with good scientific and engineering knowledge so as to comprehend, analyze, design, and create novel products and solutions for the real life problems in Mechanical Engineering.</p>	<p><b>H</b></p>	<p><b>M</b></p>	<p><b>M</b></p>
<p>3. To inculcate professional and ethical attitude, effective communication skills, teamwork skills, multidisciplinary approach, entrepreneurial thinking and an ability to relate Mechanical Engineering issues with social issues.</p>	<p><b>M</b></p>	<p><b>H</b></p>	<p><b>H</b></p>
<p>4. To provide students with an academic environment aware of excellence, leadership, written ethical codes and guidelines, and the self-motivated life-long learning needed for a successful professional career in Mechanical Engineering.</p>	<p><b>H</b></p>	<p><b>H</b></p>	<p><b>H</b></p>
<p>5. To prepare students to excel in Industry and Higher education by Educating Students along with High moral values and knowledge in Mechanical Engineering.</p>	<p><b>H</b></p>	<p><b>H</b></p>	<p><b>H</b></p>

**Table B.1.5 (a)**

## [SELF ASSESSMENT REPORT]



### **Justification:**

The above table shows the consistency of PEOs with Mission of the department. The reasons behind marking High, Medium and Low are as follows:

- PEO's are divided into keywords and then correlation is checked with all missions.
- After taking the feedback from all the faculty members of the department if the consistency found is above 90%, (✓) is marked. If consistency is found between 75-90%, the particular block is left blank.

### **Why High:**

If (✓) is marked in all blocks i.e. all the keywords of PEO are found consistent with the mission so it must be rated high.

### **Why Medium:**

If ✓ is marked in 50% or above blocks i.e. PEO is moderately consistent with the mission of the department.

<b>Justification of mapping of PEO 1 with Mission</b>			
Mission  PEO 1 Keywords	To impart quality technical knowledge to the learners to make them globally competitive mechanical engineers.	To provide the learners ethical guidelines along with excellent academic environment for a long productive career.	To promote industry-institute relationship.
Fundamentals of Engineering Sciences.	✓	-	-
Analyzing and exploiting engineering challenges.	✓	✓	✓
<b>Justification of mapping of PEO 2 with Mission</b>			
Mission  PEO 2 Keywords	To impart quality technical knowledge to the learners to make them globally competitive mechanical engineers.	To provide the learners ethical guidelines along with excellent academic environment for a long productive career.	To promote industry-institute relationship.
Good scientific and engineering knowledge.	✓	✓	-
Create novel products and solutions for the real life problems.	✓	-	✓

## [SELF ASSESSMENT REPORT]



<b>Justification of mapping of PEO 3 with Mission</b>			
Mission  PEO 3 Keywords	To impart quality technical knowledge to the learners to make them globally competitive mechanical engineers.	To provide the learners ethical guidelines along with excellent academic environment for a long productive career.	To promote industry-institute relationship.
Professional and ethical attitude.	-	✓	✓
Communication skills, teamwork skills.	✓	✓	✓
Multidisciplinary approach.	✓	✓	✓
Entrepreneurial thinking.	-	✓	✓
Relate engineering issues with social issues.	✓	✓	✓
<b>Justification of mapping of PEO 4 with Mission</b>			
Mission  PEO 4 Keywords	To impart quality technical knowledge to the learners to make them globally competitive mechanical engineers.	To provide the learners ethical guidelines along with excellent academic environment for a long productive career.	To promote industry-institute relationship.
Academic environment aware of excellence, leadership, written ethical codes.	✓	✓	✓
Successful professional career.	✓	✓	✓
Self-motivated life-long learning.	✓	✓	✓



Justification of mapping of PEO 5 with Mission			
Mission	To impart quality technical knowledge to the learners to make them globally competitive mechanical engineers.	To provide the learners ethical guidelines along with excellent academic environment for a long productive career.	To promote industry-institute relationship.
PEO 5 Keywords			
Excel in Industry and Higher education.	✓	✓	✓
High moral values and Knowledge.	✓	✓	✓

*Table B.1.5 (a)*

# [SELF ASSESSMENT REPORT]



<b>CRITERION 2</b>	<b>Program Curriculum and Teaching – Learning Processes</b>	<b>120</b>
--------------------	---	------------

## 2. PROGRAM CURRICULUM AND TEACHING - LEARNING PROCESSES (120)

### 2.1 Program Curriculum (20)

Jaipur Engineering College and Research Centre is affiliated to Rajasthan Technical University, Kota. The course curriculum of mechanical engineering has been provided by the university.

<b>Teaching &amp; Examination Scheme</b> <b>Session 2018-19</b> <b>I Semester B. Tech.</b> <b>Common to all branches of UG Engineering &amp; Technology</b>										
SN	Category	Course Code	Course Title	Hours			Marks			Cr
				L	T	P	IA	ETE	Total	
1	BSC	1FY2-01	Engineering Mathematics-I	3	1	-	40	160	<b>200</b>	<b>4</b>
2	BSC	1FY2-02/ 1FY2-03	Engineering Physics/ Engineering Chemistry	3	1	-	40	160	<b>200</b>	<b>4</b>
3	HSMC	1FY1-04/ 1FY1-05	Communication Skills/ Human Values	2	-	-	20	80	<b>100</b>	<b>2</b>
4	ESC	1FY3- 06/1FY3- 07	Programming for Problem Solving/ Basic Mechanical Engineering	2	-	-	20	80	<b>100</b>	<b>2</b>
5	ESC	1FY3- 08/1FY3- 09	Basic Electrical Engineering/ Basic Civil Engineering	2	-	-	20	80	<b>100</b>	<b>2</b>
6	BSC	1FY2- 20/1FY2- 21	Engineering Physics Lab/ Engineering Chemistry Lab	-	-	2	30	20	<b>50</b>	<b>1</b>
7	HSMC	1FY1- 22/1FY1- 23	Language Lab/ Human Values Activities	-	-	2	30	20	<b>50</b>	<b>1</b>
8	ESC	1FY3- 24/1FY3- 25	Computer Programming Lab/ Manufacturing Practices Workshop	-	-	3	45	30	<b>75</b>	<b>1.5</b>
9	ESC	1FY3- 26/1FY3- 27	Basic Electrical Engineering Lab/ Basic Civil Engineering Lab	-	-	2	30	20	<b>50</b>	<b>1</b>

# [SELF ASSESSMENT REPORT]



10	ESC	1FY3-28/1FY3-29	Computer Aided Engineering Graphics/ Computer Aided Machine Drawing	-	-	3	45	30	75	1.5
11	SODECA	1FY8-00							25	0.5
<b>Total</b>									<b>1025</b>	<b>20.5</b>

**L** = Lecture, **T** = Tutorial,  
**P** = Practical, **IA** = Internal Assessment,  
**ETE** = End Term Exam, **Cr** = Credits

**Teaching & Examination Scheme  
 Session 2018-19  
 II Semester B. Tech.  
 Common to all branches of UG Engineering & Technology**

SN	Category	Course Code	Course Title	Hours			Marks			Cr
				L	T	P	IA	ETE	Total	
1	BSC	1FY2-01	Engineering Mathematics-II	3	1	-	40	160	200	4
2	BSC	1FY2-03/ 1FY2-02	Engineering Chemistry/ Engineering Physics	3	1	-	40	160	200	4
3	HSMC	1FY1-05/ 1FY1-04	Human Values/ Communication Skills	2	-	-	20	80	100	2
4	ESC	1FY3-07/1FY3-06	Basic Mechanical Engineering/ Programming for Problem Solving	2	-	-	20	80	100	2
5	ESC	1FY3-09/1FY3-08	Basic Civil Engineering/ Basic Electrical Engineering	2	-	-	20	80	100	2
6	BSC	1FY2-21/1FY2-20	Engineering Chemistry Lab/ Engineering Physics Lab	-	-	2	30	20	50	1
7	HSMC	1FY1-23/1FY1-22	Human Values Activities/ Language Lab	-	-	2	30	20	50	1
8	ESC	1FY3-25/1FY3-24	Manufacturing Practices Workshop/ Computer Programming Lab	-	-	3	45	30	75	1.5
9	ESC	1FY3-27/1FY3-26	Basic Civil Engineering Lab/ Basic Electrical Engineering Lab	-	-	2	30	20	50	1

## [SELF ASSESSMENT REPORT]



10	ESC	1FY3-29/1FY3-28	Computer Aided Machine Drawing/ Computer Aided Engineering Graphics	-	-	3	45	30	75	1.5
11	SODECA	1FY8-00							25	0.5
<b>Total</b>									<b>1025</b>	<b>20.5</b>
<b>L = Lecture, T = Tutorial,</b> <b>P = Practical, IA = Internal Assessment,</b> <b>ETE = End Term Exam, Cr = Credits</b>										

<b>Teaching &amp; Examination Scheme</b>										
<b>II Year-III Semester, B.Tech.: Mechanical Engineering</b>										
SN	Category	Course Code	Course Title	Hours			Marks			Cr
				L	T	P	IA	ETE	Total	
1	BSC	3ME2-01	Advance Engineering Mathematics-I	3	0	0	30	120	150	3
2	HSMC	3ME1-02/ 3ME1-03	Technical Communications/ Managerial Economics and Financial Accounting	2	0	0	20	80	100	2
3	ESC	3ME3-04	Engineering Mechanics	2	0	0	20	80	100	2
4	PCC	3ME4-05	Engineering Thermodynamics	3	0	0	30	120	150	3
5	PCC	3ME4-06	Materials Science and Engineering	3	0	0	30	120	150	3
6	PCC	3ME4-07	Mechanics of Solids	3	1	0	40	160	200	4
7	PCC	3ME4-21	Machine Drawing Practice	0	0	3	45	30	75	1.5
8	PCC	3ME4-22	Materials Testing Lab	0	0	3	45	30	75	1.5
9	PCC	3ME4-23	Basic Mechanical Engineering Lab	0	0	3	45	30	75	1.5
10	PCC	3ME4-24	Programming using MAT Lab	0	0	3	45	30	75	1.5
11	Training Exam	3ME7-30							50	1
12	SODECA	3ME8-00							25	0.5
<b>Total</b>									<b>1225</b>	<b>24.5</b>
<b>L = Lecture, T = Tutorial, P = Practical,</b> <b>IA = Internal Assessment, ETE = End Term Exam, Cr = Credits</b>										



# [SELF ASSESSMENT REPORT]



Teaching & Examination Scheme										
II Year-IV Semester, B.Tech.: Mechanical Engineering										
SN	Category	Course Code	Course Title	Hours			Marks			Cr
				L	T	P	IA	ETE	Total	
1	BSC	4ME2-01	Data Analytics	2	0	0	20	80	<b>100</b>	<b>2</b>
2	HSMC	4ME1-03/ 4ME1-02	Managerial Economics and Financial Accounting/ Technical Communications	2	0	0	20	80	<b>100</b>	<b>2</b>
3	ESC	4ME3-04	Digital Electronics	2	0	0	20	80	<b>100</b>	<b>2</b>
4	PCC	4ME4-05	Fluid Mechanics and Fluid Machines	3	1	0	40	160	<b>200</b>	<b>4</b>
5	PCC	4ME4-06	Manufacturing Processes	3	0	0	30	120	<b>150</b>	<b>3</b>
6	PCC	4ME4-07	Theory of Machines	3	1	0	40	160	<b>200</b>	<b>4</b>
7	ESC	4ME4-21	Digital Electronics Lab	0	0	3	45	30	<b>75</b>	<b>1.5</b>
8	PCC	4ME4-22	Fluid Mechanics Lab	0	0	3	45	30	<b>75</b>	<b>1.5</b>
9	PCC	4ME4-23	Production Practice Lab	0	0	3	45	30	<b>75</b>	<b>1.5</b>
10	PCC	4ME4-24	Theory of Machines Lab	0	0	3	45	30	<b>75</b>	<b>1.5</b>
11	SODECA	4ME8-00							<b>25</b>	<b>0.5</b>
<b>Total</b>									<b>1175</b>	<b>23.5</b>

## Scheme of First Year

Scheme & Syllabus of Teaching & Examination for I year B. Tech. I Semester Effective from the session: 2017-18								
		Course Title	L	T	P	Marks		
S. N.	Subject Code					IA	External	Total
		<b>Theory Papers</b>						
1	MA-101	Engineering Mathematics-I	3	1	0	20	80	100
2	HU-101/ HU-103	Communication Skills/ Human Values	3	0	0	20	80	100
3	PY-101/ CY-101	Engineering Physics/ Engineering Chemistry	3	1	0	20	80	100
4	CS-101	Computer Programming-I	3	0	0	20	80	100

## [SELF ASSESSMENT REPORT]



5	CE-101	Environmental Engineering and Disaster Management	3	0	0	20	80	100
		Total	15	2	0	100	400	500
		<b>Practical</b>						
6	HU-102/ HU-104	Communication Skills Lab/ Human Values: Activities	0	0	2	45	30	75
7	PY-102/ CY-102	Engineering Physics Lab/ Engineering Chemistry Lab	0	0	2	45	30	75
8	CS-102	Computer Programming-I Lab	0	0	2	60	40	100
9	CE-102	Computer Aided Engineering Graphics	0	0	3	60	40	100
10	ME-101	Mechanical Workshop Practice	0	0	2	60	40	100
11		Discipline & Extra Curricular Activity	0	0	0	50	0	50
		Total	0	0	11	320	180	500
		<b>Grand Total</b>	<b>15</b>	<b>2</b>	<b>11</b>	<b>420</b>	<b>580</b>	<b>1000</b>

(Total **28** periods per week)

**L** = Lecture, **T** = Tutorial, **P** = Practical, **IA** = Internal Assessment

### Scheme & Syllabus of Teaching & Examination for I year B. Tech. II Semester Effective from the session: 2017-18

S. N.	Subject Code	Course Title	L	T	P	Marks		
						IA	External	Total
		<b>Theory Papers</b>						
1	MA-102	Engineering Mathematics-II	3	1	0	20	80	100
2	HU-103/ HU-101	Human Values/ Communication Skills	3	0	0	20	80	100
3	CY-101/ PY-101	Engineering Chemistry/ Engineering Physics	3	1	0	20	80	100
4	CS-103	Computer Programming-II	3	0	0	20	80	100
		<b>Elective (any two)*</b>						
5	EE-101	Basic Electrical and Electronics Engineering	3	0	0	20	80	100
6	CE-103	Basic Civil Engineering	3	0	0	20	80	100
7	ME-102	Basic Mechanical Engineering	3	0	0	20	80	100
8	OE-101	Engineering Mechanics	3	0	0	20	80	100
		Total	18	2	0	120	480	600
		<b>Practical</b>						

## [SELF ASSESSMENT REPORT]



9	HU-104/ HU-102	Human Values: Activities/ Communication Skills Lab	0	0	2	45	30	75
10	CY-102/ PY-102	Engineering Chemistry Lab/ Engineering Physics Lab	0	0	2	45	30	75
11	CS-104	Computer Programming-II Lab	0	0	2	60	40	100
12	ME-104	Computer Aided Machine Drawing	0	0	3	60	40	100
13		Discipline & Extra Curricular Activity	0	0	0	50	0	50
Total			0	0	9	260	140	400
<b>Grand Total</b>			<b>18</b>	<b>2</b>	<b>9</b>	<b>380</b>	<b>620</b>	<b>1000</b>

(Total **29** periods per week)

**L** = Lecture, **T** = Tutorial, **P** = Practical, **IA** = Internal Assessment

**\*Elective: The student of a particular branch will not be allowed to opt for his own branch subject.**

Scheme of Teaching & Examination for I year B. Tech. I Semester										
Effective from the Session: 2012 - 2013										
(Common to all branches of Engineering)										
Sub Code	Subject	Number of Teaching Hours per week			Duratio n of Theory Paper (Hours)	Marks Allocation				
		L	T	P		Theor y	Ter m Test	Sessio na l	Prac. Exa m	Tota l
101	Communicative English	3	1	-	3	80	20			100
102	Engineering Mathematics-I	3	1	-	3	80	20			100
103	Engineering Physics-I	3	1	-	3	80	20			100
104	Engineering Chemistry	3	1	-	3	80	20			100
105	Basic Electrical & Electronics Engineering	3	-	-	3	80	20			100
	<b>Total</b>	<b>15</b>	<b>04</b>	<b>-</b>	<b>-</b>	<b>400</b>	<b>100</b>			<b>500</b>
106	Engineering Physics Lab-I	-	-	2				45	30	75
107	Engineering Chemistry Lab	-	-	2				45	30	75

## [SELF ASSESSMENT REPORT]



108	Electrical & Electronics Lab	-	-	2				60	40	100
109	Practical Geometry	-	-	3				60	40	100
110	Workshop Practice	-	-	2				60	40	100
111	Discipline & Extra Curricular Activities	-	-	-				50	-	50
<b>Grand Total</b>		<b>15</b>	<b>04</b>	<b>11</b>	<b>-</b>	<b>400</b>	<b>100</b>	<b>320</b>	<b>180</b>	<b>1000</b>
(Total 30 periods per week)										

<b>Scheme of Teaching &amp; Examination for I year B. Tech. II Semester</b>										
<b>Effective from the Session: 2012 - 2013</b>										
<b>(Common to all branches of Engineering)</b>										
Sub Code	Subject	Number of Teaching Hours per week			Duration of Theory Paper (Hours)	Marks Allocation				
		L	T	P		Theory	Term Test	Sessional	Prac. Exam	Total
201	Communication Techniques	2	-	-	3	80	20			100
202	Engineering Mathematics-II	3	1	-	3	80	20			100
203	Engineering Physics-II	2	1	-	3	80	20			100
204	Chemistry & Environmental Engineering	3	1	-	3	80	20			100
205	Engineering Mechanics	3	1		3	80	20			100
206	Fundamentals of Computer Programming	3	-	-	3	80	20			100
	<b>Total</b>	<b>16</b>	<b>04</b>	<b>-</b>	<b>-</b>	<b>480</b>	<b>120</b>			<b>600</b>
207	Engineering Physics Lab-II	-	-	2				30	20	50
208	Chemistry & Environmental Engineering Lab	-	-	2				30	20	50
209	Computer Programming Lab	-	-	2				45	30	75

## [SELF ASSESSMENT REPORT]



210	Machine Drawing	-	-	3				60	40	100
211	Communication Technique Lab	-	-	2				45	30	75
212	Discipline & Extra Curricular Activities	-	-	-				50	-	50
<b>Grand Total</b>		<b>16</b>	<b>04</b>	<b>11</b>	<b>-</b>	<b>480</b>	<b>120</b>	<b>260</b>	<b>140</b>	<b>1000</b>
(Total 31 periods per week)										
L = Lecture, T = Tutorial, P = Practical										

### Scheme of Mechanical Engineering

Rajasthan Technical University, Kota											
B. Tech. (Mechanical Engineering Scheme)											
Course	BOS Mechanical								Code	ME	
SEMESTER III	3				3	Contact Hrs./Week			IA	Exam	Total
Subject Code	Title				L	T	P				
3ME1A	Mechanics of Solids-I				3	1	Theory Subjects	20	80	100	
3ME2A	Material Science and Engineering				3			20	80	100	
3ME3A	Engineering Thermodynamics				3	1		20	80	100	
3ME4A	Manufacturing Processes				3			20	80	100	
3ME5A	Object Oriented Programming in C++				2			20	80	100	
3ME6A	Advanced Engineering Mathematics				3	1		20	80	100	
	Practicals and Sessionals										
3ME7A	Material Science and Testing Lab				Lab Courses		2	45	30	75	
3ME8A	Basic Mechanical Engineering Lab						2	45	30	75	
3ME9A	Production Practice - I						3	45	30	75	
3ME10A	Computer Programming Lab						2	30	20	50	
3ME11A	Mechanical Engineering Drawing						3	45	30	75	
3MEDC	Discipline & Extra Curricular Activity									50	
	Total				17	3	12			1000	
SEMESTER IV	4				4	Contact Hrs./Week			IA	Exam	Total
Subject Code	Title				L	T	P				
4ME1A	Kinematics of Machines				3	1	ry Su bj	20	80	100	

## [SELF ASSESSMENT REPORT]



4ME2A	Fluid Mechanics & Machines		3	1		20	80	100	
4ME3A	Machining & Machine Tools		3			20	80	100	
4ME4A	Design of Machine Elements - I		3			20	80	100	
4ME5A	Industrial Design		3			20	80	100	
4ME6A	I.C. Engines		3			20	80	100	
	Practicals and Sessionals								
4ME7A	Kinematics of Machines Lab		Lab Courses			2	45	30	75
4ME8A	Fluid Mechanics Lab					2	30	20	50
4ME9A	Production Practice-II					3	45	30	75
4ME10A	Machine Design Sessional-I					3	45	30	75
4ME11A	Thermal Engineering Lab-I					2	45	30	75
4MEDC	Discipline & Extra Curricular Activity							50	
	Total		18	2	12			1000	

Rajasthan Technical University, Kota  
B. Tech. (Mechanical Engineering Scheme)

SEMESTER V	5	5	Contact Hrs./Week			IA	Exam	Total
Subject Code	Title	L	T	P				
5ME1A	Heat Transfer	3	1	Theory Subjects	20	80	100	
5ME2A	Dynamics of Machines	3	1		20	80	100	
5ME3A	Measurement & Metrology	3			20	80	100	
5ME4A	Quality Assurance and Reliability	3			20	80	100	
5ME5A	Sociology and Economics for Engineers	3			20	80	100	
5ME6.1A	Computer Aided Design and Graphics	3				20	80	100
5ME6.2A	Automobile Engg.							
5ME6.3A	Statistics for Decision Making							
	Practicals and Sessionals							
5ME7A	Heat Transfer Lab	Lab Courses			3	75	50	125
5ME8A	Dynamics of Machines Lab				2	45	30	75
5ME9A	Production Engineering Lab				3	60	40	100
5ME10A	Professional Ethics and Disaster Management				2	30	20	50
5MEDC	Discipline & Extra Curricular Activity						50	
	Total	18	2	10			1000	
SEMESTER VI	6	6	Contact Hrs./Week			IA	Exam	Total
Subject Code	Title	L	T	P				
6ME1A	Design of Machine Elements -	3		ory Subject	20	80	100	

## [SELF ASSESSMENT REPORT]



	II							
6ME2A	Newer Machining Methods		3			20	80	100
6ME3A	Mechatronics		3			20	80	100
6ME4A	Vibration Engineering		3	1		20	80	100
6ME5A	Steam Engineering		3	1		20	80	100
6ME6.1A	Non Destructive Evaluation and Testing		3			20	80	100
6ME6.2A	Design and Manufacture of Plastic Products							
6ME6.3A	Maintenance Management							
	Practicals and Sessionals							
6ME7A	Machine Design Sessional-II		Lab Courses		3	75	50	125
6ME8A	Industrial Engineering Lab-I				2	45	30	75
6ME9A	Mechatronics Lab				2	45	30	75
6ME10A	Vibration Engineering Lab				2	45	30	75
6MEDC	Discipline & Extra Curricular Activity							50
	Total		18	2	9			1000

Rajasthan Technical University, Kota

B. Tech. (Mechanical Engineering Scheme)

SEMESTER VII	7	7	Contact Hrs./Week			IA	Exam	Total
Subject Code	Title		L	T	P			
7ME1A	Finite Element Methods		3		Theory Subjects	20	80	100
7ME2A	Refrigeration & Air-Conditioning		3	1		20	80	100
7ME3A	Operations Research		3	1		20	80	100
7ME4A	Turbomachines		3			20	80	100
7ME5A	Operations Management		3			20	80	100
7ME6.1A	Micro and Nano Manufacturing		3				20	80
7ME6.2A	Robotics							
7ME6.3A	CNC Machines and Programming							
	Practicals and Sessionals							
7ME7A	Thermal Engineering Lab-II		Lab Courses		3	60	40	100
7ME8A	FEM Lab				3	60	40	100
7METR	Practical Training & Industrial Visit				2		100	100
7MEPR	Project-I				2	50		50
7MEDC	Discipline & Extra Curricular Activity							50
	Total		18	2	10			1000

## [SELF ASSESSMENT REPORT]



SEMESTER VIII	8	8	Contact Hrs./Week			IA	Exam	Total
Subject Code	Title	L	T	P				
8ME1A	Computer Integrated Manufacturing Systems	3		Theory Subjects	20	80	100	
8ME2A	Laws for Engineers	3			20	80	100	
8ME3A	Power Generation	3	1		20	80	100	
8ME4.1A	Product Development and Launching	3			20	80	100	
8ME4.2A	Computational Fluid Dynamics							
8ME4.3A	Total Quality Management							
	Practicals and Sessionals							
8ME5A	CAM Lab	Lab Courses		2	45	30	75	
8ME6A	CAD Lab		3	60	40	100		
8ME7A	Industrial Engineering Lab-II		2	45	30	75		
8MEPR	Project-2		4	120	80	200		
8MESM	Seminar		2	60	40	100		
8MEDC	Discipline & Extra Curricular Activity						50	
	Total	12	1	13			1000	

For the complete syllabus of mechanical engineering branch, the link is given below

[http://www.rtu.ac.in/RTU/wp-content/uploads/2015/05/BTech-Mech-Syllabus12\\_13.pdf](http://www.rtu.ac.in/RTU/wp-content/uploads/2015/05/BTech-Mech-Syllabus12_13.pdf)

### Mapping of Programme Curriculum with POs

Course components				Mapping with POs
Basic Science (All 1 <sup>st</sup> year Subjects plus Mathematics)				PO1, PO2, PO3, PO4, PO5, PO6, PO7, PO9, PO10, PO11, PO12
CORE(Mechanical Engineering) (MOS, MSE, ET, MPS, KOM, FM, M&M, QAR, MMT, IE, DME, ICE, HT, DOM, NMM, VE, SE, FEM, RAC, TM, MNM, PG)				PO1, PO2, PO3, PO4, PO5, PO6, PO7, PO8, PO9, PO10, PO11, PO12, PSO1, PSO2
ELECTIVE(Mechanical Engineering) (AE, MM, MNM, PDL)				
S#	NAME OF SUBJECTS	SUB CODE	PO'S	
1	Computer Integrated Manufacturing Systems	8ME1A	PO1,PO3,PO4.PO5,PO10,PO11	
2	Laws for Engineers	8ME2A	PO6,PO7,PO8	
3	Power Generation	8ME3A	PO1,PO2,PO3,PO4.PO5,PO6,PO7, PO8,PO9,PO10,PO11,PO12	



## [SELF ASSESSMENT REPORT]



4	Product Development and Launching	8ME4.1A	PO1,PO2,PO3,PO4
5	CAM Lab	8ME5A	PO1,PO2,PO3,PO10,PO12
6	CAD Lab	8ME6A	PO1,PO2,PO3,PO5
7	IE Lab	8ME7A	PO1,PO2,PO3,PO4,PO5,PO6,PO8, PO9,PO11,PO12
8	Project-2	8MEPR	PO1,PO2,PO3,PO5,PO7,PO8, PO9, PO10,PO11,PO12
9	Seminar	8MESM	PO1,PO2,PO5,PO6,PO7,PO8,PO9, PO10,PO12
10	Finite Element Methods	7ME1A	PO1,PO2,PO3,PO4, PO5,PO10
11	Refrigeration And Air Conditioning	7ME2A	PO1,PO2,PO3,PO4, PO6,PO7,PO11,PO12
12	Operations Research	7ME3A	PO1,PO2,PO3,PO4,PO5,PO9,PO10, PO11,PO12
13	Turbomachines	7ME4A	PO1,PO2,PO3,PO4,PO7
14	Operations Management	7ME5A	PO1,PO2,PO3,PO5,PO6,PO7,PO8, PO10,PO11,PO12
15	Micro and Nano Manufacturing	7ME6.1A	PO1,PO2,PO3,PO4,PO5,PO6,PO7, PO8,PO9,PO11,PO12
16	Thermal Engineering Lab-II	7ME7A	PO1,PO2,PO3,PO4,PO7,PO9,
17	Finite Element Lab.	7ME8A	PO1,PO2,PO3,PO4,PO5
18	Practical Training & Industrial Visit	7METR	PO1,PO2,PO5,PO6,PO7,PO8,PO9, PO10,PO12
19	Project-1	7MEPR	PO1,PO2,PO3,PO5,PO7,PO8,PO9, PO10,PO11,PO12
20	Design of Machine Elements - II	6ME1A	PO1,PO2,PO3,PO4,PO10,PO11
21	Newer Machining Methods	6ME2A	PO1,PO2,PO3,PO5,PO6,PO7,PO12
22	Mechatronics	6ME3A	PO1,PO2,PO3,PO4,PO5,PO6,PO7, PO9,PO10,PO11,PO12
23	Vibration Engineering	6ME4A	PO1,PO2,PO3,PO5,PO6,PO7, PO10,PO12
24	Steam Engineering	6ME5A	PO1,PO2,PO3,PO7,PO12
25	Maintenance Management	6ME6.3A	PO1,PO3,PO5,PO6,PO7,PO9,PO11,PO12
26	Machine Design Sessional-II	6ME7A	PO1,PO2,PO3,PO4,PO10,PO11
27	Industrial Engineering Lab-I	6ME8A	PO1,PO2,PO3,PO4,PO5,PO6,PO7, PO9,PO10,PO11,PO12
28	Mechatronics Lab	6ME9A	PO1,PO2,PO3,PO4,PO5,PO6,PO7, PO9,PO10,PO11,PO12
29	Vibration Engineering Lab	6ME10A	PO1,PO2,PO5,PO6,PO7, PO9,PO11
30	Heat Transfer	5ME1A	PO1,PO2,PO7,PO12
31	Dynamics Of Machines	5ME2A	PO1,PO2,PO3
32	Measurement & Metrology	5ME3A	PO1,PO2,PO5,PO7,PO8,PO9, PO10,PO12
33	Quality Assurance And Reliability	5ME4A	PO1,PO2,PO4,PO9,PO11
34	Sociology And Elements Of Economics For Engineers	5ME5A	PO1,PO6,PO7,PO8,PO9,PO10, PO11,PO12
35	Automobile Engineering	5ME6.2A	PO1,PO2,PO3,PO5,PO6,PO8, PO10,PO11,PO12
36	Heat Transfer Lab	5ME7A	PO1,PO7,PO9,PO12
37	Dynamics of Machines Lab. – II	5ME8A	PO1,PO2,PO3,PO12

## [SELF ASSESSMENT REPORT]



38	Production Engineering Lab	5ME9A	PO1,PO2,PO3,PO5,PO6,PO9,PO12
39	Professional Ethics And Disaster Management	5ME10A	PO1,PO6,PO7,PO8,PO9,PO10,PO12
40	Kinematics of Machines	4ME1A	PO1,PO2,PO3,PO4
41	Fluid Mechanics & Machines	4ME2A	PO1,PO2,PO3,PO6
42	Machining & Machine Tools	4ME3A	PO1,PO2,PO3,PO4,PO5,PO6,PO10
43	Design of Machine Elements - I	4ME4A	PO1,PO2,PO3,PO5,PO7, PO10,PO11
44	Industrial Engineering	4ME5A	PO1,PO2,PO3,PO4,PO5,PO6,PO7, PO8,PO9,PO10,PO11,PO12
45	I.C. Engines	4ME6A.2 A	PO1,PO2,PO3,PO4,PO5,PO6,PO7, PO10,PO11
46	Kinematics of Machine Lab	4ME7A	PO1,PO2,PO9,PO12
47	Fluid Mechanics Lab	4ME8A	PO1,PO2,PO7,PO9
48	Production Practice-II	4ME9A	PO1,PO2,PO3,PO9,PO12
49	Machine Design Sessional - I	4ME10A	PO1,PO2,PO5,PO7,PO10,PO11
50	Thermal Engineering Lab-I	4ME11A	PO1,PO2,PO3,PO4,PO6,PO7, PO9,PO11,PO12
51	Mechanics of Solids	3ME1A	PO1,PO2,PO12
52	Material Science and Engineering	3ME2A	PO1,PO2,PO12
53	Engineering Thermodynamics	3ME3A	PO1,PO2,PO3,PO4,PO6,PO7, PO11,PO12
54	Manufacturing Processes	3ME4A	PO1,PO2,PO3,PO4,PO6,PO9,
55	Object Oriented Programming in C ++	3ME5A	PO1,PO2,PO3,PO4,PO5,PO9, PO10,PO11,PO12
56	Advanced Engineering Mathematics	3ME6A	PO1,PO2,PO3,PO4,PO5,PO6,PO7, PO9,PO10,PO12
57	Material Science And Testing Lab	3ME7A	PO1,PO3,PO9
58	Basic Mechanical Engineering Lab	3ME8A	PO1,PO2,PO9
59	Production Practice-I	3ME9A	PO1,PO2,PO3,PO5,PO7
60	Computer Programming Lab	3ME10A	PO1,PO2,PO3,PO4,PO5,PO9, PO10,PO11,PO12
61	Mechanical Engineering Drawing	3ME11A	PO1,PO3,PO9,PO10,PO11,PO12
62	Basic Mechanical Engineering	ME-102	PO1, PO12
63	Engineering Mechanics	OE-101	PO1,PO2,PO12
64	Computer Aided Machine Drawing	ME-104	PO1,PO2,PO3,PO5,PO6,PO7, PO10,PO12
65	Computer Aided Engineering Graphics	CE-102	PO1,PO5,PO10,PO12
66	Mechanical Workshop practice	ME-101	PO1,PO2,PO3,PO4,PO6,PO7,PO9, PO10,PO11,PO12



### Contribution of Subjects for Attaining POs

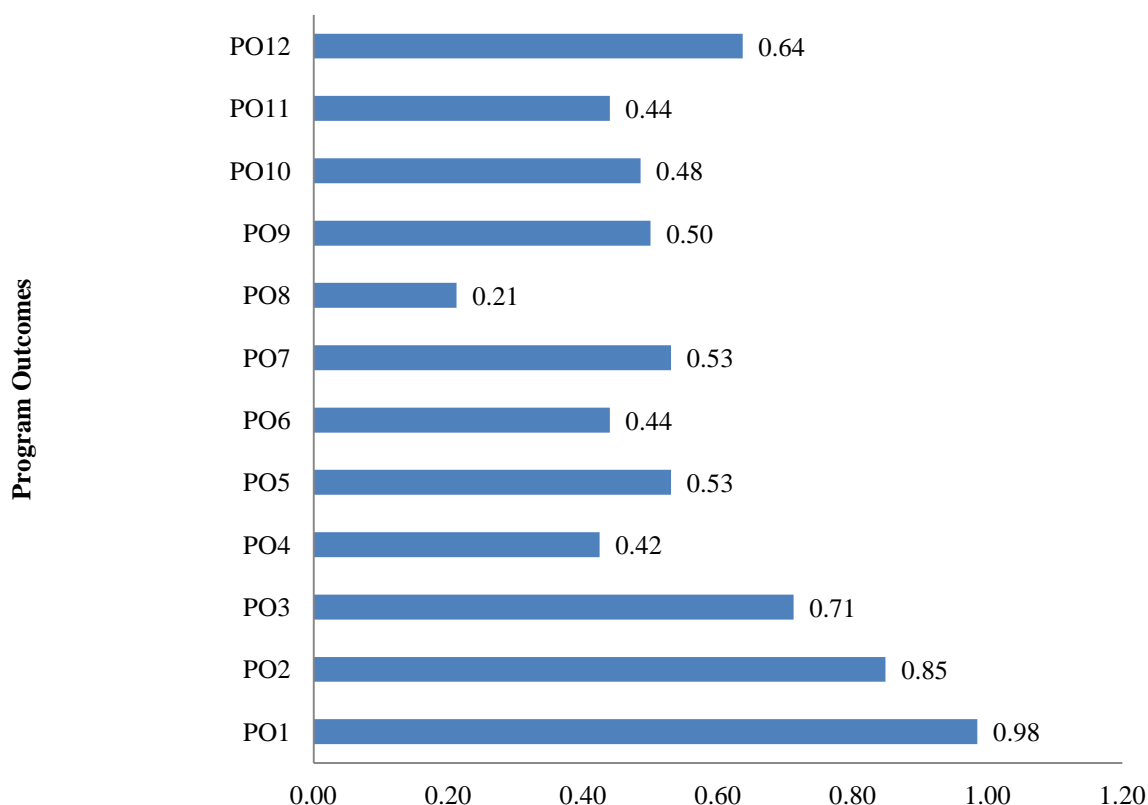

	PO1	PO2	PO3	PO4	PO5	PO6	PO7	PO8	PO9	PO10	PO11	PO12
Contribution of Subjects for Attaining Pos	0.98	0.85	0.71	0.42	0.53	0.44	0.53	0.21	0.50	0.48	0.44	0.64

Contribution of Subjects

**2.1.1 State the process used to identify extent of compliance of the University curriculum for attaining the Program Outcomes and Program Specific Outcomes as mentioned in Annexure I. Also mention the identified curricular gaps, if any (10)**

#### Program Outcomes

- 1. Engineering knowledge:** Apply the knowledge of mathematics, science, engineering fundamentals, and an engineering specialization to the solution of complex engineering problems in Mechanical Engineering.
- 2. Problem analysis:** Identify, formulate, research literature, and analyze complex Mechanical Engineering problems reaching substantiated conclusions using first principles of mathematics, natural sciences, and engineering sciences.
- 3. Design/development of solutions:** Design solutions for complex Mechanical Engineering problems and design system components or processes that meet the specified needs with appropriate consideration for the public health and safety, and the cultural, societal, and environmental considerations.



4. **Conduct investigations of complex problems:** Use research-based knowledge and research methods including design of experiments, analysis and interpretation of data, and synthesis of the information to provide valid conclusions in Mechanical Engineering.
5. **Modern tool usage:** Create, select, and apply appropriate techniques, resources, and modern engineering and IT tools including prediction and modeling to complex Mechanical Engineering activities with an understanding of the limitations.
6. **The engineer and society:** Apply reasoning informed by the contextual knowledge to assess societal, health, safety, legal and cultural issues and the consequent responsibilities relevant to the professional Mechanical Engineering practice.
7. **Environment and sustainability:** Understand the impact of the professional Mechanical Engineering solutions in societal and environmental contexts, and demonstrate the knowledge of, and need for sustainable development.
8. **Ethics:** Apply ethical principles and commit to professional ethics and responsibilities and norms of the Mechanical Engineering practice.
9. **Individual and team work:** Function effectively as an individual, and as a member or leader in diverse teams, and in multidisciplinary settings in Mechanical Engineering.
10. **Communication:** Communicate effectively on complex Mechanical Engineering activities with the engineering community and with society at large, such as, being able to comprehend and write effective reports and design documentation, make effective presentations, and give and receive clear instructions.
11. **Project management and finance:** Demonstrate knowledge and understanding of the Mechanical Engineering and management principles and apply these to one's own work, as a member and leader in a team, to manage projects and in multidisciplinary environments.
12. **Life-long learning:** Recognize the need for, and have the preparation and ability to engage in independent and life-long learning in the broadest context of technological change in Mechanical Engineering.

### PSO-Program Specific outcomes

1. **PSO1.** Apply the knowledge of material science, manufacturing and design to implement the various concepts of vehicle mechanics.
2. **PSO2.** Apply the knowledge of 3D printing technology in design and development of prototypes.

The current pace of industry's changes mean that some curriculum is not according to the current demand of industries. Besides the domain skills, the industry also looks soft skills, team building, values and attitude of an individual at the time of hiring. So it is required to identify the extent of compliance of University curriculum.

Following is the process used to identify extent of compliance of University curriculum for attaining the POs and PSOs.

- Feedback from the teacher handling the course.
- Input from Industry experts/ employers.
- Based on the feedback from placement cell.
- Based on alumni feedback.
- On the basis of CO attainment of individual courses.
- On the basis of POs and PSOs attainment.

The procedure adopted for finding the curriculum gaps is shown in figure 2.1 while figure 2.2 indicates the process adopted for the identification and modification of curricular gaps for the attainment of the COs/POs.

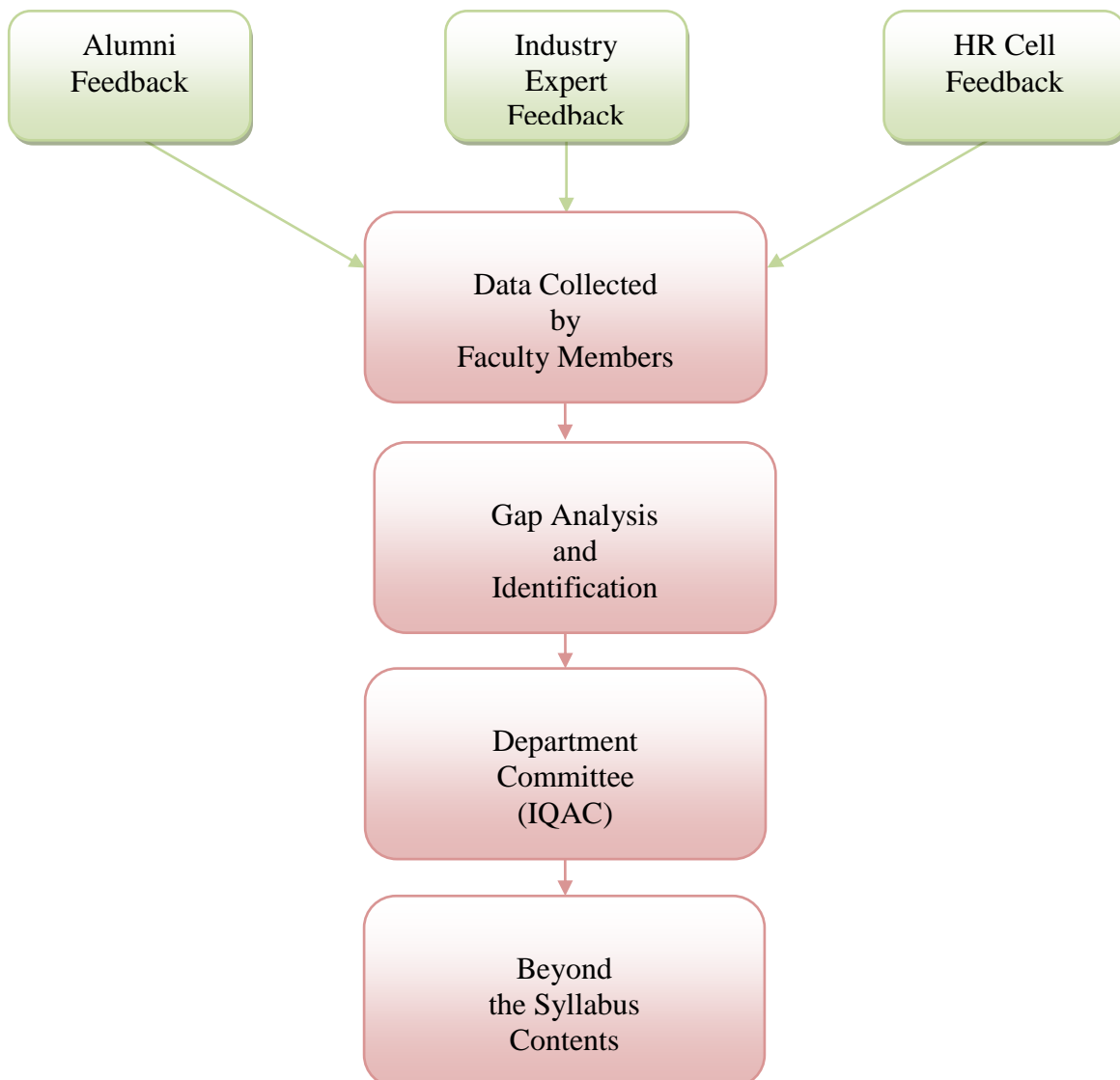

**Figure 2.1 Curriculum gap analyses**

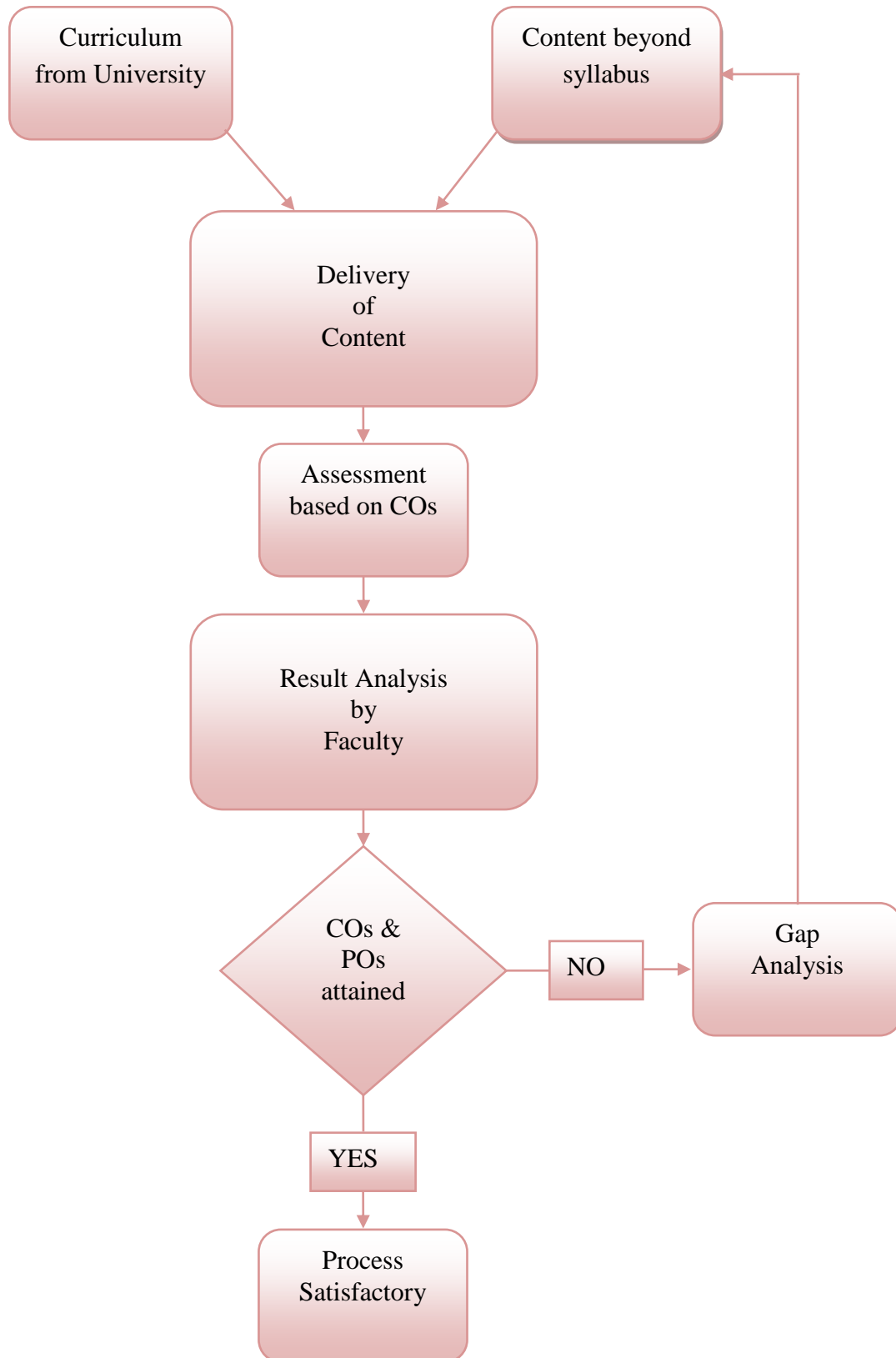

**Figure 2.2 Processes for the identification and modification of curricular gaps for the attainment of the COs/Pos**

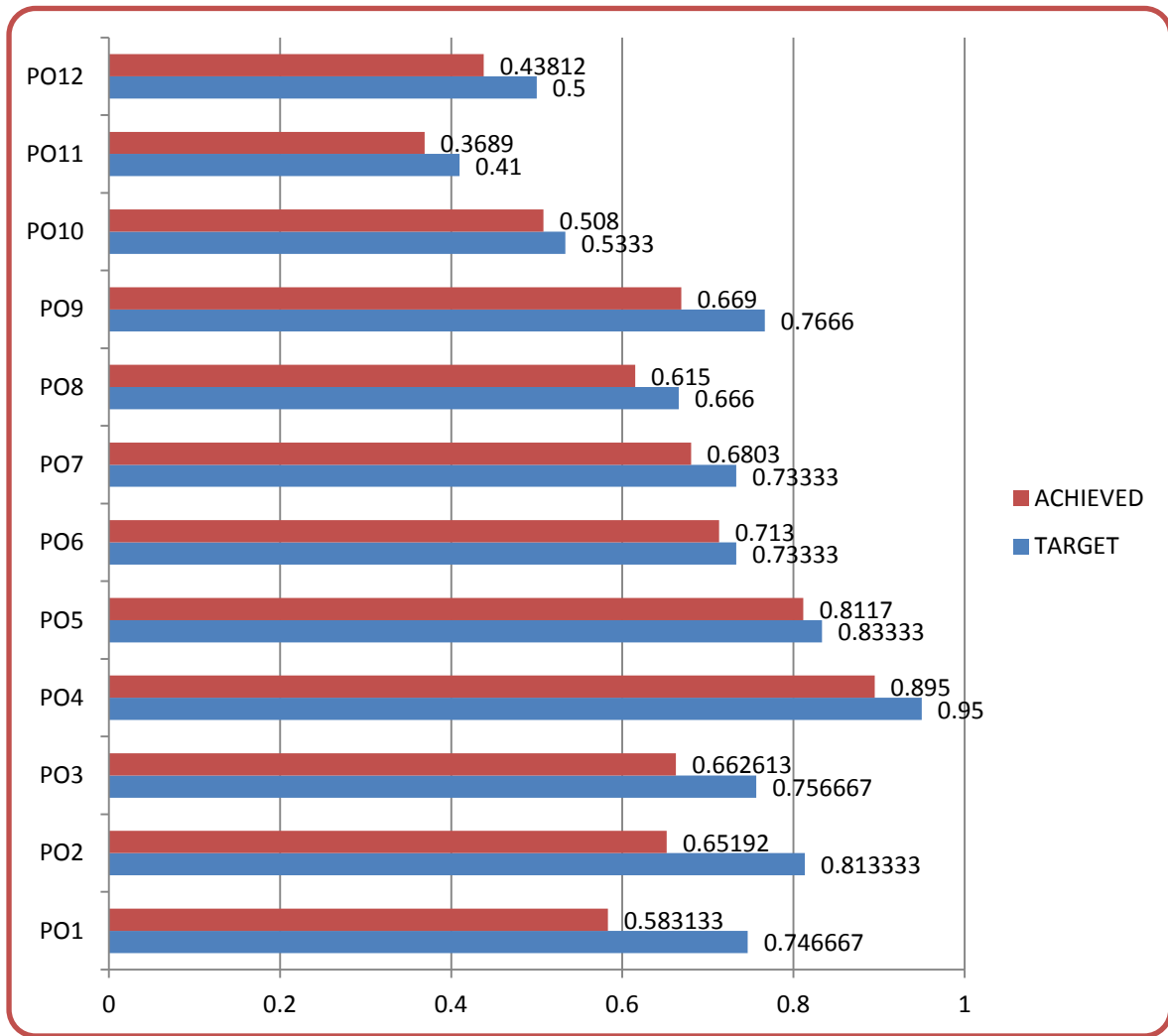

Figure 2.3 POs Attainment [Session 2017-18]

# [SELF ASSESSMENT REPORT]



## List of Curricular Gaps CAY - 2017-18

S#	Course Name	Gap Description	Relevance with POs	Proposed Action
1	CAM Lab	Advance CNC programming for cutter/nose radius compensation	PO1,PO2,PO3,PO4,PO5,PO12	Industrial Visit
2	Automobile Engineering	Different aspects during designing of ATV	PO1,PO2,PO3,PO4,PO5,PO9,PO12, <b>PSO1</b>	Workshop
3	Strength of Materials	Stress analysis in fixed beam	PO1,PO2,PO3,PO4,PO5,PO6,PO12	Guest lecture
4	Communication and Placement Training	Aptitude, Reasoning, Quantitative/ group discussion/ HR Training	PO8, PO9, PO10,PO12	Training
5	Professional Ethics and Disaster Management	Disaster Management	PO1, PO6, PO7,PO12	Industrial Visit
6	Computer Integrated Manufacturing Systems	3-D Printing	PO1,PO2,PO3PO4,PO5, PO12,PSO2	Workshop
7	Sociology and economics for engineers	Social events	PO6, PO7,PO8, PO9,PO10,PO11,PO12	Social activity through Abhudhya
8	Design of Machine Elements	Design consideration during design of roller bearing and testing of different types of bearing	PO1, PO2, PO3, PO5, PO6, PO12,PSO2	Guest lecture
9	Quality Assurance and Reliability	Advance quality improvement tools	PO1, PO2, PO5, PO6, PO8, PO12	Guest lecture
10	Micro and Nano Manufacturing	Advance welding technology	PO1, PO2, PO3, PO4	Guest lecture
11	Operation Management	Application of ERP in industry	PO5,PO11	Guest lecture
12	Finite Elements Method	Buckling analysis of mechanical components subjected to different type of loads	PO1,PO2,PO3,PO4,PO5,PO12,PSO2	Workshop
13	CAD	Advance drafting tool	PO5,PO10,PO12,PSO2	Workshop
14	Machining & Machine Tools	Working of advance machine tools	PO1,PO2,PO3,PO4,PO5,PO12	Industrial visit
15	Computer Integrated Manufacturing System	Basic introduction of Inventor/Master CAM	PO1,PO3,PO6,PO12,PSO2	Guest Lecture/workshop



# [SELF ASSESSMENT REPORT]

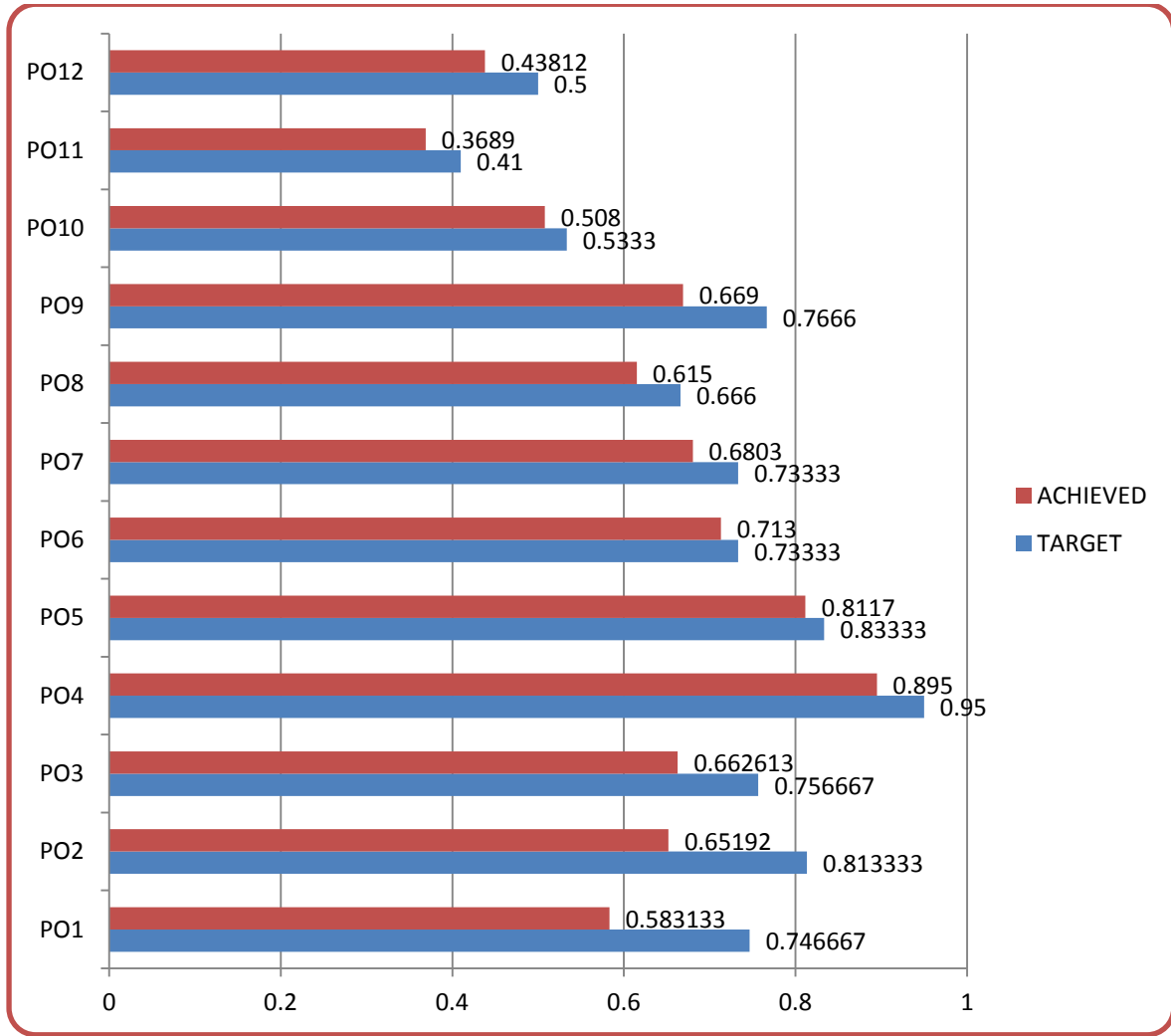

Figure 2.4 POs Attainment [Session 2016-17]

# [SELF ASSESSMENT REPORT]



## List of Curricular Gaps CAYm1 - 2016-17

S#	Course Name	Gap Description	Relevance with POs	Proposed Action
1	I.C. Engines	Working of Six stroke engine	PO1,PO2,PO3, PO4,PO5,PO12	Guest lecture
2	CAM Lab	Advance CNC programming for cutter/nose radius compensation	PO1,PO2, PO4,PO5,PO12	Industrial Visit
3	Automobile Engineering	Different aspects during designing of ATV	PO1,PO2,PO3, PO4,PO5,PO9, PO12,PSO1	Workshop
4	Strength of Materials	Stress analysis in fixed beam	PO1,PO2,PO3, PO4,PO5,PO6, PO12	Guest lecture
5	Communication and Placement Training	Aptitude, Reasoning, Quantitative/ group discussion/ HR Training	PO8, PO9,PO10,PO12	Training
6	Professional Ethics and Disaster Management	Waste Management in hospital	PO1, PO6,PO7,PO12	Industrial Visit
7	Computer Integrated Manufacturing Systems	3-D Printing	PO1,PO2,PO3, PO4,PO5, PO12,PSO2	Workshop
8	Sociology and economics for engineers	Social events	PO6, PO7,PO8,PO9, PO10,PO11,PO12	Social activity through "Abhudhya"
9	Design of Machine Elements-1 & Design of Machine Elements-2	Design consideration during design of roller bearing and testing of different types of bearing	PO1, PO2, PO3, PO5, PO6, PO12,PSO2	Guest lecture
10	Quality Assurance and Reliability	Advance quality improvement tools	PO1, PO2, PO5, PO6, PO8, PO12	Guest lecture
11	Material science	Introduction of nano tubes and nano particles	PO1, PO2, PO3, PO4	Guest lecture
12	Micro and Nano Manufacturing	Advance welding technology	PO1, PO2, PO3, PO4	Guest lecture
13	Operation Management	Application of ERP in industry	PO5,PO11	Guest lecture
14	Finite Elements Method	Buckling analysis of mechanical components subjected to different type of loads	PO1,PO2,PO3, PO4,PO5,PO12 ,PSO2	Workshop
15	CAD	Advance drafting tool	PO5,PO10,PO12,PSO2	Workshop

# [SELF ASSESSMENT REPORT]

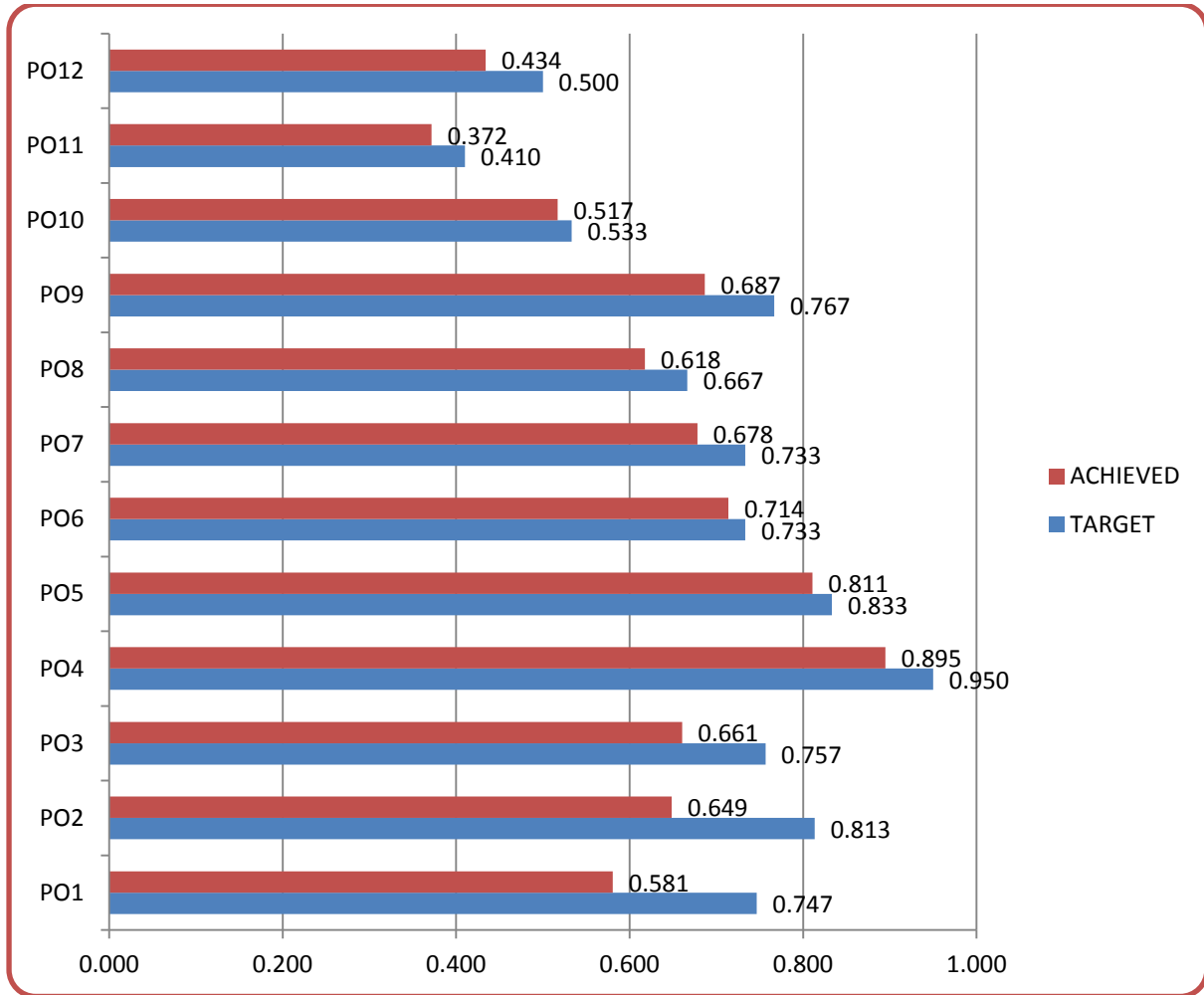

Figure 2.5 POs Attainment [Session 2015-16]

## [SELF ASSESSMENT REPORT]



### List of Curricular Gaps CAYm2 - 2015-16

S#	Course Name	Gap Description	Relevance with POs	Proposed Action
1	Machining & Machine Tools	Working of advance machine tools	PO1,PO2,PO3,PO4,PO5,PO12	Industrial Visit
2	Finite Elements Method	Buckling analysis of mechanical components subjected to different type of loads	PO1,PO2,PO3,PO4,PO5,PO12,PSO2	Workshop
3	Design of Machine Elements-1 & Design of Machine Elements-2	Design consideration during design of roller bearing and testing of different types of bearing	PO1, PO2, PO3, PO5, PO6, PO12,PSO2	Guest lecture
4	Quality Assurance and Reliability	Advance quality improvement tools	PO1, PO2, PO5, PO6, PO8, PO12	Guest lecture
5	Communication and Placement Training	Aptitude, Reasoning, Quantitative/ group discussion/ HR Training	PO8, PO9, PO10, PO12	Training
6	I.C. Engines	Working of Six stroke engine	PO1,PO2,PO3,PO4,PO5,PO12, PSO1	Guest lecture
7	Newer Machining Methods	Advancement in EDM	PO1, PO2, PO3, PO4, PO5, PO6, PO7, PO12	Guest Lecture
8	Engineering Thermodynamics	Application of Advanced Thermodynamics	PO1, PO2, PO3, PO6, PO7, PO12	Guest Lecture
9	Automobile Engineering	Different aspects during designing of ATV	PO1, PO2, PO3, PO4, PO5, PO9, PO12, PSO1	Workshop
10	Refrigeration & Air Conditioning	Air conditioning maintenance	PO1, PO3, PO4, PO5, PO6, PO7, PO12	Guest Lecture
11	CAD/CAM	Basic introduction of CREO	PO1, PO3, PO4, PO5, PO6, PO12, PSO2	Guest Lecture
12	CAD/CAM	Basic introduction of Inventor	PO1,PO3,PO6, PO12, PSO2	Guest Lecture
13	Sociology and economics for engineers	Social events	PO6, PO7,PO8,PO9,PO10,PO11,PO12	Social activity through <b>Abhudhya</b>

**2.1.2. State the delivery details of the content beyond the syllabus for the attainment of POs (10).**

The following are the means and methods used to accomplish the extent of compliance of the University curriculum for attaining the Program Outcomes are:



- Centre of Excellence
- 3D Printing Lab
- E -Books, GATE notes, GATE objectives questions (Govt. Job classes)
- Skill development activity (HR interview, communication skill classes, Moon rider club)
- Paper presentation/ participation in national/ international conferences
- Workshops ( automobile workshops, ANSYS, BAJA, 3 D printing)

## [SELF ASSESSMENT REPORT]



- Guest lectures
- Industrial visits
- Projects presentation
- Advance software training
- NPTEL videos /Swayam
- Social Activities

### Guest lecture/ Workshops/ Industrial visits (2017-18) to attained the POs

Guest lecture/ Workshops/ Industrial visits (2017-18)								
S #	Subject	Sem.	Gap/ content	Action Taken	Date	Resource	% of students presented	Relevance to POs
1	Aptitude, Reasoning, Quantitative / group discussion/ HR Training	VII	Aptitude/ group discussion/ HR training/ Reasoning, Quantitative	Training	17 Jul-17/2017	Face academy	>90%	PO8, PO9,PO10, PO12
2	Mechanics of Solids	III	Stress analysis in fixed beam	Guest Lecture	11-08-2017	Mr. Abhishek Kumar	50 Students	PO1,PO2,P O3,PO4,P O5, PO12
3	Automobile Engineering	V	Different aspects during designing of ATV	Guest Lecture	21 Aug,2017	Mr. Nimesh Baba	50 Students	PO1,PO2,P O3,PO5,P O12, ,PSO1
4	CAM	VII	Advance CNC programming for cutter/nose radius compensation	Industrial Visit	06-09-2017	Mr. Rakesh Bangha	30 Students	PO1,PO2,P O3,PO5,P O12,
5	Professional Ethics and Disaster Management	V	Waste Management in hospital	Industrial Visit	14th Sept. 2017	Mr. Santosh Bansal	30 Students	PO1, PO6,PO7,P O12
6	Computer Integrated Manufacturing Systems	VII	3-D Printing	Workshop	25-26 Oct. 2017	Mr. Promod Kumar	30 Students	PO1,PO2,P O3,PO4,P O5,PO12,
7	Automobile Engineering and I.C. Engines	IV	Working of Six stroke engine	Workshop	1 –2 Dec 2017	Mr. Nimesh Baba	30 Students	PO1,PO2,P O3,PO4,P O5,PO9,P O12

## [SELF ASSESSMENT REPORT]



8	Sociology and economics for engineers	ALL	Social events	Social activity		Abhudhya	ALL	PO6, PO7, PO8, PO9, PO10, PO11, PO12
9	CAD	IV and VI	Solid works	Training	8/3/2018 - 5/4/2018	Mr. Rakesh	38	PO1, PO2, PO3, PO4, PO5, PO12
10	CAD	IV and VI	Autocad	Training	31/1/2018 - 23/2/2018	Mr. Karan	32	PO5, PO10, PO12
11	Finite Elements Method	IV and VI	Buckling analysis of mechanical components subjected to different type of loads using ANSYS	Training	31/1/2018 - 23/2/2018	Mr. Kamlesh	25	PO1, PO2, PO3, PO4, PO5, PO12
12	Material science	III	Introduction of nano tubes and nano particles	Guest Lecture	6/4/2018	Dr. Alba Baena	>80%	PO1, PO2, PO3, PO4
13	Micro and Nano Manufacturing	VII	Advance welding technology	Guest Lecture	6/4/2018	Dr. Meghan shu Vashista	>80%	PO1, PO2, PO3, PO4
14	Operation Management	VII	Application of ERP in industry	Guest Lecture	7/4/2018	Dr. Ashok Sharma	>70%	PO5, PO11
15	Recent Innovations & Technological Development in Mechanical Engineering		Advance research in Mechanical engineering	Conference		Mechanical Department	All	PO1, PO2, PO3, PO4, PO5

*Table B.2.1.2a*

### Guest lecture/ Workshops/ Industrial visits (2016-17) to attained the POs

Guest lecture/ Workshops/ Industrial visits (2016-17)								
S #	Subject	Sem.	Gap/ content	Action Taken	Date	Resource	% of students presented	Relevance to POs
1	Aptitude, Reasoning, Quantitative/group discussion/ HR Training	VII	Aptitude/ group discussion/ HR training/ Reasoning, Quantitative	Training	July 20- August 14, 2016	Face academy	>90%	PO8, PO9, PO10, PO12

## [SELF ASSESSMENT REPORT]



2	I.C. Engines	IV	Working of Six stroke engine	Guest Lecture	01-10-2016	Mr. Nimesh Baba	>80%	PO1, PO2, PO3, PO6, PO7, PO12, <b>PSO1</b>
3	Newer Machining Methods	VII	Advanceme nt in EDM	Guest Lecture	07-10-2016	Dr. Anand Pandey	>80%	PO1, PO2, PO3, PO4, PO5, PO6, PO7, PO12
4	Engineerin g Thermody namics	III	Application of Advanced Thermodyna mics	Guest Lecture	17-10-2016	Mr. Pramod Vashistha	>80%	PO1, PO2, PO3, PO6, PO7, PO12
5	I.C. Engines and Automobile Engineerin g	IV/V	Different aspects during designing of ATV	Worksho p	15-19 Nove mber 2016	Mr. Nimesh Baba	>80%	PO1, PO2, PO3, PO4, PO5, PO6, PO7, PO12, <b>PSO1</b>
6	Refrigerati on & Air Conditioni ng	VII	Air conditioning maintenance	Guest Lecture	17-02-2017	Mr. Alok Bhargava	>80%	PO1, PO3, PO4, PO5, PO6, PO7, PO12
7	CAD/CA M	VIII	Basic introduction of CREO	Guest Lecture	08-03-2017	Mr. Praveen Jain	>80%	PO1, PO3, PO4, PO5, PO6, PO12, <b>PSO2</b>
8	CAD/CA M	VIII	Basic introduction of Inventor	Guest Lecture	09-03-2017	Mr. Gaurav Jalan	>80%	PO1,PO3,P O6,PO12, <b>PSO2</b>
9	Quality Assurance & Reliability	V	Advance quality improvemen t tools	Guest Lecture	10-03-2017	Mr. Amit Soni	>80%	PO1,PO2,P O5, PO6,PO8,P O12
10	Design of Machine Elements-1 & Design of Machine Elements-2	IV/V I	Design consideratio n during design of roller bearing and testing of different types of bearing	Guest Lecture	11-03-2017	Mr. Abhishek Singh	>80%	PO1,PO2,P O3,PO5,P O6,PO12, <b>PSO2</b>
11	Finite Element Method	VII	Buckling analysis of mechanical components subjected to different type of loads	Worksho p	05-07 March , 2017	Mr. Rajeev Bhargav	50 Students	PO1,PO2,P O3,PO4,P O5,PO12, <b>PSO2</b>



## [SELF ASSESSMENT REPORT]



1 2	Machining & Machine Tools	IV	Working of advance machine tools	Industrial Visit	15th Feb, 2017	Mr. Pradeep Ojha	30 Students	PO1,PO2,P O3,PO4,P O5,PO12
1 3	Sociology and economics for engineers	A L L	Social events	Social activity		Abhudhya	ALL	PO6, PO7,PO8,P O9,PO10,P O11,PO12
1 4	National Conference on Futuristic Engineering Trends in Mechanical Engineering		Advance research in Mechanical engineering	National Conference		Mechanical Department	All	PO1,PO2,P O3,PO4,P O5,PO12

**Table B.2.1.2b**

### Guest lecture/ Workshops/ Industrial visits (2015-16) to attained the POs

Guest lecture/ Workshops/ Industrial visits (2015-16)								
S#	Subject	Sem .	Gap/ content	Action Taken	Date	Resource	% of students presented	Relevance to POs
1	Aptitude, Reasoning, Quantitative /group discussion/ HR Training	VII	Aptitude/ group discussion/ HR training/ Reasoning, Quantitative	Training	18/7/2015-6/8/2015	Face academy	>90%	PO8, PO9, PO10, PO12
2	Machine Tools	IV	Working of advance machine tools	Industrial Visit (HMT)	17th Dec, 2015	Dr.Manish	42 Students	PO1,PO2,P O3,PO4,PO 5,PO12
3	Automobile	V& VII	ATV design and development	Workshop	08-22 Feb, 2016	Elite Techno Group	50 Students	PO1,PO2,P O3,PO4,PO 5,PO12, <b>PSO1</b>
4	Mechatronics	III	Automatic Teller Medicine Machine	Guest Lecture	29-10-2015	Mr. Siddharth Singh (Business Head-TechieNest)	>80%	PO1, PO3, PO4, PO5, PO6, PO7, PO12
5	I.C. Engines and Automobile Engineering	IV/ V	Practical Aspect of Automobile Engineering	Guest Lecture	9 march 2016	Mr. Nimesh Baba	>80%	PO1, PO2, PO3, PO4, PO5, PO6, PO7, PO12, <b>PSO1</b>

**Table B.2.1.2c**

**GUEST LECTURES:**



**Guest Lecture Topic:** Advancement of Engines

**Resource Person:** Mr. Nimesh Baba

**Date:** 01-10-2016



**Guest Lecture Topic:** Application of Advanced Thermodynamics

**Resource Person:** Mr. Pramod Vashistha

**Date:** 17-10-2016

**WORKSOPS:**



**Workshop Topic:** Assembling and Disassembling of 2 & 4 Stroke Engines

**Resource Person:** Mr. Nimesh Baba

**Date:** 15-19 November 2016



**Workshop Topic:** ANSYS Training

**Resource Person:** Mr. Rajeev Bhargav

**Date:** 05-07 March, 2017



**Workshop Topic:** Assembling & Disassembling of the automobiles

**Resource Person:** Mr. Nimesh Baba

**Date:** 01 - 02 Dec 2017

#### INDUSTRIAL VISITS:



**Industry:** CIPET, Jaipur

**Resource Person:** Mr. Rakesh Bangha

**Date:** 06-09-2017



**Industry:** MSME, Jaipur

**Resource Person:** Mr. Pradeep Ojha

**Date:** 15-02-2017



**Industry:** MSME, Jaipur

**Resource Person:** Mr. Pradeep Ojha

**Date:** 15-02-2017

**TRAINING:**



**Training:** AutoCAD

**Resource Person:** Mr. Karan

**Date:** 31 Jan 2018 to 23 Feb. 2018

**SOCIAL ACTIVITIES:**



**BLOOD DONATION DRIVE**

**[Ashayein-The Life Saviours]**

**Date:** 11<sup>th</sup> October 2017



**SAVE GIRL CHILD**

[Suhasini]

**Date:** 8<sup>th</sup> March 2018



**CELEBRATING INNOCENCE**

[Zarurat]

**Date:** 24<sup>th</sup> March 2018



**CLEANINESS DRIVE**

[SOCH]

**Date:** 11<sup>th</sup> April 2017

**3D printing activities (Session: 2017-18)**

S. No.	Organization	Name of resource person	No. of students attended	Topic	PO attained
1	Sky Labs	Mr. Pramod Kumar	20	Fabrication of machine component using 3D printing	PO1, PO2, PO3, PO4, PO5, <b>PSO2</b>
2	Mech-Tech Club	Mr. Satyendra Kumar, Mr. Ravi Jangid, Ananya Chhattri	All students of 7 <sup>th</sup> Sem	Fabrication of machine component using 3D printing	PO1, PO2, PO3, PO4, PO5, <b>PSO2</b>





**Workshop Topic:** 3D - Printing

**Resource Person:** Mr. Pramod Kumar

**Date:** 25-26 Oct. 2017

### Conferences Organized

S#	Name of conference	Date	Level of conference	Conference outcomes	Relevance to POs
1	NCFTME-2015	14-15 March 2015	National	Knowledge about the research, innovations and future scope in Mechanical Engineering.	PO1, PO4, PO10, <b>PSO1</b> , <b>PSO2</b>
2	RESSD-2016	07-08 October 2016	National	Knowledge about the recent innovations in Mechanical Engineering.	PO1, PO4, PO10, <b>PSO1</b> , <b>PSO2</b>
3	RITDME-18	06-07 April 2018	International	To Enhance knowledge about recent innovation and research in Mechanical Engineering.	PO1, PO4, PO10, <b>PSO1</b> , <b>PSO2</b>



National Conference “**Futuristic Trends In Mechanical Engineering**”, held at JECRC, Jaipur, during **14-15 March 2015**



National Conference “**Renewable Energy Sources and Sustainable Development: Opportunities and Challenges**”, held at JECRC, Jaipur, during **07-08 October 2016**



Interational Conference “Recent Innovations and Technological Development in Mechanical Engineering”, held at JECRC, Jaipur, during 06-07 April 2018

**Technical Events Organized (Session 2015-16)**

S. No.	Name of technical event	Level of event	Date	Outcomes	Relevance to POs
1	Embryo	National	18/02/2016	Student will be able to present paper and improve their communication skill.	PO1,PO4,P010, <b>PSO1, PSO2</b>
2	Mightly Throttle	National	18/02/2016	Student will be able to enhance their knowledge of design of racing car.	PO1,PO3,P05,PO9, <b>PSO1</b>
3	Propello	National	18/02/2016	Student will be able to know basic concept propulsion.	PO1,PO3,P09
4	Cut 2 Design	National	19/02/2016	Student will be able to apply concept of Engineering drawing.	PO1,PO3

## [SELF ASSESSMENT REPORT]



5	Fork Lifter	National	19/02/2016	Student will be able to build a crane model using wooden material suitable enough to place the given weights on a platform using only hydraulic mechanism.	PO1,PO3,P09, <b>PSO2</b>
6	Brain quest	National	19/02/2016	Student will be able to improve their technical and general knowledge.	PO1
7	R-Mech Olympiad	National	20/02/2016	Student will be able to improve their core technical subject's knowledge.	PO1
8	CADD mania	National	20/02/2016	Student will be able to improve their designing skill.	PO1,PO5, <b>PSO2</b>
9	Reverse Engineering	National	20/02/2016	Student will be able to enhance their knowledge of engine parts.	PO1,PO3,P09

### Technical Events Organized (Session 2016-17)

S #	Name of technical event	Level of event	Date	outcomes	Relevance to POs
1	Embryo	National	8/03/2017	Student will be able to present paper and improve their communication skill.	PO1,PO4,P010, <b>PSO1, PSO2</b>
2	Mightly Throttle	National	10/03/2017	Student will be able to enhance their knowledge of design of racing car.	PO1,PO3,P05,PO9, <b>PSO1</b>
3	Propello	National	11/03/2017	Student will be able to know basic concept propulsion.	PO1,PO3,P09,
4	IV Show	National	11/03/2017	Student will be able to learn about the recent innovations in mechanical Engineering.	PO1,PO2, PO3,PO10, PO12

## [SELF ASSESSMENT REPORT]



5	Fork Lifter	National	11/03/2017	Student will be able to build a crane model using wooden material suitable enough to place the given weights on a platform using only hydraulic mechanism.	PO1,PO3,PO9, <b>PSO1</b>
6	Brain quest	National	9/03/2017	Student will be able to improve their technical and general knowledge.	PO1
7	R-Mech Olympiad	National	10/03/2017	Student will be able to improve their core technical subject's knowledge.	PO1
8	CADD mania	National	8/03/2017	Student will be able to improve their designing skill.	PO1,PO5, <b>PSO2</b>
9	Reverse Engineering	National	9/03/2017	Student will be able to enhance their knowledge of engine parts.	PO1,PO3,PO9



Technical Event: **EMBRYO**

Description: **Paper Presentation**

Date: **8/03/2017**



Technical Event: **REVERSE ENGINEERING**

Description: **Assembling and Disassembling of Engine**

Date: **9/03/2017**



Technical Event: **MIGHTY THROTTLE**

Description: **RC Car Event**

Date: **10/03/2017**



Technical Event: **FORK LIFTER**

Description: **Hydraulic Crane Event**

Date: **11/03/2017**



Technical Event: **PROPELLO**

Description: **Hydraulic Rocket Event**

Date: **11/03/2017**



Technical Event: **R-MECH OLYMPIAD**

Description: **Technical Knowledge Event**

Date: **10/03/2017**



Technical Event: **BRAINQUEST**

Description: **Technical Knowledge Event**

Date: **9/03/2017**





Technical Event: **EMBRYO**

Description: **Paper Presentation**

Date: **8/03/2017**

**Technical Events Organized (Session 2017-18)**

S.No.	Name of technical event	Level of event	Date	Outcomes	Relevance to POs
1	Embryo	National	25 - 26 March 2018	Student will be able to present paper and improve their communication skill.	PO1,PO4,P O10, <b>PSO1</b> , <b>PSO2</b>
2	Mighty Throttle	National	26-03- 2018	Student will be able to enhance their knowledge of design of racing car.	PO1,PO3,P O5,PO9, <b>PSO1</b>
3	Propello	National	28-03- 2018	Student will be able to know basic concept propulsion.	PO1,PO3,P O9
4	Cut 2 Design	National	27-03-	Student will be able to apply	PO1,PO3

## [SELF ASSESSMENT REPORT]



			2018	concept of Engineering drawing.	
5	Fork Lifter	National	28-03-2018	Student will be able to build a crane model using wooden material suitable enough to place the given weights on a platform using only hydraulic mechanism.	PO1,PO3,PO9, <b>PSO1</b>
6	Brain quest	National	26-03-2018	Student will be able to improve their technical and general knowledge.	PO1
7	R-Mech Olympiad	National	27-03-2018	Student will be able to improve their core technical subjects knowledge.	PO1
8	Cadd mania	National	25-03-2018	Student will be able to improve their designing skill.	PO1,PO5, <b>PSO2</b>



Technical Event: **CADDMANIA**

Description: **AUTO-CAD Event**

Date: **25-03-2018**

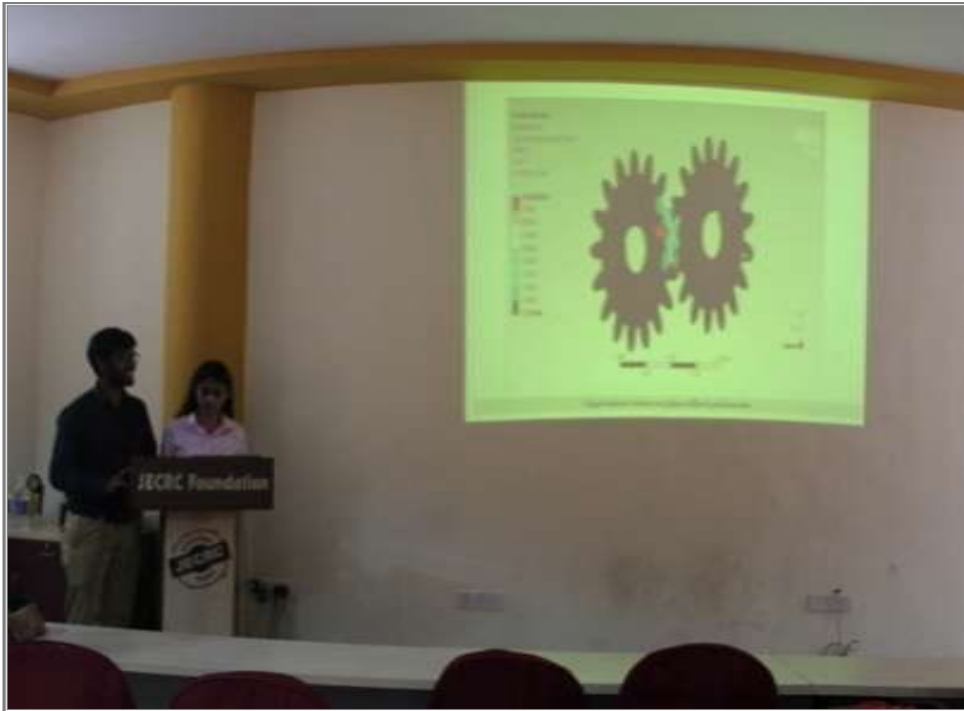

Technical Event: **EMBRYO**

Description: **Paper Presentation**

Date: **25-03-2018 & 26-03-2018**



Technical Event: **MIGHTY THROTTLE**

Description: **RC Car Event**

Date: **26-03-2018**



Technical Event: **BRAINQUEST**

Description: **Technical Knowledge Event**

Date: **26-03-2018**



Technical Event: **CUT-2-DESIGN**

Description: **Engineering Drawings Skills Event**

Date: **27-03-2018**



Technical Event: **R-MECH OLYMPIAD**

Description: **Technical Knowledge Event**

Date: **27-03-2018**



Technical Event: **FORK LIFTER**

Description: **Hydraulic Crane Event**

Date: **28-03-2018**



Technical Event: **PROPELLO**

Description: **Hydraulic Rocket Event**

Date: **28-03-2018**



**2.2. Teaching - Learning Processes (100)**

**2.2.1. Describe Processes followed to improve quality of Teaching & Learning (25)**

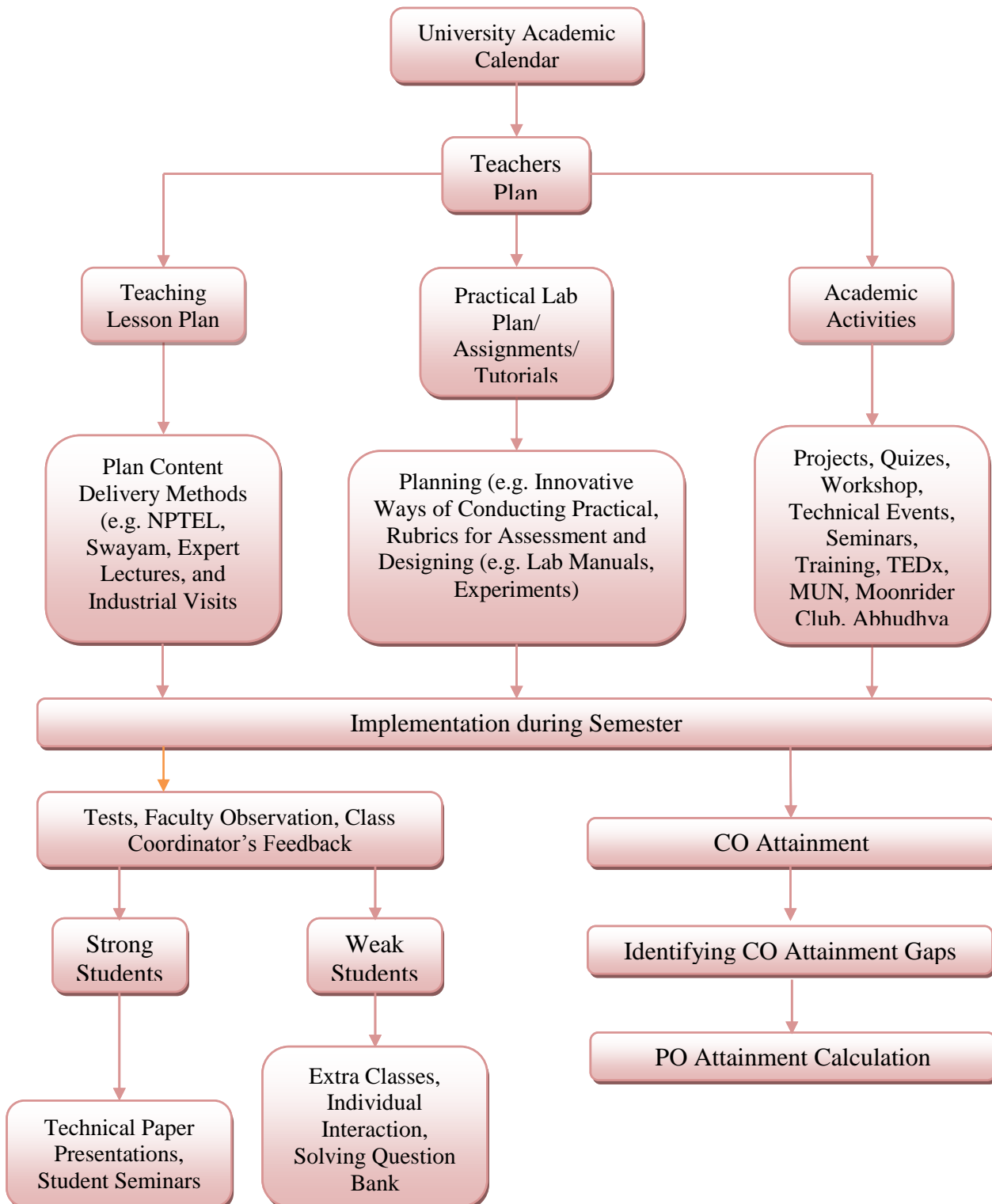

## [SELF ASSESSMENT REPORT]

---



- Faculty members are oriented towards Outcome based Education (OBE) and are actively utilizing the OBE to cater the learning needs of students by innovative ways.
- As per RTU norms, rather than referring Academic Calendar published on the university's website, the department publishes its own Academic Calendar involving the regular teaching plan as well as other extra student centric activities. It also includes the intimation of regular Midterm examinations and class tests.
- Lecture Delivery is made innovative in the department by inculcating various methods in the teaching learning process like recalling prior related topics, generating questions, responding to generated queries, etc. All these methods are generally performed in cooperative approach like Group Discussions and Seminars.
- In labs, the delivery to the students is performed with the help of latest software and performance of each student is evaluated in the Lab Performance Report. Viva voce and seminars are taken in the respective labs.
- Experiments in the laboratories are conducted as per the university guidelines. Some discussions are made beyond syllabus relevant to the course. Laboratory manuals explaining the details of the experiment are available with the course teacher and are given to students during the semester.
- Faculty members not only provide well written unit wise notes but also focuses on the materials provided online by the well renowned universities. They focus on the video lecture material provided to the students online e.g. NPTEL, SWAYAM. It enhances the capability of students to not only understand the context but also its practical approaches.
- Oral Questionnaire and Query Session in each lecture delivery of respective subjects.
- Class Tests and Assignments are being taken by faculty members for each respective subject.
- Performance Report is discusses to the students on regular basis.
- Mentoring sessions are conducted to provide guidance to students towards achieving professional requirements and assessment of his/her academic progress as well as personal growth. One-one discussion, interaction between faculty member and students has increased confidence levels of the students.



## [SELF ASSESSMENT REPORT]

---



- Department has club named 'Moonriders Club'. We design and manufacture various automobiles and projects in campus and till now it has been part of various events like ATV, Go-Kart, Efficycles, RC-Car and RC-Plane.
- The department organized conferences, workshops and guest lecturers to create a culture of instilling and nurturing research creativity and scientific temper among the learners.
- Projects are mandatory for VII Sem and VIII Sem students. Students make their minor and major projects under the supervision of their respective Guide Faculty members.
- Faculty Development Programs are organized in the department to ensure that the faculty members have the knowledge of latest technologies.
- The department has provision of showing answer sheets of internal examination to the students. They can compare their answer with other students and also with text books. They can discuss with respective subject teacher. Faculty members are use assignments, tutorials, quiz etc. This has added value to the system.
- The department gives emphasis on concept building and exposure of latest knowledge of the subject. For this following measures are taken: practical exposure, communication skill and social responsibilities.
- For developing communication skills, group discussions, presentation on theory based and general topics are regularly carried out in the class.
- Course outcomes are defined not only for the subjects but their respective labs also. Then course outcomes are mapped with the program outcomes. This mapping depicts the achievement of the particular learning outcome.
- The examination evaluation is also performed on the basis of course outcomes which ensure the result of the achievement of outcomes. Generally this criterion for achievement is 60%.
- The midterm exams are evaluated on the basis of course outcomes. 60% achievement of each student in the respective subject ensures the achievement of the course outcome. If any student doesn't achieve the required criteria, he/she is given the assignments related to those course outcomes in which the student did not secure 60% marks.

## [SELF ASSESSMENT REPORT]



- The bright students having high academic track records are encouraged by faculty members to achieve university ranks, also encouraged to take up competitive examinations like GATE, GRE etc. The faculty members encourage the students, those having orientation towards research to do research work and publish their research work in National & International Conferences and Journals.

### Sample of Course Plan

Course Plan							
<b>Subject name:</b> <b>Refrigeration and air conditioning</b> <b>Subject Code: 7ME2A</b> <b>Year:4<sup>th</sup></b> <b>Semester: 7<sup>th</sup></b>		<b>POs</b> <b>PO1; PO2;</b> <b>PO3;PO6;PO7;</b> <b>PO12</b>		<b>Cos</b> 1. To apply the fundamentals of sciences and engineering for understanding the working of different types of refrigeration systems. 2. To analyze the effect of different refrigeration conditions on the performance of refrigerator and environment. 3. To identify best refrigeration system and component of refrigeration system according to need of customers. 4. To design air condition unit according to the specific need of customers.			
S. No.	Lecture No.	Topic to be discussed	COs	Objective of Unit	Outcome of Lecture and CO	Methods	From page to
					Students are able to:-		
UNIT -1	1	Introduction of refrigeration and second law of Thermodynamics, Refrigeration unit, Heat pump, reversed Carnot cycle.	CO1	Understand vapour compression system; analyze the vapour refrigeration cycles and methods for improving the performance of cycle.	understand about basics of refrigeration	Chalk and Talk	T3(64-84); T2(25-25)
	2	Vapour Compression Refrigeration System:, Analysis of simple vapour compression Refrigeration cycle by PH, TS diagram	CO2		understand about vapour compression refrigeration cycle	Chalk and Talk	T3(87-89);
	3	Effect of operating conditions, actual refrigeration cycle	CO1		understand about the effect of operating condition on C.O.P	Chalk and Talk	T3(87-89); T3(91)
	4	Problems	CO1 CO2		calculate the refrigeration load and C.O.P of cycle	Chalk and Talk	T3(94-95)

## [SELF ASSESSMENT REPORT]



	5	Problems	CO1 CO2		calculate the refrigeration load and C.O.P of cycle	Chalk and Talk	T3(96-99)
	6	Application of Multiple Evaporator and Compressor System, air compressor system, Individual compressor,	CO2		the effect of multiple evaporator and compressor on refrigerating capacity	Chalk and Talk	T3(214-216) T3(222-225)
	7	compound compression, cascade system	CO2		the effect of multiple evaporator and compressor on refrigerating capacity	Chalk and Talk	T3(218); T3(226-228);T2 (113)
	8	Problems	CO1 CO2		calculate the refrigeration load with multiple component and C.O.P of cycle	Chalk and Talk	T3(219-221)
UNIT -2	9	Introduction of Gas Cycle Refrigeration, Limitation of Carnot cycle with gas, reversed Brayton cycle	CO1 CO2	Understand air refrigeration system operations and analyse the air refrigeration cycles and methods for improving the performance of cycle.	understand about gas refrigeration cycle and limitations of cycle	Chalk and Talk	T3(367-383)
	10	Problems	CO1 CO2		calculate the refrigerant effect and C.O.P of simple system	Chalk and Talk	T3(374-376)
	11	Brayton cycle with regenerative heat exchanger, Air cycle for air craft	CO1 CO2		understand the methods for improving the performance of cycle	Chalk and Talk	T3(377-381)
	12	Problems	CO1 CO2		calculate the refrigerant effect and C.O.P of improved system	Chalk and Talk	T3(381-383)
	13	Necessity of cooling of air craft, Basic cycle, boot strap regenerative type air craft refrigeration cycle	CO1 CO2		understand about refrigeration cycles use in air crafts	Chalk and Talk	T3(378)

# [SELF ASSESSMENT REPORT]



	14	Problems	CO1 CO2		calculate the refrigerant effect and C.O.P of air craft refrigeration system	Chalk and Talk	T3(400-401)
	15	Problems	CO1 CO2		calculate the refrigerant effect and C.O.P of air craft refrigeration system	Chalk and Talk	
UNIT -3	16	Introduction of Vapour Absorption System, Simple Vapour absorption system, Analysis of Ammonia absorption refrigeration system	CO1, CO2 CO3	Understand vapour absorption system operation, selection of refrigerants, Familiarize the components of refrigeration systems	understand about vapour absorption refrigeration systems	Chalk and Talk Projector	T3(402-405);
	17	Electrolux Refrigerator, Lithium Bromide Absorption Refrigeration System.	CO1, CO2 CO3		understand about vapour absorption refrigeration systems	Chalk and Talk Projector	T3(423-425); T3(431-432)
	18	Classification and Nomenclature of refrigerants,	CO1,		understand about the nomenclature and desired properties of refrigerant	Chalk and Talk	T3(128-129);
	19	Selection of refrigerants, global warming potential of CFC Refrigerants	CO1, CO2		understand the effect of refrigerant on environment	Chalk and Talk	T3(136; 153); T2(335-337)
	20	Type and working of refrigeration compressors	CO3		understand different types of refrigeration compressors	Projector	T2 (146-147;170-172)
	21	Type and working of refrigeration condensers	CO3		understand different types of refrigeration compressors	Projector	T3(286-300)
	22	Type and working of refrigeration evaporators	CO3		understand different types of refrigeration evaporators	Projector	T3(319-333)
	23	Type and working of refrigeration expansion	CO3		understand different types of refrigeration expansion	Projector	T3(303-310)

# [SELF ASSESSMENT REPORT]



		devices			devices		
UNIT -4	24	Introduction of air conditioning,	CO4	Understand air conditioning systems and process. Calculations of psychometric process for cooling, heating load estimation.	understand about basics of air conditioning systems and psychometric properties	Chalk and Talk	T1 (40-43); T3(446-447)
	25	Psychometric properties, psychometric relations, Problems	CO4		calculate simple problems of cooling load estimation	Chalk and Talk	T1 (40-42) : T3 (452-458)
	26	psychometric charts, Psychometric processes, cooling coils, By-pass factor and air washers	CO4		understand about different psychometric process and calculation	Chalk and Talk Projector	T3 (465-471; 478-484; 486-491); T1 (43-46)
	27	Problems	CO4		calculate cooling/heating load for air conditioning unit	Chalk and Talk	T3 (464,485)
	28	Problems	CO4		calculate cooling/heating load for air conditioning unit	Chalk and Talk	T3 (475-476; 492-493;)
	29	Problems	CO4		calculate cooling/heating load for air conditioning unit	Chalk and Talk	T3 (495-496)
	30	Mechanism of body heat losses, factors affecting human comfort, effective temperature,	CO4		understand different factors affecting human comfort	Chalk and Talk Projector	T3 (516-521)
	31	comfort chart	CO4		use of comfort chart	Chalk and Talk Projector	
UNIT -5	32	Cooling Load Calculations: Internal heat gain, system heat gain, RSHF	CO4	Design air conditioning systems using cooling load estimation	calculate total sensible heat load and total latent heat load for a room	Chalk and Talk Projector	T3 (497-500; 502-503; 508-509)
	33	ERSHF, GSHF, cooling load estimation, heating load estimation	CO4		estimate total cooling load of the room for human comfort	Chalk and Talk Projector	T3 (622-630); T1(63-69)
	34	Problems	CO4		design air conditioning system according to	Chalk and Talk	T3 (501-504)

## [SELF ASSESSMENT REPORT]



				human comfort		
35	Problems	CO4		design air conditioning system according to human comfort	Chalk and Talk	T3 (505-508)
36	Problems	CO4		design air conditioning system according to human comfort	Chalk and Talk	T3 (509-511)
37	selection of air conditioning apparatus for cooling	CO4		Understand about the selection of apparatus for cooling, heating	Chalk and Talk	T3(662-667)
38	Dehumidification, air conditioning system.	CO4		Understand about the selection of apparatus for humidification and dehumidification	Chalk and Talk	T2(842-845;869-870)
39	Problems	CO1-CO4		estimate human comfort condition for a desire space	Chalk and Talk	T3 (630-638;643-6465;647-648)
40	problems	CO1-CO4		estimate human comfort condition for a desire space	Chalk and Talk	
<b>Recommended books:</b>		<b>T1:</b> Refrigeration and Air Conditioning, Stoecker W.F., McGraw Hill Publication. <b>T2:</b> Modern Refrigeration and Air Conditioning, Andrew D. Althouse, Good Heart-Willcox Co. <b>T3:</b> Refrigeration and Air Conditioning, Arora C.P., Tata McGraw Hill New Delhi				

### 2.2.2. Quality of internal semester Question papers, Assignments and Evaluation (20)

#### Question papers

- To ensure the quality of internal semester question papers, solution of question papers and scrutinization of answer sheets, the department has drafted a committee named as Moderation and scrutinizing Committee. The following members being the part of this Committee: The information related to Moderation and scrutinizing Committee is given in table.

## [SELF ASSESSMENT REPORT]



### Moderation and scrutinizing Committee (2018-19)

S#	Faculty	Qualification	Designation	Role
1	Dr. M.P. Singh	B.E, M.Tech, Ph.D	HOD	Chair
2	Dr.Fauzia Siddiqui	B.Tech, M.Tech, Ph.D	Professor	Member
3	Dr. Bhuvnesh Bhardwaj	B.E, M.Tech, Ph.D	Associate Professor	Member
4	Dr. Manish Shrivastava	B.E, M.Tech, Ph.D	Assistant Professor	Member

### Moderation and scrutinizing Committee (2017-18)

S#	Faculty	Qualification	Designation	Role
1	Dr. M.P. Singh	B.E, M.Tech, Ph.D	HOD	Chair
2	Mr. Manish Jain	B.E, M.Tech, Ph.D (Pur.)	Associate Professor	Member
3	Dr. Bhuvnesh Bhardwaj	B.E, M.Tech, Ph.D	Associate Professor	Member
4	Dr. Manish Shrivastava	B.E, M.Tech, Ph.D	Assistant Professor	Member

### Moderation and scrutinizing Committee (2016-17)

S#	Faculty	Qualification	Designation	Role
1	Mr. Manish Jain	B.E, M.Tech, Ph.D (Pur.)	HOD	Chair
2	Dr. M.P. Singh	B.E, M.Tech, Ph.D	Professor	Member
3	Dr. Bhuvnesh Bhardwaj	B.E, M.Tech, Ph.D	Associate Professor	Member
4	Dr. Manish Shrivastava	B.E, M.Tech, Ph.D	Assistant Professor	Member

## [SELF ASSESSMENT REPORT]



### Moderation and scrutinizing Committee (2015-16)

S#	Faculty	Qualification	Designation	Role
1	Mr. Manish Jain	B.E, M.Tech, Ph.D (Pur.)	HOD	Chair
2	Mr. Lalit Kumar Sharma	B.E, M.Tech,	Assistant Professor	Member
3	Mr. Bhuvnesh Bhardwaj	B.E, M.Tech, Ph.D(Pur.)	Assistant Professor	Member
4	Dr. Manish Shrivastava	B.E, M.Tech, Ph.D	Assistant Professor	Member

- The questions are mainly prepared according to Course Outcomes (COs).
- The question paper for each subject is divided in different sections. The first section of the question paper includes the objective questions from previous GATE, PSUs, etc.
- Other sections of question (theory/ numerical) paper include the questions from previous year university examination question papers.
- According to level of toughness the questions are prepared (viz., analyzing the problems, implementation of modern tools, formulating the problems etc.).



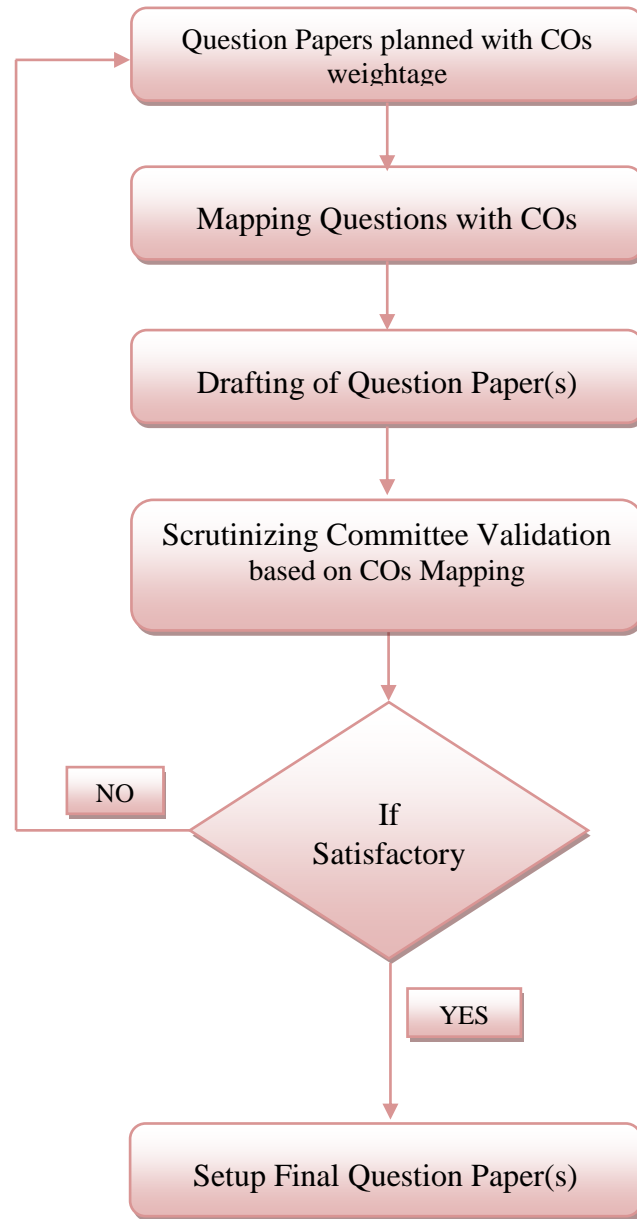

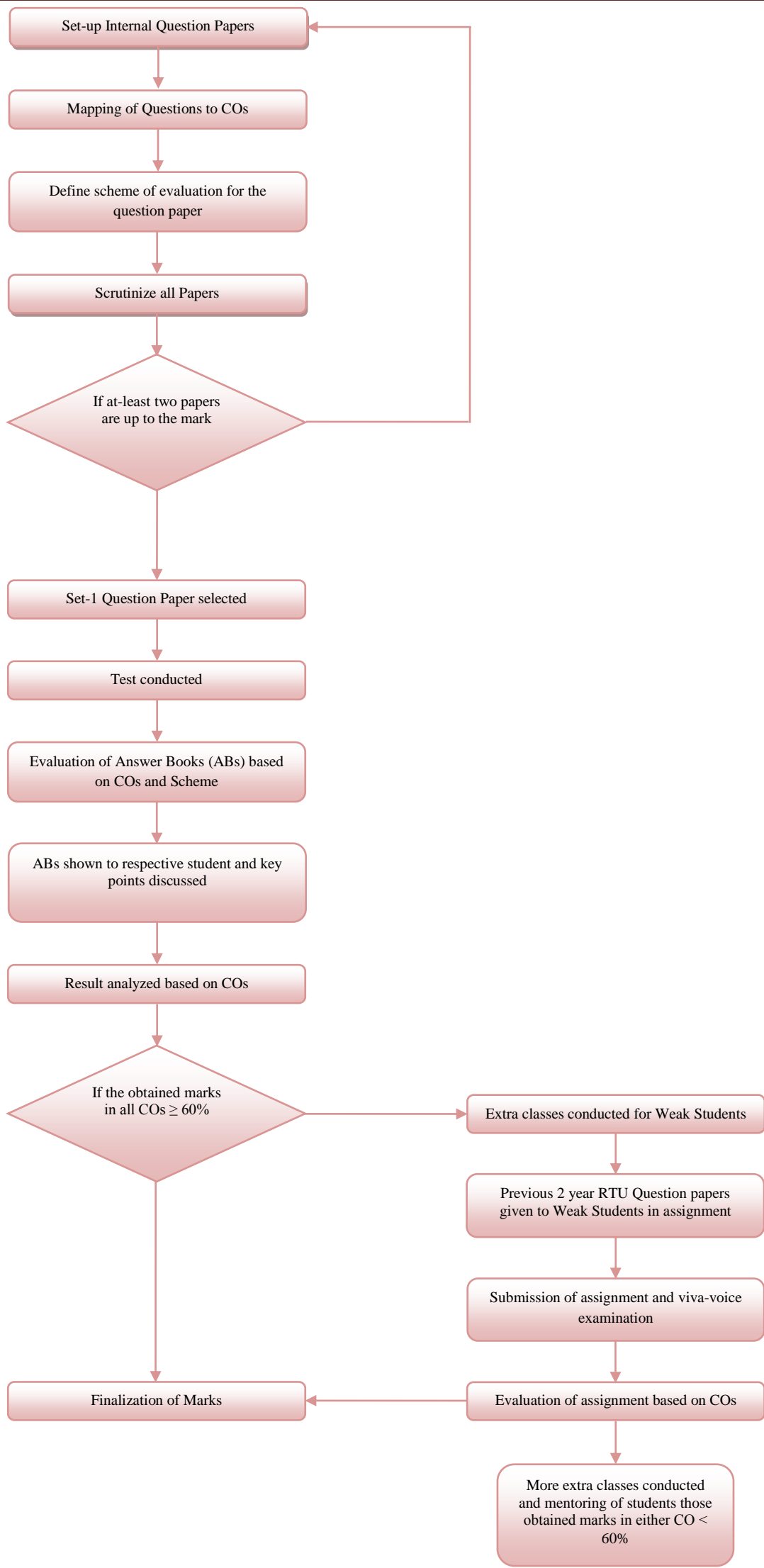

Figure 2.6 Evaluation Process

# [SELF ASSESSMENT REPORT]



<p style="text-align: center;"><b>JAIPUR ENGINEERING COLLEGE AND RESEARCH CENTRE</b> Department of Mechanical Engineering SEMESTER- VIII</p> <p>COURSE : B.Tech. SECTION : A/B/C SUBJECT : PDL CODE : SME4.1A TIME : 1.30 hrs. MTT-1 MM: 40 [Session- 2017-18]</p> <p><b>COURSE OUTCOMES:</b> CO1 To apply techniques to generate new product ideas and translate them into clear sketches. CO2 To analyze the need of product and new product (both, goods and services) and carry out a methodical approach to the management of product development to satisfy customer needs.</p> <p><b>Instructions: Attempt all sections</b></p> <p style="text-align: center;"><b>SECTION-A</b></p> <p><b>Attempt all questions (True/False)</b> [10x1]</p> <p>Q1:CO1 New-product development starts with idea generation. [True/False]</p> <p>Q2:CO1 The input of the planning phase is the project's mission statement. [True/False]</p> <p>Q3:CO1 Concept generation and selection are the only activities of concept development process. [True/False]</p> <p>Q4:CO1 Software, cellular phones, motors and switches are high risk products. [True/False]</p> <p>Q5:CO1 Technology-push products are known as generic products. [True/False]</p> <p>Q6:CO3 The purpose of idea generation is to generate a _____ number of ideas.</p> <p>Q7:CO3 A specification consists of a _____ and a _____.</p> <p>Q8:CO3 Team sets target specifications just before identifying the customer needs. [True/False]</p> <p>Q9:CO3 The most useful metrics are those that reflect as directly as possible the degree to which the product satisfies the customer needs. [True/False]</p> <p>Q10:CO3 Benchmarking exercise can't help in identifying differences with competitive products and taking positioning decisions. [True/False]</p>	<p style="text-align: center;"><b>SECTION-B</b></p> <p><b>Attempt any one part</b></p> <p>Q1:CO1 Write briefly on: [5x3]</p> <p>(i) Need Based Products (ii) Technology Push Products (iii) Platform based Products</p> <p style="text-align: center;">OR</p> <p>Q2(a):CO1 Discuss the importance of growth of enterprise with a suitable example. [7]</p> <p>Q2(b):CO1 Describe various stages involve in new product development process. [8]</p> <p style="text-align: center;"><b>SECTION-C</b></p> <p><b>Attempt any one part</b></p> <p>Q1(a):CO3 Write briefly on: [4x2]</p> <p>(i) Economic existence of need. (ii) Need Analysis.</p> <p>Q1(b):CO3 Explain the process of the need identification. [7]</p> <p style="text-align: center;">OR</p> <p>Q2:CO3 What do you mean by target marketing ? Explain the all the activities of target marketing ? [15]</p>
---	--

JAIPUR ENGINEERING COLLEGE AND RESEARCH CENTRE ( Affiliated to Rajasthan Technical University, Kota) AWARD LIST (2017 - 2018) [MTT-I]								
Class: III B. Tech. V Semester					Branch: Mechanical Engineering			
Subject & Code: Dynamics of Machines [SME2A]					Faculty: Lalit Kumar Sharma			
S. No.	RTU Roll No.	Name of student	Marks CO1 (MM 13)	Marks CO2 (MM 13)	Marks CO3 (MM 14)	Target Achieved CO1 (Y/N)	Target Achieved CO2 (Y/N)	Target Achieved CO3 (Y/N)
1		AA YUSH KUMAR AGRAWAL	12	3	8	Y	N	N
2		ABHIJEET						
3		ABHIJEET SINGH RATHORE	12	2	7	Y	N	N
4		ABHISHEK BANTHIA	12	2	3	Y	N	N
5		ABHISHEK KUMAR	5	2	4	N	N	N
6		ABHISHEK SAINI	12	6	5	Y	N	N
7		ABHISHEK SINGH	12	6	3	Y	N	N
8		ADITYA AGARWAL	7	2	6	N	N	N
9		ADITYA AGRAWAL	8	2	2	Y	N	N
10		ADITYA JAIN	12	5	4	Y	N	N
11		ADITYA SHARMA						
12		AKASH SAINI	11	8	4	Y	Y	N
13		AKASH SHARMA	9	2	7	Y	N	N
14		AKSHAY KUMAR	13	9	13	Y	Y	Y
15		ALANKAR SINGH	11	4	6	Y	N	N
16		AMAN SHARMA	11	6	4	Y	Y	N
17		AMARJEET KUMAR	10	4	3	Y	N	N
18		AMIT GOYAL	12	6	13	Y	N	Y
19		ANANG KUMAR PATIDAR	11	8	4	Y	Y	N
20		ANIRUDH SINGH CHOUHAN						
21		ANKIT KHANDLWAL	10	7	6	Y	N	N
22		ANSHUL GUPTA	4	4	3	N	N	N
23		ARJUN SINGH DEORA	7.5	10	7	N	Y	N
24		ARPIT KHANDLWAL	11.5	3	7	Y	N	N
25		ARSHDEEP SINGH						
26		ASHISH PRAJAPAT						
27		ASHUTOSH DADHICH	8	4	6	Y	N	N
28		BHANU PRAKASH GUPTA	13	6	5	Y	N	N
29		BHARAT PURSANANI	10	6	7	Y	Y	N
30		BHUVNESH KUMAR YADAV	13	8	13	Y	Y	Y
31		CHANDRA PRAKASH FULWANI	5	11	14	N	Y	Y
32		DARSH PANDEY	9	4	6	Y	N	N
33		DEEPAK MITTAL	13	2	4	Y	N	N
34		DEEPAK RAJPUROHIT	3	3	2	N	N	N
35		DEVENDRA PRATAP YADAV	12	5	12	Y	N	Y
		Faculty	Class Coordinator		Programme Coordinator			
		(Name & Signature)	(Name & Signature)		(Name & Signature)			

# [SELF ASSESSMENT REPORT]



JAIPUR ENGINEERING COLLEGE AND RESEARCH CENTRE (Affiliated to Rajasthan Technical University, Kota)								
AWARD LIST (2017 - 2018)						[MTT-I]		
Class: III B. Tech. V Semester				Branch: Mechanical Engineering				
Subject & Code: Dynamics of Machines [SME2A]				Faculty: Lalit Kumar Sharma				
S. No.	RTU Roll No.	Name of student	Marks CO1 (MM 13)	Marks CO2 (MM 13)	Marks CO3 (MM 14)	Target Achieved CO1 (Y/N)	Target Achieved CO2 (Y/N)	Target Achieved CO3 (Y/N)
36		DEVESH LALA	12	12	14	Y	Y	Y
37		DHRUV RAJ PUROHIT	11	9	3	Y	Y	N
38		DIVYANK RATHI						
39		GAURAV DEVRA						
40		GAURAV KUMAR GUPTA	9	13	3	Y	Y	N
41		HARISH SHARMA	9	9	3	Y	Y	N
42		HARSH MANTRI	9	2	7	Y	N	N
43		HARSHIL PANDIT	7	5	6	N	N	N
44		HARSHIT JAIN	10.5	2	8	Y	N	N
45		HEMANT SINGH CHAUHAN	13	5.5	10	Y	N	Y
46		HEMANT SINGH SISODIYA	7	7	8	N	N	N
47		HIMANSHU BANSAL	12	11	13	Y	Y	Y
48		HIMANSHU JANGIR	11	9	3	Y	Y	N
49		HIMANSHU PAGARIYA	7	2	6	N	N	N
50		HITESH KUMAR YADAV	10	2	3	Y	N	N
51		JAIDEEP MAHENDRA	10.5	3	7	Y	N	N
52		JAY KANT JOSHI	4	2	8	N	N	N
53		JITENDRA DEVNANI	6	10	4	N	Y	N
54		JITENDRA MOHAN SHARMA	11	2	4	Y	N	N
55		KAPTAN SINGH	3	4	4	N	N	N
56		KASHISH JAIN	12	9	12	Y	Y	Y
57		LOKESH KHANDELWAL	8.5	6	12	Y	N	Y
58		MADHUSUDAN SAINI	9	6	6	Y	N	N
59		MANISH KUMAR	12	12	6	Y	Y	N
60		MAYANK KOCHAR	12	13	11	Y	Y	Y
61		MAYANK SHARMA	13	8	13	Y	Y	Y
62		MD AMIQUE WAHID	7	12.5	7	N	Y	N
63		MD SHAHBAZ AKHTAR	12	3	14	Y	N	Y
64		MIHIR PANCHAL	6	5	3	N	N	N
65		MOHAMMED MONIS	12	11	6	Y	Y	N
66		MOHAMMED SAMEER	12	7	12	Y	N	Y
67		MOHAN CHOUDHARY						
68		MOHIT AGRAWAL	11	2	14	Y	N	Y
69		MOHIT CHANDANI	12	6	14	Y	N	Y
Average			9.8278689	8.3	10.2746			
Percentage			75.598931	63.846154	73.39			
Target Achieved			Y	Y	Y			
Faculty			Class Coordinator			Programme Coordinator		

JAIPUR ENGINEERING COLLEGE AND RESEARCH CENTRE (Affiliated to Rajasthan Technical University, Kota)								
AWARD LIST (2017 - 2018)						[MTT-I]		
Class: III B. Tech. V Semester				Branch: Mechanical Engineering				
Subject & Code: Dynamics of Machines [SME2A]				Faculty: Lalit Kumar Sharma				
LIST OF WEAK STUDENTS								
S. No.	RTU Roll No.	Name of student	CO1 (Y/N)	CO2 (Y/N)	CO3 (Y/N)	Assignment CO1 (Y/N)	Assignment CO2 (Y/N)	Assignment CO3 (Y/N)
1		AAYUSH KUMAR AGRAWAL	N	Y	Y	N	Y	Y
2		ABHIJEET						
3		ABHIJEET SINGH RATHORE	N	Y	Y	N	Y	Y
4		ABHISHEK BANTHIA	N	Y	Y	N	Y	Y
5		ABHISHEK KUMAR	Y	Y	Y	Y	Y	Y
6		ABHISHEK SAINI	N	Y	Y	N	Y	Y
7		ABHISHEK SINGH	N	Y	Y	N	Y	Y
8		ADITYA AGARWAL	Y	Y	Y	Y	Y	Y
9		ADITYA AGRAWAL	N	Y	Y	N	Y	Y
10		ADITYA JAIN	N	Y	Y	N	Y	Y
11		ADITYA SHARMA						
12		AKASH SAINI	N	N	Y	N	N	Y
13		AKASH SHARMA	N	Y	Y	N	Y	Y
14		AKSHAY KUMAR	N	N	N	N	N	N
15		ALANKAR SINGH	N	Y	Y	N	Y	Y
16		AMAN SHARMA	N	N	Y	N	N	Y
17		AMARJEET KUMAR	N	Y	Y	N	Y	Y
18		AMIT GOYAL	N	Y	N	N	Y	N
19		ANANG KUMAR PATIDAR	N	N	Y	N	N	Y
20		ANIRUDH SINGH CHOUHAN						
21		ANKIT KHANDELWAL	N	Y	Y	N	Y	Y
22		ANSHUL GUPTA	Y	Y	Y	Y	Y	Y
23		ARJUN SINGH DEORA	Y	N	Y	Y	N	Y
24		ARPIT KHANDELWAL	N	Y	Y	N	Y	Y
25		ARSHDEEP SINGH						
26		ASHISH PRAJAPAT						
27		ASHUTOSH DADHICH	N	Y	Y	N	Y	Y
28		BHANU PRAKASH GUPTA	N	Y	Y	N	Y	Y
29		BHARAT PURSANANI	N	N	Y	N	N	Y
30		BHUVNESH KUMAR YADAV	N	N	N	N	N	N
31		CHANDRA PRAKASH FULWANI	Y	N	N	Y	N	N
32		DARSH PANDEY	N	Y	Y	N	Y	Y
33		DEEPAK MITTAL	N	Y	Y	N	Y	Y
34		DEEPAK RAJPUROHIT	Y	Y	Y	Y	Y	Y
35		DEVENDRA PRATAP YADAV	N	Y	N	N	Y	N
Faculty			Class Coordinator			Programme Coordinator		
(Name & Signature)			(Name & Signature)			(Name & Signature)		

# [SELF ASSESSMENT REPORT]



JAIPUR ENGINEERING COLLEGE AND RESEARCH CENTRE								
( Affiliated to Rajasthan Technical University, Kota)								
AWARD LIST (2017 - 2018)						[MTT-I]		
Class: III B. Tech. V Semester					Branch: Mechanical Engineering			
Subject & Code: Dynamics of Machines [SME2A]					Faculty: Lalit Kumar Sharma			
<b>LIST OF WEAK STUDENTS</b>								
S. No.	RTU Roll No.	Name of student	CO1 (Y/N)	CO2 (Y/N)	CO3 (Y/N)	Assignment CO1 (Y/N)	Assignment CO2 (Y/N)	Assignment CO3 (Y/N)
36		DEVESH LALA	N	N	N	N	N	N
37		DHRUV RAJ PURDHIT	N	N	Y	N	N	Y
38		DIVYANK RATHI						
39		GAURAV DEVRA						
40		GAURAV KUMAR GUPTA	N	N	Y	N	N	Y
41		HARISH SHARMA	N	N	Y	N	N	Y
42		HARSH MANTRI	N	Y	Y	N	Y	Y
43		HARSHIL PANDIT	Y	Y	Y	Y	Y	Y
44		HARSHIT JAIN	N	Y	Y	N	Y	Y
45		HEMANT SINGH CHAUHAN	N	Y	N	N	Y	N
46		HEMANT SINGH SISODIYA	Y	Y	Y	Y	Y	Y
47		HIMANSHU BANSAL	N	N	N	N	N	N
48		HIMANSHU JANGIR	N	N	Y	N	N	Y
49		HIMANSHU PAGARIYA	Y	Y	Y	Y	Y	Y
50		HITESH KUMAR YADAV	N	Y	Y	N	Y	Y
51		JAIDEEP MAHENDRA	N	Y	Y	N	Y	Y
52		JAY KANT JOSHI	Y	Y	Y	Y	Y	Y
53		JITENDRA DEVNANI	Y	N	Y	Y	N	Y
54		JITENDRA MOHAN SHARMA	N	Y	Y	N	Y	Y
55		KAPTAN SINGH	Y	Y	Y	Y	Y	Y
56		KASHISH JAIN	N	N	N	N	N	N
57		LOKESH KHANDELWAL	N	Y	N	N	Y	N
58		MADHUSUDAN SAINI	N	Y	Y	N	Y	Y
59		MANISH KUMAR	N	N	Y	N	N	Y
60		MAYANK KOCHAR	N	N	N	N	N	N
61		MAYANK SHARMA	N	N	N	N	N	N
62		MD AMIQUE WAHID	Y	N	Y	Y	N	Y
63		MD SHAHBAZ AKHTAR	N	Y	N	N	Y	N
64		MIHIR PANCHAL	Y	Y	Y	Y	Y	Y
65		MOHAMMED MONIS	N	N	Y	N	N	Y
66		MOHAMMED SAMEER	N	Y	N	N	Y	N
67		MOHAN CHOUDHARY						
68		MOHIT AGRAWAL	N	Y	N	N	Y	N
69		MOHIT CHANDANI	N	Y	N	N	Y	N
Faculty			Class Coordinator			Programme Coordinator		
(Name & Signature)			(Name & Signature)			(Name & Signature)		

## ASSIGNMENT SHEET

JECRC  
Dynamics of Machines (SME2A)

### COURSE OUTCOME BASED

#### [CO1]

1. Explain the term height of the governor. Derive an expression for the height in the case of a Watt governor. What are the limitations of a Watt governor? What are the effects of friction and of adding a central weight to the sleeve of a Watt governor?
2. Discuss the controlling force and stability of a governor and show that the stability of a governor depends on the slope of the curve connecting the controlling force ( $F_c$ ) and radius of rotation ( $r$ ) and the value ( $F_c/r$ ).
3. A Hartnell governor having a central sleeve spring and two right-angled bell crank levers moves between 280 r.p.m. and 300 r.p.m. for a sleeve lift of 12mm. The sleeve arms and the ball arms are 75 mm and 110 mm respectively. The levers are pivoted at 100 mm from the governor axis and mass of each ball is 4 kg. The ball arms are parallel to the governor axis at the lowest equilibrium speed. Determine: (i) loads on the spring at the lowest and the highest equilibrium speeds, and (ii) stiffness of the spring.
4. A Porter governor has equal arms each 300 mm long and pivoted on the axis of rotation. Each ball has a mass of 8 kg and the mass of the central load on the sleeve is 40 kg. The radius of rotation of the ball is 175 mm when the governor begins to lift and 225 mm when the governor is at maximum speed. Find the range of speed, sleeve lift, governor effort and power of the governor in the following cases: (i) when the friction at the sleeve is neglected and (ii) when the friction at the sleeve is equivalent to 12 N.

[CO2]

1. Discuss the effect of the gyroscopic couple on a two wheeled vehicle when taking a turn.
2. A ship propelled by a turbine rotor which has a mass of 6 tonnes and a speed of 2000 r.p.m. The rotor has a radius of gyration of 0.8 m and rotates in a clockwise direction when viewed from the stern. Find the gyroscopic effects in the following conditions:
  - a. The ship sails at a speed of 36 km/h and steers to the left in a curve having 75 m radius.
  - b. The ship pitches 5 degree above and 5 degree below the horizontal position. The bow is ascending with its maximum velocity. The motion due to pitching is simple harmonic and the periodic time is 25 seconds.
  - c. The ship rolls and at a certain instant it has an angular velocity of 0.05 rad/s clockwise when viewed from stern.

Determine also the maximum angular acceleration during pitching. Explain how the direction of motion due to gyroscopic effect is determined in each case.

3. A four wheeled motor car of mass 2000 kg has a wheel base 2 m, track width 1 m and height of centre of gravity 0.4 m above the ground level and lies at 1 meter from the front axle. Each wheel has an effective diameter of 0.8 m and a moment of inertia of  $1 \text{ kg-m}^2$ . The drive shaft, engine flywheel and transmission are rotating at 5 times the speed of road wheel, in a clockwise direction when viewed from the front, and is equivalent to a mass of 80 kg having a radius of gyration of 90 mm. If the car is taking a right turn of 50 m radius at 50 km/h, find the load on each wheel.
4. The turning moment diagram of a multi cylinder engine has been drawn to a scale 1 mm = 500 N-m vertically and 1 mm =  $4^\circ$  horizontally. The intercepted areas between the between the output torque curve and the mean resistance line, taken in order from one end, are as follows: +50, -125, +90, -140, +85, -70, and +110  $\text{mm}^2$ , when the engine is running at as speed of 650 r.p.m. If the total fluctuation of speed is not to exceed  $\pm 1.2\%$  of the mean, find the necessary mass of the flywheel of radius 0.7 m.

## [SELF ASSESSMENT REPORT]



### 2.2.3. Quality of Student Projects (25)

The projects are mandatory for VII sem and VIII sem students. Students make their **minor and major projects** under the supervision of their respective Guide Faculty members. To ensure the quality of projects, department has drafted a committee named as **Project assessment Committee**.

#### Project assessment Committee for the year 2016-2017

S#	Faculty name	Qualification	Designation	Role
1	Mr. Manish Jain	B.E., M.Tech., Ph.D. (Purs.)	HOD	Chair
2	Dr. Bhuvnesh Bhardwaj	B.E., M.Tech., Ph.D.	Associate Professor	Project coordinator
3	Mr. Vipin Goyal	B.E., M.Tech.	Assistant Professor	Member
4	Mr. Ananya Chhattree	B.E., M.Tech.	Assistant Professor	Member

#### Mapping of project CO's with PO's

Subject & Code: Project (8MEPR)														
8ME PR Proje ct	1. To identify the given problem and acquire the system integration skills.	H	H	H	H	H	H	M		H			H	
	2. To handle project with overall safety concern.	H		H		M	H	H	H			H	H	
	3. To attain the documentation and communication skills.											H	H	H
	4. To analyze, formulate and integrate the project with managerial skills.	H	H	H	H	H	H	H	H	H	H	H	H	H



## **Project Identification**

- Project coordinator issues a circular to all faculty members to provide the list of five projects to be given to the students.
- Students are also encouraged to submit the idea of their own for doing the project.
- The project ideas received from the students and faculty members are filtered by the **Project assessment committee** on the basis of CO's i.e. Environment, Cost, Ethics, Safety, and Usefulness of the project.
- Final list of finalized projects has been made and display on notice board.
- The list of previous year projects is also displayed at notice board which ensures no repetition of project work and also encourages students to enhance the previous works.

## **Project Allotment**

- The student/team can select the project form the finalized list of projects according to their interest.
- If the student or group of students submit the own project idea, then careful examination according to CO's has been carried out by **Project Assessment Committee**. If the project idea submitted by the student/ group of students fulfills the basic requirements, then it will be allotted to that student/ group of students. If it does not fulfill the basic requirements, then a new project idea is allotted to that student/group of students from the list of finalized projects. The basic criterion for the acceptance and rejection is given table. If the marks are more than 5 then project is accepted otherwise rejected.
- A faculty member is appointed as a project guide to each group as per faculty's expertise field.



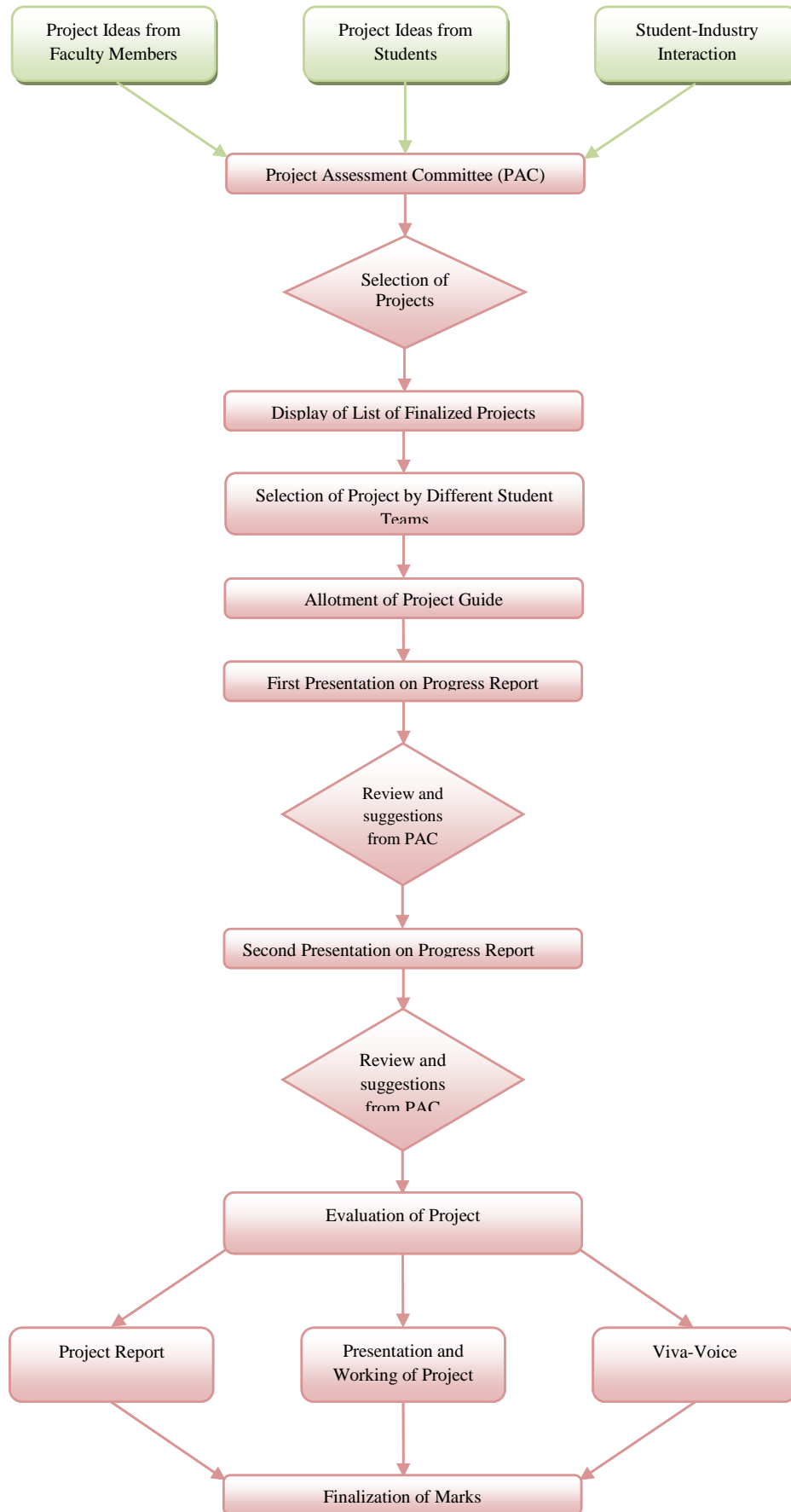

**Figure 2.7 Process of Project Evaluation**

# [SELF ASSESSMENT REPORT]



## Basic criterion for the selection or rejection of project

S#	Title of project	Evaluation (10)					Relevance with PO'S	Remarks
		Use fullness of the project (3)	Safety (2)	Ethics & Communication (2)	Project Management (3)	Total (10)	Relevance with PO'S	
1	X	1	2	2	1	8	PO1, PO2, PO3, PO6, PO8, PO9, PO11, PO12, <b>PSO1</b>	ACCEPT
2	Y	1	0	1	1	3	PO1, PO2, PO3, PO7	REJECT

### Project Continuous Monitoring

- Project coordinator displays the deadline on notice board for the progress report presentations and final submission of the project report.
- Each group has to submit progress report to the respective guide.
- Progress report presentation followed by viva-voce has been carried out twice in a semester in front of Project assessment committee, then Project assessment committee review the progress and gives suggestions.

### Project Evaluation

- A presentation followed by viva voce is also carried out at the end of VII semester in front of the external examiner and other students.
- Each group of students has to submit a report of their work along with the role of each team member after VII & VIII semester.
- The project exhibition is carried out at the end of VII semester. Student/group of students demonstrated the project in front of external examiner and other students.

# [SELF ASSESSMENT REPORT]



## Procedure for the selection of project

S #	Rol #	Team Members	Title of project	Project Guide	Evaluation (10)					Relevance with PO'S	Remarks
					Usefulness of the project (3)	Safety (2)	Ethics & Communication (2)	Project Management (3)	Total (10)	Relevance with PO'S	
1	7	Anirudh Kumar Jain	Simple water turbine model	Mr. Hemant Bansal	1	0	1	1	3	PO1, PO3, PO9, PO10, PO11	REJECT
	47	Jai Kishan Soni									
	61	Mahak Goyal									
2	2	Aishwarya Johari	All Wheel drive bike	Mr. Satyendra Kumar	2	2	0	2	6	PO1, PO2, PO3, PO4, PO9, PO10, PO11, PO12	ACCEPT
	14	Arpit Agarwal									
	24	Ayush Kumar Gupta									
	71	Pallav Pandey									
3	44	Himanshu Paliwal	Customised Air Cooling System	Mr. Shrikant Bansal	2	0	1	2	5	PO1, PO2, PO3, PO9, PO10, PO11, PO12	ACCEPT
	60	Mahak Bhatt									
	72	Piyush Kataria									
	73	Prashant Prajapati									
	78	Rahul Gupta									
4	33	Dhruv Laddha	Torque Generator Mechanism	Mr. Yogesh Dubey	1	0	0	2	3	PO1, PO2, PO3, PO9, PO10, PO11, PO12	REJECT
5	58	Lilleshwar Singh Rawat	Modified Cooler	Mr. Yogesh Dubey	1	0	1	1	3	PO1, PO2, PO3, PO9, PO10, PO11, PO12	REJECT
	76	Raghveer Singh Hada									
	77	Rahul Gahlot									
	102	Sudama Kumar									
6	39	Gaurav Vaishnav	Energy generation by suspension System	Mr. Kuldeep Sharma	2	1	1	2	6	PO1, PO2, PO9, PO10, PO11, PO12	ACCEPT
	40	Govind Kumar Poddar									

## [SELF ASSESSMENT REPORT]



	63	Md Quamre Alam									
	64	Mohit Saini									
7	23	Ashutos h Dhyani	Electro mechanic al Tricycle	Mr. Hemant Bansal	2	2	1	2	7	PO1, PO2, PO3, PO9, PO10, PO11, PO12	ACCEPT
	36	Dushyan t Jha									
	45	Himansh u Rai									
	50	Kalpesh Patidar									
8	25	Bharat Agarwal	Designing a power transmissi on system for ATV and calculatio n of efficiency and its various losses	Mr. Tejendr a Singh	3	2	0	2	7	PO1, PO2, PO3, PO9, PO5,PO10 , PO11, PO12	ACCEPT
	27	Chandra Mohan Sharma									
	30	Deepesh Mittal									
	66	Navneet Kumar									
9	10	Anmol Rajawat	Fabricatio n and modificati on of all season cooler	Mr. Hemant Bansal	2	1	1	3	7	PO1, PO2, PO3, PO6,PO9, PO10, PO11, PO12	ACCEPT
	11	Anshul Jain									
	13	Anurag Bansal									
	35	Dinesh Kumar Jain									
	59	Lincoln Gori									
10	37	Gagan Kumar Jindal	Fabricatio n of Go-Kart	Mr. Aashish Nagpal	2	2	0	3	7	PO1, PO2, PO3,PO4, PO5, PO9, PO10, PO11, PO12	ACCEPT
	43	Himansh u Gunesh war									
	48	Javed Khan									
	57	Lakshya Joshi									

# [SELF ASSESSMENT REPORT]



## Mapping of project with PO/PSO

S#	PROJECT NAME	PO / PSO
1	Design of car for specially - abled person	PO1,PO2,PO3,PO10,PO11,PO12/ PSO1,PSO2
2	All – Terrain vehicles	PO1,PO2,PO3,PO10,PO11,PO12/ PSO1,PSO2
3	LPG refrigerator	PO1,PO2,PO3,PO10,PO11,PO12
4	Hub less bike	PO1,PO2,PO3,PO10,PO11,PO12
5	Compressed air engine	PO1,PO2,PO3,PO10,PO11,PO12
6	Design and analysis of composites of piston cylinder head	PO1,PO2,PO3,PO10,PO11,PO12 / PSO2
7	Milling attachment	PO1,PO2,PO3,PO10,PO11,PO12
8	Fabrication and analysis of glass fiber composite	PO1,PO2,PO3,PO10,PO11,PO12
9	Design and Fabrication of Solar power steam Engine	PO1,PO2,PO3,PO10,PO11,PO12 / PSO2
10	Fabrication and Research on smart grinding attachment for lathe machine	PO1,PO2,PO3,PO4,PO10,PO11,PO12
11	Design and Fabrication of go cart	PO1,PO2,PO3,PO5,PO10,PO11,PO12/ PSO1,PSO2
12	Analysis of Solar vapor absorption system with different fluids	PO1,PO2,PO3,PO10,PO11,PO12
13	Analysis of fuel from plastic waste by pyrolysis Method	PO1,PO2,PO3,PO4,PO10,PO11,PO12



**Design of car for specially - abled person**

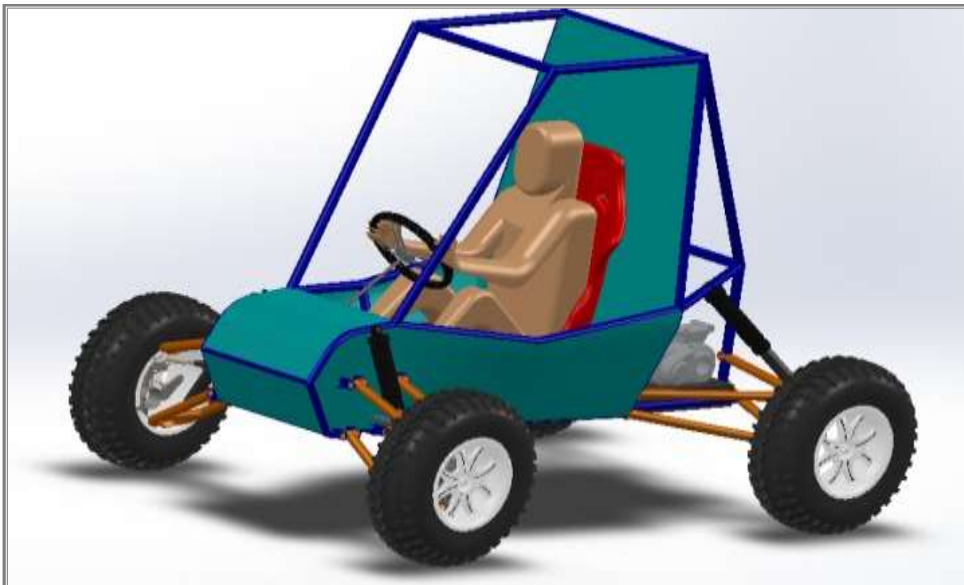

**All – Terrain vehicles**



**LPG refrigerator**



**Hub less bike**



Compressed air engine

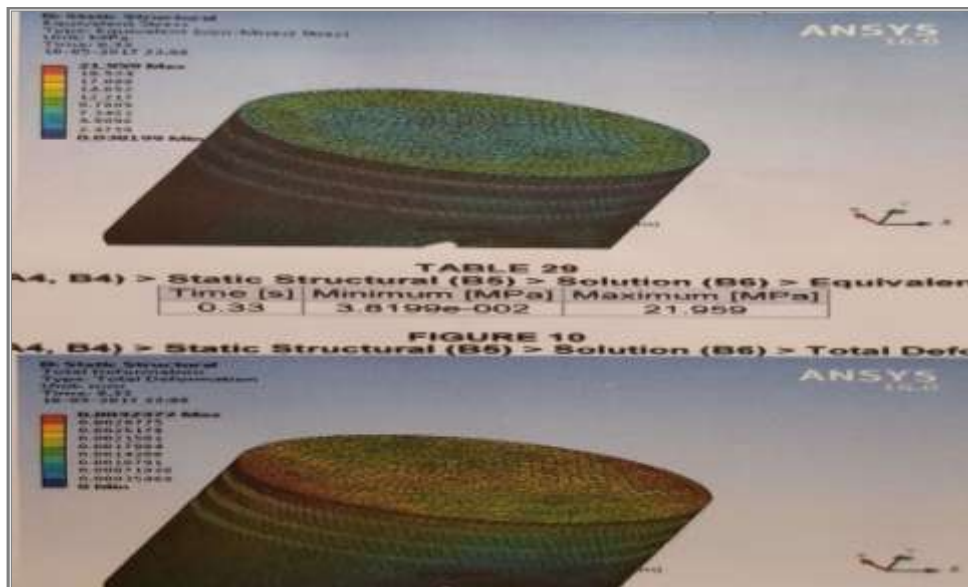

Design and analysis of composites of piston cylinder head



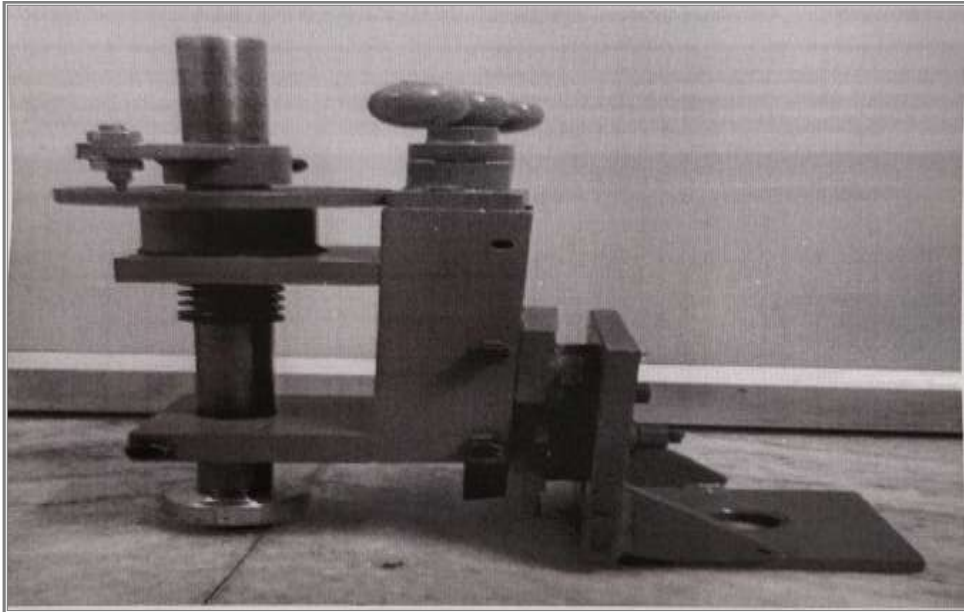

**Milling attachment**



**Fabrication and analysis of glass fiber composite**



**Design and Fabrication of Solar power steam Engine**

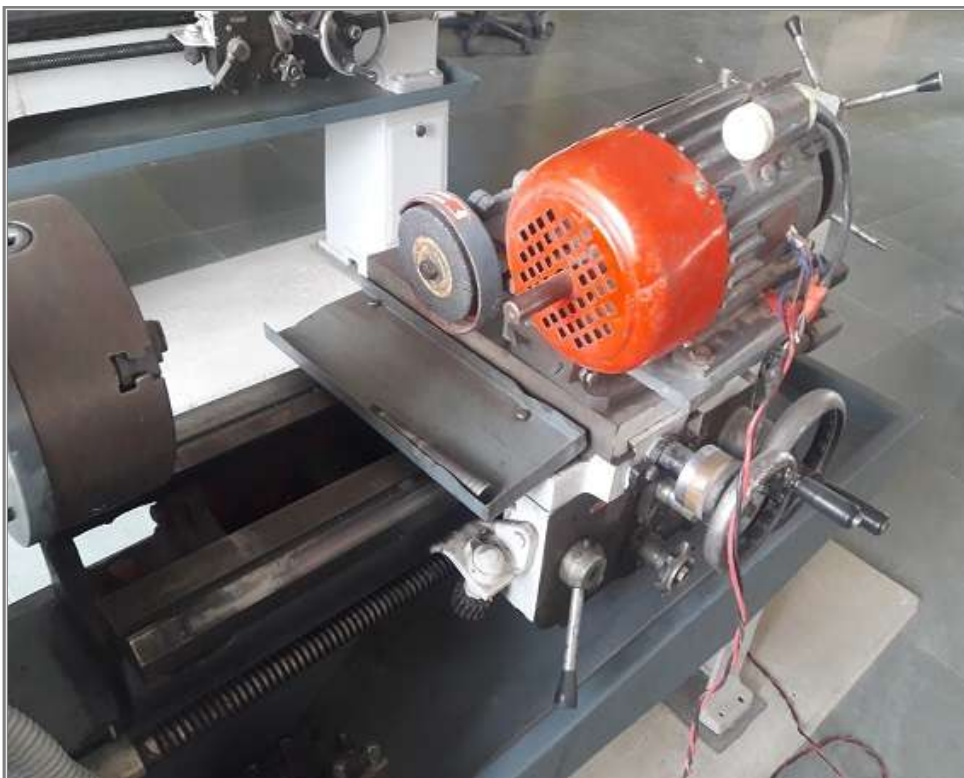

**Fabrication & Research on smart grinding attachment for lathe machine**



**Design and Fabrication of go cart**



**Analysis of fuel from plastic waste by pyrolysis Method**

# [SELF ASSESSMENT REPORT]



## Schedule for evaluation of project work

Phase	Sub. Code	Sem.	Nature of Work	Assessment
Phase I	Project Stage-1 7MEP R	VII	Introduction, Literature review, Research gap and objectives	Presentation-1
			Methodology, Cost estimation	Presentation-2
			Project report submission	Presentation & viva-voce
Phase II	Project Stage-2 8MEP R	VIII	Manufacturing / Prototype making (if require) and Collection of Data	Presentation-1
			Analysis of Data, Result and discussion and conclusion	Presentation-2
			Project report submission and university viva	Project Demonstration & viva-voce

### Scheme for the internal evaluation

S #	Title of project	Team Members	Project Guide	Presentation 1(15)			Presentation 1(15)			Total (30)
				Content (5)	Communication Skills (5)	Status (5)	Content (5)	Communication Skills (5)	Status (5)	

### Scheme for the external evaluation

S#	Title of project	Team Members	Project Guide	Final Evaluation(20)				
				Presentation Skills (2)	Demonstration (5)	Team Work (3)	Report (10)	Total (20)

## 2.2.4 Initiatives related to industry interaction (15)



The educational reform of linking technical education with industry is one of the important educational innovations emerging in this country. Interaction between institute and industry is now widely recognized as an essential requirement to train and develop the right kind of man power necessary to sustain and promote industrial and economical growth. To strengthen interaction with industries and to keep our students updated with the latest trends in mechanical engineering, the department has implemented following initiatives.

- Department entered into an MoU with CADD CENTRE, Jaipur for the benefit of the mechanical engineering students in the field of design.
- Special lecture by experts from industries have been conducted for exposing the industrial needs to the students.

- Students are permitted to take training at various industries.
- All students undertake summer/winter vacation training in industries which is mandatory.
- Faculty members/ department training and placement officer encourage the students to visit a wide range of technical exhibitions to keep them abreast of the scenario prevailing in their field of study. Thus the students undergoing the co-curricular training program get multi-faceted exposure to their respective engineering discipline.
- Industrial visits have been carried out along with the faculty members to bridge the gap between theoretical concepts and practical implications of the same.

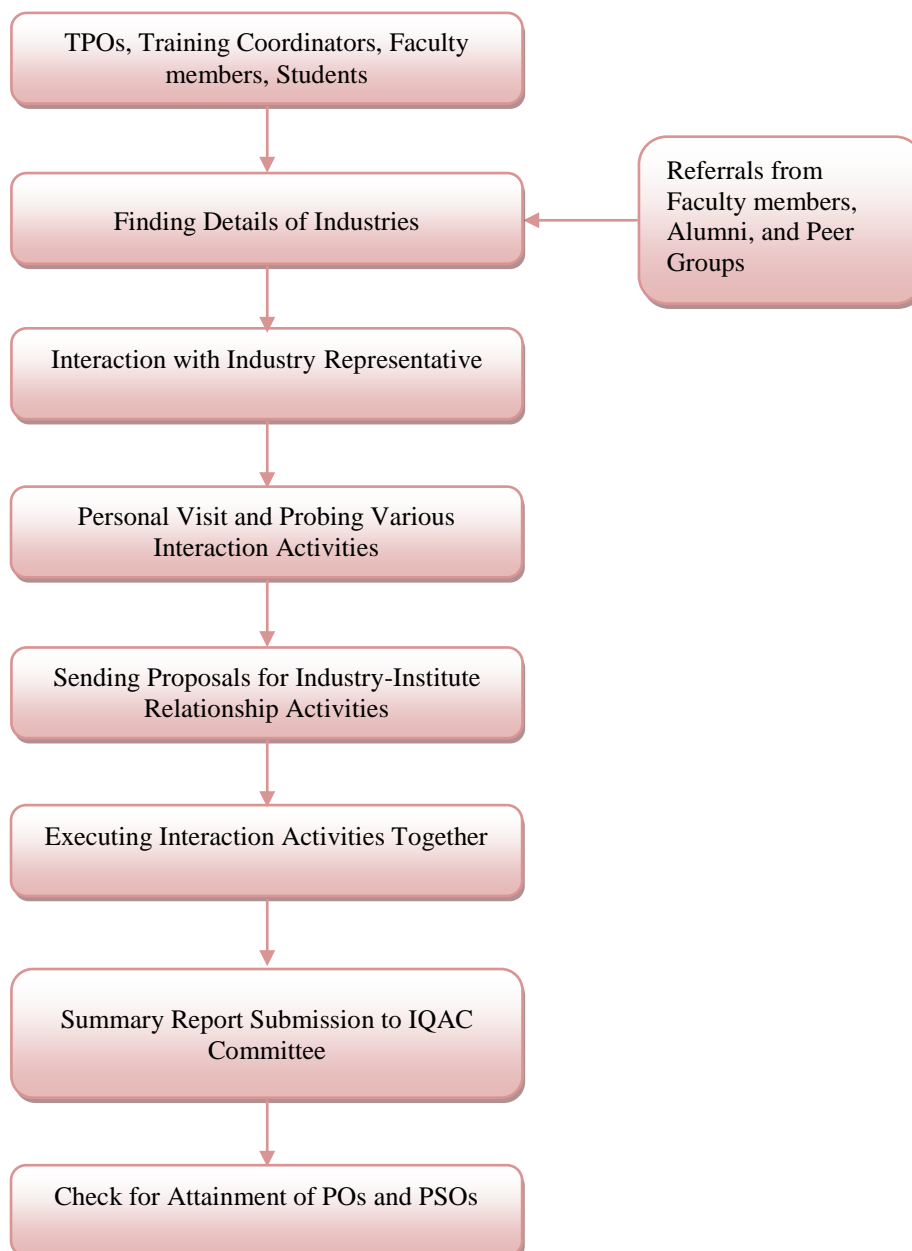

### **Procedure for the selection of industries for training**

## [SELF ASSESSMENT REPORT]



### Guest Lecture Conducted

S. No	Lecture/ Workshop/industrial visit	Date	Resource person	Name of organization	Relevance to POs
<b>(2016-2017)</b>					
1	Guest Lecture	01/10/2016	Mr. Nimesh Baba	Baba Automobile ltd. Jaipur	PO1,PO2,PO3,PO6,P07,PO12
2	Guest Lecture	17/10/2016	Mr. Pramod Vashistha	SKYFY Pvt. Ltd.	PO1,PO2,PO3,PO6,P07,PO12
3	Guest Lecture	17/02/2017	Mr. Alok Bhargava	Manu Yantralaya, Pvt. Ltd.	PO1,PO3,PO4,PO5,P06,PO7,PO12
4	Guest Lecture	10/03/2017	Mr. Amit Soni	Amit Tool Pvt. Ltd.	PO1,PO2,PO5,PO6,PO8,PO12
5	Guest Lecture	11/03/2017	Mr. Abhishek Singh	NEI	PO1,PO2,PO3,PO5,P06,PO12
6	Workshop	15/11/2016 - 19/11/2016	Mr. Nimesh Baba	Baba Automobile ltd. Jaipur	PO1,PO2,PO3,PO4,P05,PO6,PO7,PO12
7	Industrial Visit	15/2/ 2017	Mr. Anurag	CIPET, Jaipur	PO1,PO2,PO3,PO4,P05,PO12
<b>(2017-2018)</b>					
1	Industrial Visit	24-07-17	Mr. Pradeep Ojha	MSME	PO1,PO2,PO3,PO4,P05,PO12
2	Guest Lecture	11-08-17	Mr. Sandeep Chandalia	R-Tekhno Pvt. Ltd.	PO1,PO2,PO3,PO4,P05,PO6,PO12

## [SELF ASSESSMENT REPORT]



3	Guest Lecture	21/8/2017	Mr. Nimesh Baba	Baba Automobile ltd. Jaipur	PO1,PO2,PO3,PO4,P O5,PO12
4	Industrial Visit	06-09-2017	Mr. Rakesh Bangha	MSME	PO1,PO2,PO3,PO4,P O5,PO12
5	Industrial Visit	14/9/ 2017	Mr. Anurag	CIPET, Jaipur	PO1,PO2,PO5,PO6,P O7,PO12



# [SELF ASSESSMENT REPORT]



## Industrial Visit

### ME Team - Industrial Visit - Jan-Feb 2018

S #	Name of Team Members	Company Name	Concerned Person Name	Person's Designation	Person's Mob No.	Person's Email ID	Location	MOM of your meeting with concerned person
1	Yogesh Dubey	JINDAL SAW LTD.	Mr. R.S. Acharya	AVP-HR & Admin	8003699 872	rs.acharya@jindalsaw.com	Bhilwara	Interested in training, seminar and placement
		PUR VILLAGE	Mr. Tabish	HR	8003699 896			
2	& Vipin Goyal	SANGAM INDIA LTD	Mr. L.K. Nandwana	GM (Personnel)	8696948 152	lknandwana@gmail.com	Bhilwara	Interested in training
			Mr. Sushim Kabra	VP (Industrial Relation)	9928034 662 8875144 662	personnel@sangamgroup.com		
3		RSWML LTD. CHITTOR ROAD	Mr. Sudhir Tiwari	GM-HR (Head)	9414059 113	sudhir.tiwari@lnjbhilwara.com	Bhilwara	Interested in training
4	Yogesh	KANCHAN	Mr. Virender	Head-HR	9636413	akhilesh.shrm86@gm	Bhilwara	Interested in

## [SELF ASSESSMENT REPORT]



	Dubey &	INDIA LTD, DANTA NILAWRI	Singh Rathore  Mr. Akhilesh Sharma	 Manager (HR and Time Office	111  9636417 111	ail.com		training Interested in training
		BABA SPINNERS, (LAMBIA KALAN)	Mr. S.S. Solanki	Head-HR	7073451 935	solanki@babacollecti on.com	Bhilwara	Interested in training
5	Satya Prakash Saini	SANGAM INDIA LTD, SARERI	Mr. B.S. Kushwah	EVP (P & Admin)	9414113 677	hrmsareri@sangamgr oup.com	Bhilwara	Interested in training
6		SHREE CEMENT LIMITED, DEVLI, BEAWAR	Mr. Kuldeep Chaturvedi	Sr. GM-HR	7727002 541	chaturvedikuldeep@s hrecementltd.com	Bhilwara	Interested in training
7		Shubhank Sharma	Strykers	Mr. Namit Suri	Business Partner- Human Resource	9818821 111	namit.suri@stryker.c om	Gurugram
8	&	Metso	Sugandha Upadhyay	Assistant Manager-	9910806 553	sugandha.upadhyay@ metso.com	Gurugram	Interested in training
9								

## [SELF ASSESSMENT REPORT]



	Vaibhav Mishra			Human Resource				
10		DMRC	Mr. Lalit Sharma	Senior Controller	9911091557	lalit.sharma@dmrc.org	Delhi	Interested in training
11		IMT Cables	Mr. Naved	HR	9810109233		Gurugram	Interested in training
12		RICO Auto Industries	Mr. RS Yadav	Chief General Manager-HR	9810578755	rsyadav@ricoauto.com	Gurugram	Interested in training
13		SunBeam Auto Pvt. Ltd.	Mr. Pramod Tondon	GM			Gurugram	Interested in training
14		Flipkart	Mr. Sudhanshu Sharma	HR-North Region	9818181651	devidutt.s@flipkart.com	Gurugram	Interested in training
15		Bharat Seats	Anjali Sharma	HR	9853554482	anjali.sharma.bharatseats.net	Gurugram	Interested in training
16		SunBeam Auto Pvt. Ltd.	Mr. Vikas Sharma	Head of Human Resource	7060412232	vikas.sharma@sunbeamauto.com	Gurugram	Interested in training
17		Maruti	Mr. Rupam	HR	9167230690		Manesar	Interested in training
18		Ginni International Limited	Kedar Narayan Yadav	Management	91-1494-246069	plant@ginniint.com	Neemrana	Interested in training

## [SELF ASSESSMENT REPORT]



19	Arpit Gupta & Chirag Solanki	Parle (Parleproduct.com)	Jyoti Yadav	HR		(jyoti.yadav@parle.biz}	Neemrana	Interested in training
20		Daikin Air Conditioner	Pankaj Chaturvedi	HR		linkedin.com/in/pankaj-chaturvedi-18823341	Neemrana	Interested in training
21		Daikin Air Conditioner R&D	Pankaj Sharma	HR		linkedin.com/in/pankaj-sharma-05b70258	Neemrana	Interested in training
22		Y tech	Niranjan Yadav	HR	1494671020		Neemrana	Interested in training
23		Bosch	Sunil Jangar	Technical Trainer	9813203203	suniljangra04@hotmail.com	Neemrana	Interested in training
24		Dura line		HR	1494246200		Neemrana	Interested in training
25		Tops	Ajay Jha	HR-Head	9214386727		Neemrana	Interested in training
26		TS-tech	vikram singh yadav(HR)	HR-Head	7727031000	vikram_yadav@tssrindia.com	Neemrana	Interested in training
27		Keihin Fie	Kumar.S	HR-Head	9812301054	kumar.s@keihinfie.com	Bawal	Interested in training

## [SELF ASSESSMENT REPORT]



28		Rane NSK	krishan kant sharma	Process Head	9416065516		Bawal	Interested in training
29		Yushiro	GP latta	HR-Head	9636777307		Neemrana	Interested in training
30		MICROTEK Forging LTD.		Hr-Executive		www.bajaj motor.com (Send Inquiry)	Bawal	Interested in training
31	Shajade Alam & Mohit Pareek	Bhusan steel	Manish Kumar	Manager HR	-	mkumar@bhushansteel.com	Ghaziabad	Interested in training
32		Asis moulds india pvt ltd	MK JI	GM	8241423220	mkji@asis.co.kr	Greater Noida	Interested in training
33		Humboldt wedag	Avanish kr Gaur	Head HR	9873919101	avanish.gaur@khd.com	Faridabad	Interested in training
34		Simon India pvt ltd.	Sourendra Nath Banerjee	Deputy Manager	9643867270	sourendra.banerjee@adventz.com	Faridabad	Interested in training
35		Mothersons moulds and die casting	Pramod	Business Developer	-	-	Greater Noida	Interested in training
36		Rbm industries	Sandeep Bansal	HR Associate	9811218484	sandeep@rbmindustries.com	Faridabad	Interested in training
37			HAVELLS	Mr. R. K.	Sr. General	9799499	rohitash.kajala@have	Alwar

## [SELF ASSESSMENT REPORT]



			Kajala	Manager- HR	838	lls.com		training
38	Akhil Vijay & Hemant Bansal	METSO	Mr. Sanjay Sehgal	Sr. Manager- HR & IR Manufacturing India	8094019 207	sanjay.sehgal@metso .com	Alwar	Interested in training
39		HPAL Hariom Precision Alloys (P) Ltd.	Mr. I. P. Dua	Plant Head	9351496 322 144- 2702527/ 28	hpalcasting@gmail.c om	Alwar	Interested in training
40		INDO ALUSYS INDUSTRIES LTD.	Mr. Anil Gupta	Maintanance Head	8696919 501	N.A.	Bhiwadi	Interested in training
41		BKT TYRE	Mr. N. K. Joshi	HR Head	+91 (1493) 220 073	asia@bkt-tires.com bktbhiwadi@bkt- tires.com	Bhiwadi	Interested in training
42		Akhil Vijay	ROCA PARRYWAR E	Mr. Avdhesh K Mishra	General Manager- Operations	9829096 176	avdhesh.mishra@in.r oca.com	Alwar

## [SELF ASSESSMENT REPORT]



43	& Hemant Bansal	SYNERGY STEELS LTD.	Mr.Naveen Gang	Vice President (Works)	9351511 739	gang.naveen@synerg ysteels.com	Alwar	Interested in training
44	Contacts Referred by Mr. Kushwah EVP (P & Admin) , SANGA M INDIA LTD,	SANGAM GROUP	Mr. Vasisht	Head-HR	9811080 408	-	Bhilwara	Interested in training
45		SUDHIVA INDIA LTD	Mr. Pushpender Singh	HR	9636397 111	-	Sareri, Bhilwara	
46		NITIN SPINNERS LTD.	Mr. K.L. Pareekh	HR	9828548 023	-	Bhilwara	
47		BSL LTD.	Mr. Kopta Ji	HR	1482249 102	-	Bhilwara	
48		MAYUR LTD.	Mr. Brijech Joshi	HR	9414013 063	-	Jaipur Road, Gulabpura	
49		RELIENCE CHEMOTEX	Mr. Saxena Ji	HR	8003192 477	-	Udaipur	
50		STAR SPINNING MILL	Mr. P.J. Loddha	HR	7727002 541	-	Gangrar, Chittor	

## Consultancy

S.No.	Name of faculty	Name of organization to which consultancy provided	Nature of work	Amount
1	Dr. M.P.Singh	RAYFUEL ENERCON Pvt. Ltd.	Winch test	5000/-
2	Mr. Kuldeep Sharma	M/s balaji associates	Die design	5000/-
3	Dr. Bhivnesh Bhardwaj	R tekhno solution	Manufacturing	25000/-
4	Mr. Satyendra Kumar	Bhagwati drug company	Chemical testing	Nil
5	Mrs. Palak Jindal	Jindal tech infrastructure pvt ltd.	Structure construction	Nil
6	Md. Inzamam Ul Haq	Unison machinery pvt ltd.	Production	Nil

### 2.2.5 Initiatives related to industry internship/summer training (15)

- Rajasthan Technical University provides minimum of 6 weeks of industrial training in the form of summer internship after their sixth semester during its 4 year curriculum.
- Students are also encouraged to participate in industrial orientation programme from time to time.
- The process of allotment of summer internships is as follows:
  - ❖ Initially Department issue a letter for summer internship for every student.
  - ❖ Students will show this letter to respective company/organization from where they want to pursue their training programme.
  - ❖ Company will acknowledge to college (department) letter of summer training.
  - ❖ Once the company approval comes, department will take review on that particular company profile and if it is found appropriate for training then only students are allowed to pursue their training from that company.
  - ❖ After that, department issue approval letter for summer training.



- ❖ After completion of training, company issued a certificate or evaluation letter.
- ❖ Students have to submit their Xerox copy of summer training certificate.
- ❖ A presentation followed by viva-voce is taken on their summer training in next semester on which they have to submit a report.
- ❖ Final evaluation will be done and marks will be given for summer internship programme.

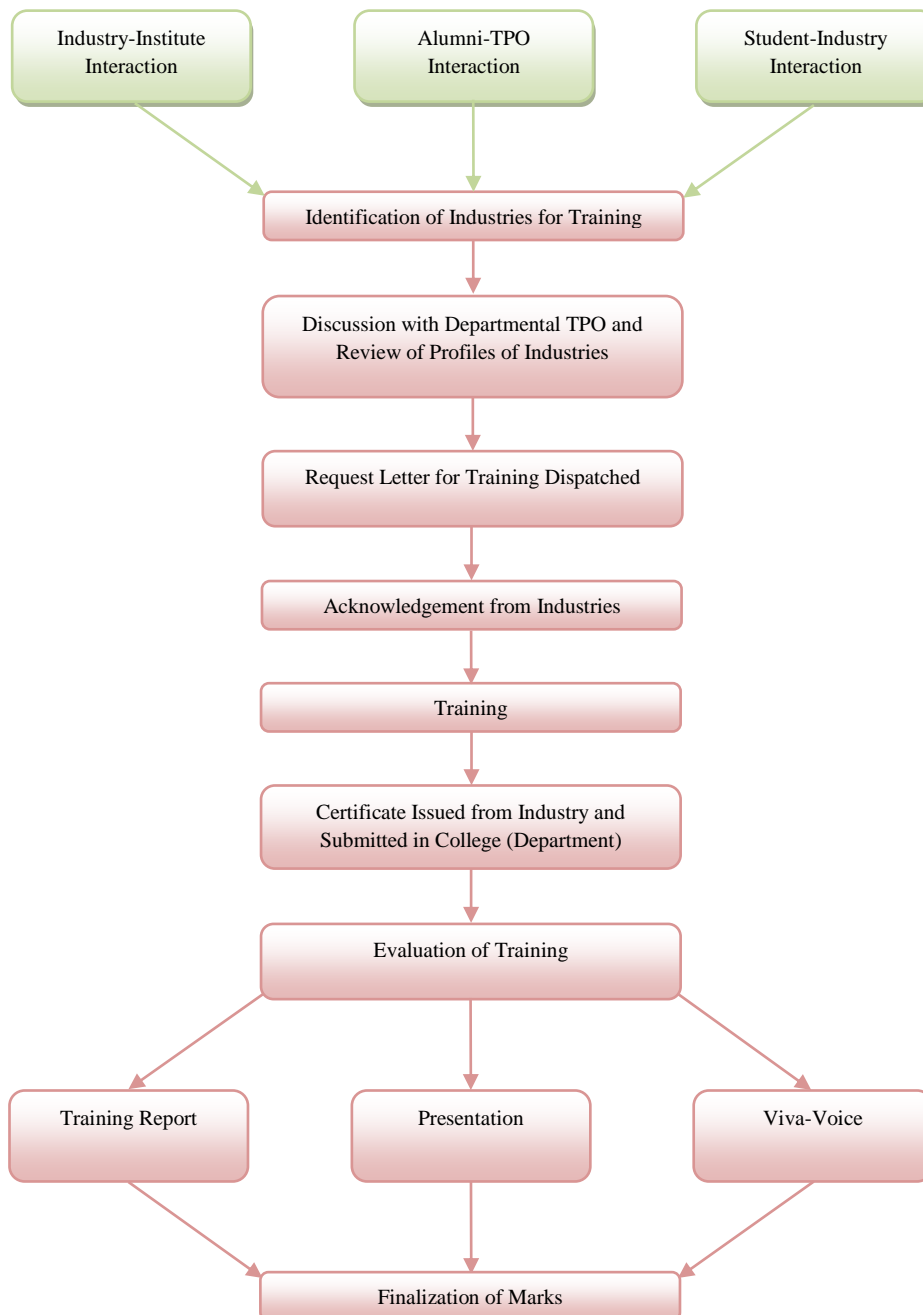

**Figure 2.5 Process of Evaluation of Training**

# [SELF ASSESSMENT REPORT]



Ref: JECRC /PT /2015

Date: 16-05-2015

To  
HR Manager  
KEC Int. Ltd.  
Jaipur

## Subject – Request for Summer Training / Internship

Mr / Ms. PRITISH CHANDHOK student of Jaipur Engineering College and Research Centre (JECRC) Jaipur, III year B. Tech ( Mechanical Engineering) is approaching you for Summer Training during May-July 2015. This training will help him to get exposed to the field conditions and gain experience in real working environment.

JECRC is approved by All India Council for Technical Education and affiliated to Rajasthan Technical University. We shall feel highly obliged if you could impart training to him/her.

It is requested that your organisation may kindly provide Summer Training. Please feel free to contact us for clarification, if any. The college would be grateful for your cooperation.

Training & Placement Coordinator



Jaipur Engineering College and Research Centre  
Approved by AICTE & Affiliated to R11  
JECRC Campus, Shri Ram Ki Nangal,  
Via Sitapura RICO, Opp. EPIP Gate, Tonk Road, Jaipur 302 022  
t: 0141 2770120, 2770232 f: 0141 2770803 e: info@jecrcmail.com

# [SELF ASSESSMENT REPORT]



## Training detail table

<b>Jaipur Engineering College &amp; Research Centre, Jaipur</b>			
<b>Department Of Mechanical Engineering-Practical Training-(2016-17)</b>			
<b>R.N o.</b>	<b>Name Of Students</b> ↓	<b>Training Destination</b>	<b>Outcomes</b>
1	Aadil Ahmed Farooqui	Bosch Jaipur	D. Planning, Maintenance
2	Abhimanyu Singh Bhati	Thermal Super Power Plant, Kota	Power Generation
3	Abhisek Bharadwaj	Tata Eicher Engine, Alwer	Manufacturing (Assembly)
4	Abhishek Swami	Super Thermal Power, Surat	Manufacturing
5	Aditya Agarwal	Reliance Industries Ltd, Jamnagar	Design, Quality Control Maintenance
6	Akansh Agarwal	Ashok Leyland, Alwar	Maintenance, Manufacturing
7	Akash Garg	Dholpur Combined Cycle Power Plant	Planning , Quality
8	Akash Jain	Jit Process ,Alwar	Machining Process
9	Akhil Kumar	Diesel Shed, Phulera	Maintenance
10	Akshat Tiwari	Bosch Jaipur	First Pass Yield Imp/Quality
11	Akshay Bhardwaj	National Engineering Industries Ltd, Jaipur	Manufacturing, Quality Control
12	Akshay Kirti Sharma	Minda Industries Ltd	Manufacturing, Planning
13	Akshay Kumar Soni	Ultratech Cement Ltd	Planning , Quality, Control, Maintenance
14	Aman Gupta	Ashok Leyland, Alwar	Maintenance, Manufacturing
15	Aman Vyas	Nuclear Power Corporation of Industries	Production of Obclevlty
16	Amit Modi	Jit Process ,Alwar	Machining Process
17	Aniket Sharma	Jbm Ltd, Gurgaon	Maintenance, Manufacturing
18	Anish Jain	Heavy Water Plant, Kota	Heavy Power Production
19	Anjani Kumar Mundhara	Rajasthan Surico(P) Ltd, Napaser	Manufacturing
20	Ankit Bhardwaj	Nei-Nbc Beawar	Analysis Of Bearing
21	Anshul Jain	Maruti Suzuki India Ltd. Gurgaon	Design, Quality Maintenance
22	Anshul Khandelwal	Kec Int. Ltd, Jaipur	Production Process
23	Anshuman Sisodia	Shree Cements, Beawar	Planning, Manufacturing, Maintenance
24	Anuj Bhandari	Hindustan Zinc Ltd, Dariba	Process, Project
25	Anuj Tiwari	Indian Railway, Ajmer	Maintenance,
26	Anurag Verma	Bosch Jaipur	Planning, Market
27	Arnim Vijay	Ina Bearings India (Schaeffles Group)	Disciplinary Actions

## [SELF ASSESSMENT REPORT]



28	Arun Yadav	Maruti Suzuki India Ltd.	Chance The Theory Knowledge
29	Ashesh Bansal	Dholpur Combined Cycle Power Plant	Get, Production, Power Generation
30	Ashish Kumar Choudhary	Hindustan Copper Ltd, Khetri	Manufacturing
31	Ashutosh Kumar	Riw Auto Industuies, Dharuhera	Manufacturing
32	Ashwini Kumar Tripathi	Diesel Locomotice Works	Manufacturing
33	Asutosh Jain	Hec Npcil	Design, Maintenance, Power Generation
34	Atul Chaudhary	Ashok Leyland, Alwar	Front And Real Acle And Chasis Assembly
35	Avadhesh Kumar Sharma	Ashok Leyland, Alwar	Front And Real Acle And Chasis Assembly
36	Ayan Dutta	Tata Technoloyies, Pune	Topograhoy
37	Ayush Khandelwal	Tata Eicher Engine, Alwer	Assembly Department
38	Bhanu Pratap Singh	Diesel Shed, Phulera	Maintence
39	Chetan Prakash Saini	Tmtl Eicher Engines Ltd	Assembly Line
40	Deepanshu Sharma	Ashok Leyland, Alwar	Assembly
41	Deepender Singh Rathore	Diesel Shed, Phulera	Maintence
42	Dharmesh Kumar Sharma	Kec, Jaipur	Fabriation
43	Dheeraj Agarwal	Ashok Leyland, Alwar	Working Of Hydrolic Pumps
44	Divyansh Bhatnagar	Iit Guwahati,Guwahati	Eco Friendly Cutting & Wids
45	Ekant Singh	Hec,Ranchi,Eicher	Planning,Manufacturing
46	Gajendra Kumar Teli	Kec,Jhotwara,Jaipur	Galavanizing
47	Ganesh Kumar Sah	Net,Jhotwara,Jaipur	Manufacturing
48	Gaurav Gadodia	Net,Jhotwara,Jaipur	Manufacturing
49	Gaurav Prajapati	Ntpc,Antarbaran(Raj)	Study Of Turbine
50	Gaurav Sahu	Kec Int. Ltd	Galavanizing Department
51	Harsh Agarwal	Ashok Leyland, Lt	Manufacturing And Quality Control
52	Harsh Yadav	North Western Railways,Bikaner	Fabrication
53	Harshita Garg	Gail Ajmer	Estimated Repair Factor
54	Harshvardhan Arya	Bosch Ltd,Jaipur	Desigh And Maintainance
55	Hemant Kumar Patidar	Kalisindh Thermal Power Plant	Design &Function
56	Himanshu Nagar	Chhabra Thermal Power Plant	Power Generation
57	Himanshu Sharma	Bosch India Ltd.Jaipur Plant	Design And Rootcause Finding
58	Jitendra Choudhary	Jit Processors	Manufacturing

## [SELF ASSESSMENT REPORT]



59	Jitendra Kumar Sain	Hmt Ajmer	Casting
60	Kapil Sharma	Jit Procerssors	Manufacturing
61	Keshav Goyal	Hmt	Manufacturing
62	Lekhraj Gakkhar	Ashok Leyland Ltd.	Chassic Assembly
63	Lokesh	Honda Cars India Limited	Quality Control
64	Manish Arora	Kec International Ltd.	Galvanizing Deptt
65	Mohit Yadav	Eicher Engines Ltd	Assembly Line
66	Mragank Ohja	Bosch Jap	Plant Quality Automasive
67	Mridul Agrawal	Hmt,Ajmer	Manufacturing &Assembly
68	Mukesh Kumar	Kec International Ltd.	Galvanising Deptt
69	Mushtafa Kohri	North Western Railways	Maintanance
70	Naman Jain	Hmt	Manufacturing
71	Namit Kumar Tiwari	Nbc Jaipur	Manufacturing &Assembly
72	Namit Misra	, Nbc Jaipur	Manufacturing
73	Naveen Kumar Sahu	Bharat Buagon Company Ltd, Bihar	Manufacturing, Assembly
74	Nishant Bhargava	National Engnieering Industries Ltd, Jaipur	Manufacturing
75	Parth Mittal	Adani Thermal Power Rajathan	Power Production
76	Pawan Kanoongo	National Engnieering Industries Ltd, Jaipur	Manufacturing
77	Pawan Kumar	Bosch Ltd,Jaipur	Maintanance
78	Prabal Kumar Jain	Shree Cements, Beawar	Welding And
79	Prakash Chandra Jyani	Aarmom Tech. Pv.T	Designing And Inspection
80	Prakash Patel	Aarmom Tech. Pv.T	Designing And Inspection
81	Pramod Kumar	Bharat Wagon And Engg. Ltd	Manufacturing
82	Prateek Mittal	Tera Reseach Institute Ltd	Manufacturing
83	Rahul Bhatnagar	Adrde, Agra	Welding
84	Rahul Mangal	Sumrise Containers Ltd	Manufacturing
86	Rajchander Jain	Kec Ltd, Jaipur	Fabrication
87	Ramnik Kaul	Roca Bathroom Produit Pvt. Ltd	Bathroom Maintacnce
88	Raunak Sharma	National Engnieering Industries Ltd, Jaipur	Manufacturing
89	Raushan Kumar	Bharat Wagon And Engg. Ltd	Practical Field Work
90	Rifatullah Khan	Hindusthan Zine Ltd	Maintanance
91	Rishabh Gupta	Maruti Suzuki Ltd	Quality Control
92	Rohan Jain	Roca Bathroom Produit Pvt. Ltd	Bathroom Maintacnce
93	Rohit Kumar	National Engnieering Industries Ltd, Jaipur	Production Process

## [SELF ASSESSMENT REPORT]



94	Rohit Mehta	Satyam Auto Component Pvt. Ltd	Quality Control
95	Ronak Jain	Action Construcation Equipment Ltd	Assembly, Design, Quality Control
96	Sachin Parashar	Yamaha Indiiia Moter Pvt. Ltd	Manufactring
97	Samoli Kumar	Bharat Wagon And Engg. Ltd	Production And Manufacturing
98	Santosh Kumar	Bharat Wagon And Engg. Ltd	Production And Manufacturing
99	Sanwar Lal Gurjar	Hmt,Ajmer	Manufactring, Assembly
100	Saransh Hari	Vita Cera Services Ltd	Android Based Apliaction
101	Satya Prabhat	Premium Molding And Pressing	Production
102	Saurabh Kumar Singh	Yamaha Indiiia Moter Pvt. Ltd	Manufactring
103	Sawan Agarwal	Ajmer Diesel And Locomotive	Inspection And Maintanace
104	Shashi Kumar	Bharat Wagon And Engg. Ltd	Inspection
105	Shubham Goyal	Nei, Jaipur	Manufactring
106	Shubham Gupta	Nei, Jaipur	Manufactring
107	Shubham Sharma	Larson And Turbo	Produvtion
108	Sourabh Gupta	Ntpc,Antarbaran(Raj)	Study Of Turbine
109	Sudhir Kumar	Kec, Jaipur	Tubrication
110	Sumit Kumar Pachouri	Mahindra And Mahindra Tractors	Lubrication And Assembling
111	Surender	Jindal Station Steel, Hisar	Manufactring
112	Surendra Joshi	Jaypee Sidhi Cement M.P	Manufactring
114	Vinayak Gaur	North Western Railway Bikaner	Maintanance
115	Vishal Yadav	North Western Railway Bikaner	Maintanance
116	Vishwas Singh	Minda Industries Ltd	Manufactring
117	Yashwant Kumar Nama	Nei (Nbc)	Manufactring
118	Dushyant Pareek	Bosch Ltd,Jaipur	Maintanance
119	Naresh Saini	National Engineeing Industries Ltd, Jaipur	Manufactring
120	Yashasvi Bareth	Rajasthan Roadways	Observation And Learing
121	Hitesh Chouhan	Loco And Diesel Workshop Ajmer	Maintanance
122	Prakash Udeniya	Loco And Diesel Workshop Ajmer	Maintanance
123	Deepak Kumar	Coach Care Complex Jaipur	Maintanance

## [SELF ASSESSMENT REPORT]



124	Wasim Akhtar	Iocl, Barauni Bihar	Maintenance (Workshop)
125	Vikash Kumar Sinha	Iocl, Barauni Bihar	Maintenance (Workshop)
126	Dhanraj	Nwr Carriage And Wagon Workshop Ajmer	POH
127	Nitish Kumar	Iocl, Barauni Bihar	Maintenance (Workshop)
128	Jasvinder Singh	Kecil, Jaipur	Fabrication
129	Prakhar Agrawal	Nei Jaipur	Manufacturing
130	Shivam Gandhi	Loco And Wagon Workshop Ajmer	Maintenance
131	Gaurav Gupta	Eicher Engines Ltd	Maintenance
132	Garvit Jain	Bhel Bhopal	Manufacturing
133	Santosh Rawat	Nei Jaipur	Manufacturing
134	Shubham Gupta	Ntpc, Antarbaran(Raj)	Study of Turbine
135	Aaditya Bishnoi	Swaraj Mahindra Mohali	Maintenance, Assembly, Creating Sops
136	Ashish Sharma	Climatech Aircon Eng. Pvt. Ltd	Installation , Service
137	Chetan Prajapati	Climatech Aircon Eng. Pvt. Ltd	Installation , Service
138	Daljeet Singh	Kec, Ltd, Jaipur	Fabrication, Maintenance
139	Devesh Chundawat	Morani Hyunde	Maintenance
140	Harish	Suratgarh Thermal Power Plant	Power Generation
141	Irphan Khan Pathan	Rajasthan Agro Industrial Ltd	Assembling
142	Mrinal Pandya	J.K Tyres & Industrial Ltd	Manufacturing, Maintenance
143	Pavan Kumar Sharma	Jindal Station Steel, Hisar	Manufacturing
144	Pramod Kumar	Jindal Station Steel, Hisar	Manufacturing
145	Rahul Aswal	Nbc (Nei)	Manufacturing
146	Rakshit Trivedi	Rshm Thermal Power Plant	Power Generation
147	Shailendar Patidar	Nbc (Nei)	Manufacturing
148	Shubham Arora	Nwr Carriage And Wagon Workshop Ajmer	POH
149	Sourabh Dashora	Ashok Leyland Pvt. Ltd Utrakhnad	Testing Of Engine
150	Subham Vaishnav	Clenatech Aircen Eng. Pvt. Ltd	Installation , Service

# [SELF ASSESSMENT REPORT]



Jaipur Engineering College & Research Centre, Jaipur			
Department Of Mechanical Engineering-Practical Training-(2017-18)			
R.No.	Name Of Students ↓	Training Destination	Outcomes
1	Aditya Malik	Nissan,Sbft Design	Design
2	Aishwerya Johari	Loco Diesel And Wagon Workshop N.W.R.	Maintenance
3	Akhil Singhal	Cimmco Ltd.	Planning And Manufacturing
4	Akshay Chaturvedi	Carriage Railway	Maintenance
5	Akshay Galav	K.S.T.P.S	Steam Turbine
6	Anirudh Jain	Honda	Ferrous
7	Anirudh Kumar Jain	Jpr Rlway Shree Cement	Manufacturing
8	Ankit Malav	K.S.T.P.S	Steam Turbine
9	Ankur Goyal	Shree Cement	Maintenance
10	Anmol Rajawat	Nbc Jaipur	Ball Bearing
11	Anshul Jain	Chhabra Thermal Power	Thermal Division
12	Anuj Yadav	Nbc Jaipur	Ball Bearing
13	Anurag Bansal	Coachcare Complex	Maintenance
14	Arpit Agarwal	Bosch,Bangluru	Automobile Technology
15	Arpit Akar	Indian Railways	Maintenance
16	Arpit Gupta	Bosch Ltd.	Automobile Technology
17	Arpit Natani	Rapp Rawatbhata	Maintenance
18	Arpit Sharma	K.S.T.P.S	Steam Turbine
19	Ashish Kumar	K.S.T.P.S	Steam Turbine
20	Ashish Kumar Gupta	Railway Kota	Maintenance
22	Ashok Sinwar	Bosch, Ajmer Railway	Maintenance
23	Ashutosh Dhyani	Gmax Auto Limited	Mold Assembly
24	Ayush Kumar Gupta	Jaipur Railways	Loco
25	Bharat Agarwal	Nbc Jaipur	Manufacturing
26	Bhudev Prasad Sharma	K.S.T.P.S	Power Generation
27	Chandra Mohan Sharma	Fev Pune, India	Mechanical Setup
28	Chandra Pratap	Ntpc Dadri	Power Generation
29	Chirag Solanki	Fev Pune, India	Project Management
30	Deepesh Mittal	Jbm, Gurugram	Quality Assurance
31	Devesh Purohit	Nbc Jaipur	Maintenance
32	Dhruv Khandelwal	Nbc Jaipur	Manufacturing



## [SELF ASSESSMENT REPORT]



33	Dhruv Laddha	Wonder Cement	Mechanical
34	Dilip Jajoo	B.M. Techno Machines	Mfg. Dept.
35	Dinesh Kumar Jain	Ajmer Railway, Jbm Group Gurgaon	Maintenance
36	Dushyant Jha	Ashok Leyland	Chassis Assembly
37	Gagan Kumar Jindal	Denso India Pvt. Ltd.	Assembly Line
38	Gaurav Pareek	Nbc	Tapper Bearing Assembly
39	Gaurav Vaishnav	Nbc Jaipur	Tapper Bearing Assembly
40	Govind Kumar Poddar	Bharat Wagon	Manufacturing
41	Govind Vyas	Mahindra And Mhindra	Aintenance Process In Assembly Line
42	Harichand Goswami	Dccps	Power Generation
43	Himanshu Guneshwar	Ashok Leyand	Spqa
44	Himanshu Paliwal	K.S.T.P.S	Power Generation
45	Himanshu Rai	Dlw	General Department
46	Hitesh Arora	Honda	Ferrous
47	Jai Kishan Soni	Sksup Ltd.	Manufactring
48	Javed Khan	K.S.T.P.S	Power Generation
49	Jitesh Kumar	Dccps	Power Generation
50	Kalpesh Patidar	R V U N L	Power Generation
51	Kana Ram Nitharwal	Jcb	Installation of Salt Conveyor
52	Kapil Tejwani	Nbc Jaipur	Maintenance
53	Keshav Gandhi	Diesel Loco And Wagon Workshop,	Maintenance
54	Khushal Patodia	Eicher Engines	Maintenance
55	Kuldeep Kushwah	Loco And Waon Workshop Ajmer	Maintenance
56	Kuldeep Saini	Nbc Jaipur	Maintenance
57	Lakshya Joshi	Hindustan Aeronautics Ltd	Mfg. Dept.
58	Lileshwar Singh Rawat	Mp Birla Cement	Production
59	Lincoln Gori	Barc, Eicher	Reactor Safety Division, Engineering
60	Mahak Bhatt	K.S.T.P.S	Power Generation
61	Mahak Goyal	Shree Cement	Manufacturing
62	Mayank Sharma	Land T	Automation
63	Md Quamre Alam	Ioel	Mechanical Department
64	Mohit Saini	Danish Pvt Ltd	Manufacturing
65	Mudit Garg	Fev Pune, India	Mechanical Setup

## [SELF ASSESSMENT REPORT]



66	Navneet Kumar	Iocl	Mechanical Department
67	Nayan Singh	Nbc Jaipur	Maintenance
68	Neel Mehta	Iocl	Mechanical Department
69	Nitin Soni	Nbc (Nei)	Maintenance
70	Om Prakash Yadav	Pradeep Transcore Pvt.	Production
71	Pallav Pandey	K.S.T.P.S	Power Generation
72	Piyush Kataria	Force Motors	Automobile Workshop
73	Prashant Prajapati	Nwr, Coach Care Complex	Bogie Maintenance
75	Rachit Sharma	Eicher, Alwar	Maintenance
76	Raghuveer Singh Hada	Kstps	Production
77	Rahul Gahlot	Dunac Tata Motors	Inventory
78	Rahul Gupta	Eicher, Alwar	Maintenance
79	Rahul Gupta	Birla Cimmco	Maintenance
80	Ram Kumar Prajapati	Nwr Abr	Maintenance
81	Rishabh Bhardwaj	Ginni	Production
82	Rohit Kumar	Nwr Abr	Maintenance
83	Ronak Jain	Force Motors	Service
84	Sandeep Singh	Nwr Abr	Maintenance
85	Santosh Sharma	Nwr Abr	Maintenance
86	Satya Prakash Arya	Fev India	Laboratory
87	Satyam Jain	Caparo Maruti	Production
88	Saurabh Mangal	Shree Cement	Production
89	Shahjade Alam	Dmrc	Am/Rs
90	Shashank Bhandari	Wonder Cement	Production
91	Shivam Gupta	Kota Super Thermal Power Station	Coal Handling
92	Shivoham Shrivastava	Nbc,Jaipur	Maintenance
93	Shobhit Yadav	Eicher Engines	Maintenance
94	Shubham Garg	Shriram Piston & Rings Ltd. Bhiwadi	Production
95	Shubham Heda	Shree Cement	Production and Maintenance
96	Shubham Jain	Eicher Engines	Maintenance
97	Shubham Khandelwal	Nei Ltd	Manufacturing
98	Shubham Rathi	Rgtpp	Production
99	Shubham Shukla	Mahi Hydel Power Station	Maintenance
101	Subham Choudhary	Shree Cement	Manufacturing
102	Sudama Kumar	Nbc	Production

## [SELF ASSESSMENT REPORT]



103	Sumit Khurana	Nbc,Jaipur	Production
104	Sunil Kumar Verma	Nwr Abr	Maintenance
105	Suresh Choudhary	Hrhe	Manufacturing
106	Tusshar Joshi	Mahi Hydel Power Station	Maintenance
107	Vaibhav Kumar Garg	Kota Super Thermal Power Station	Coal Handling
108	Vaibhav Vyas	Hrhe	Manufacturing
109	Varun Agarwal	Jbm	Quality
110	Vedant Singhal	Kota Super Thermal Power Station	Production
111	Vidyabhushan Kumar	Bosch	Training Centre
112	Vijesh Kumar Darji	Baba Automobile	Training Centre
113	Vinod Kumar Patel	Iocl	Maintenance
114	Vishal Kumar Bansal	Kota Super Thermal Power Station	Production
115	Vishal Sharma	Shriram Piston & Rings Ltd.	Production
116	Vishvender Kumar	Manufacturing Proseses Of Ball Bearing	Manufacturing
117	Vishvendra Singh	Dccpp	Maintenance
118	Vivek Sharma	Tata Motors	Service
119	Vivek Soni	Nbc	Taper Roller Beareing
120	Yash Kumar Gupta	Nbc	Ball Department
121	Yash Verma	Nbc,Jaipur	Production
123	Akshay Darshan Singh	Cadd Center	Product Design
124	Vaibhav Mishra	Delta Star Rewari	Production
125	Shubhank Sharma	L&T Vadodra	Designing
126	Saurashtra Kumar	Bosch	Training Centre
127	Akhil Kuldeep	Rajasthan Atomic Power Station	Nuclear Training Centre
128	Abhishek Kumar	Bharat Wagon & Engg. Ltd	Manufacturing
129	Aijaj Khan	Jaipur Dairy	Production
130	Akshay Pal	Ntpc	Power Production
131	Anish Joseph	Vikram Cement	Production
132	Ankit Meena	Kstps	Production
133	Ankur Kumar Pareek	Shree Cement	Production
134	Girish Khandelwal	Eicher Engines	Testing
135	Gurjar Shrawan Kumar Jasvantbhai	Jaipur Dairy	Production

## [SELF ASSESSMENT REPORT]



136	Hemraj Jangir	Tata Motors	Srevice
137	Himanshu Dubey	Apollo Tyre	Manufacturing
138	Jitendra Sharma	Cummins Service Center	Maintenance
140	Nirankar Singh	Nbc	Production
142	Pushpendra Kumar Jangid	Jaipur Dairy	Production
144	Raushan Kumar	Bharat Wagon & Engg. Ltd	Production
145	Sagir Ahmad	New Swadeshi Sugar Mill	Production
146	Samaksh Jha	Tata Motors	Maintenance
147	Satveer	Suratgarh Thermal Power Plant	Production
148	Shivam Rawat	Jaipur Dairy	Production
149	Vijay Kumar Sharma	Maruti Suzuki	Maintenance
150	Dhananjay Ku. Yadav	Apollo Tyre	Manufacturing
151	Yash Sharma	Shree Cement	Power Production



CRITERION 03	Course Outcomes (CO's) & Program Outcomes (PO's)	120
--------------	--	-----

### 3. COURSE OUTCOMES AND PROGRAM OUTCOMES (120)

#### 3.1. Establish the correlation between the courses and the Program Outcomes (PO's) and Program Specific Outcomes (PSO's)

##### Program Outcomes

- 1. Engineering knowledge:** Apply the knowledge of mathematics, science, engineering fundamentals, and an engineering specialization to the solution of complex engineering problems in Mechanical Engineering.
- 2. Problem analysis:** Identify, formulate, research literature, and analyze complex Mechanical Engineering problems reaching substantiated conclusions using first principles of mathematics, natural sciences, and engineering sciences.
- 3. Design/development of solutions:** Design solutions for complex Mechanical Engineering problems and design system components or processes that meet the specified needs with appropriate consideration for the public health and safety, and the cultural, societal, and environmental considerations.
- 4. Conduct investigations of complex problems:** Use research-based knowledge and research methods including design of experiments, analysis and interpretation of data, and synthesis of the information to provide valid conclusions in Mechanical Engineering.
- 5. Modern tool usage:** Create, select, and apply appropriate techniques, resources, and modern engineering and IT tools including prediction and modeling to complex Mechanical Engineering activities with an understanding of the limitations.
- 6. The engineer and society:** Apply reasoning informed by the contextual knowledge to assess societal, health, safety, legal and cultural issues and the consequent responsibilities relevant to the professional Mechanical engineering practice.
- 7. Environment and sustainability:** Understand the impact of the professional Mechanical Engineering solutions in societal and environmental contexts, and demonstrate the knowledge of, and need for sustainable development.
- 8. Ethics:** Apply ethical principles and commit to professional ethics and responsibilities and norms of the Mechanical Engineering practice.
- 9. Individual and team work:** Function effectively as an individual, and as a member or leader in diverse teams, and in multidisciplinary settings in Mechanical Engineering.
- 10. Communication:** Communicate effectively on complex Mechanical Engineering activities with the engineering community and with society at large, such as, being able to comprehend and write effective reports and design documentation, make effective presentations, and give and receive clear instructions.
- 11. Project management and finance:** Demonstrate knowledge and understanding of the Mechanical Engineering and management principles and apply these to one's own work, as a member and leader in a team, to manage projects and in multidisciplinary environments.



12. **Life-long learning:** Recognize the need for, and have the preparation and ability to engage in independent and life-long learning in the broadest context of technological change in Mechanical Engineering.

**PSO-Program Specific outcomes**

1. **PSO1.** Apply the knowledge of material science, manufacturing and design to implement the various concepts of vehicle mechanics.
2. **PSO2.** Apply the knowledge of 3D printing technology in design and development of prototypes.

**3.1.1 Course Outcomes (COs) (05)**

After successful completion of this course student will be able.....

**1<sup>st</sup> Semester Subjects**

**Subject: PRACTICAL GEOMETRY**

**Code: 109**

CO-1	To explain objects in First and third angle with different scale.
CO-2	To illustrate basic 3-dobjects in 2-d drawing.

**2<sup>nd</sup> Semester Subjects**

**Subject: Engineering Mechanics**

**Code: 205**

CO-1	Students will be able to describe fundamental laws of forces, FBD and virtual work.
CO-2	Students will be able to identify problem associated with Centre of gravity and Moment of Inertia.
CO-3	Students will be able to understand the basic concept of stress and strain.
CO-4	To able to describe the laws of motion, kinematics of rigid bodies,work,energy and power.

**3<sup>rd</sup> Semester Subjects**

**Subject:Mechanics Of Solids**

**Code: 3ME1A**

CO-1	The student will be able to classify stress /strain in structural members subjected to different types loading condition.
CO-2	The students will be able to construct SF & BM for various types of loads/beams.
CO-3	The students will be able to solve problems on torsion member ,structural member and pressure vessels



**4<sup>th</sup> Semester Subjects**

**Subject:** Kinematics of Machines

**Code:** 4ME1A

CO-1	To discuss the concept of mechanism in different type of machine elements.
CO-2	To Interpret various mechanism and applications.
CO-3	To apply the concepts of power transmission
CO-4	To analyze cam profile for a given input/out put motion.

**5<sup>th</sup> Semester Subjects**

**Subject:** Heat Transfer

**Code:** 5ME1A

CO-1	To calculate conductive heat transfer rate
CO-2	To analyze the basic concept of convection and vaporization phenomena
CO-3	To chose appropriate heat exchanger according to application
CO-4	To discuss the concept of radiation and impact of energy systems on the global environment.

**6<sup>th</sup> Semester Subjects**

**Subject:** Design of Machine Elements - II

**Code:** 6ME1A

CO-1	To determine the finite and infinite life of mechanical components due to fluctuating loads.
CO-2	To analyse the various automobile parts under different service conditions
CO-3	To design the different types of gears due to gear forces.
CO-4	To identify the different types of bearing under various loads.

**7<sup>th</sup> Semester Subjects**

**Subject:** Finite Element Methods

**Code:** 7ME1A

CO-1	To interpret the philosophy behind principles, design and modeling considerations in using finite element analysis.
CO-2	To apply the concept of direct equilibrium method and potential energy method for structural mechanics problems
CO-3	To Analyze 1-D Heat transfer, Solid mechanics, fluid Mechanics problems using different integration and vibrational formulation.



**8<sup>th</sup> Semester Subjects**

**Subject:** Computer Integrated Manufacturing Systems

**Code:** 8ME1A

CO-1	To identify the main elements in Computer Integrated Manufacturing Systems.
CO-2	To apply the knowledge of Computer Aided Process Planning (CAPP), features, Group Technology and data exchange in Manufacturing Processes.
CO-3	To analyse the process product models with CAM tools and CNC machines with Collaborative Engineering

*Table B.3.1.1*

**3.1.2. CO-PO matrices of courses selected in 3.1.1 (six matrices to be mentioned; one per semester from 3rd to 8th semester) (05)**

**3<sup>th</sup> Semester Subjects**

**Subject:** Mechanics Of Solids

**Code:** 3ME1A

Subject Code	COs	Program Outcomes (POs)											
		PO-1	PO-2	PO-3	PO-4	PO-5	PO-6	PO-7	PO-8	PO-9	PO-10	PO-11	PO-12
3ME1A	CO-1	3	2								2		2
	CO-2	3	1										
	CO-3	3											

**4<sup>th</sup> Semester Subjects**

**Subject:** Kinematics of Machines

**Code:** 4ME1A

Subject Code	COs	Program Outcomes (POs)											
		PO-1	PO-2	PO-3	PO-4	PO-5	PO-6	PO-7	PO-8	PO-9	PO-10	PO-11	PO-12
4ME1A	CO-1	3	3	2									
	CO-2	3	3	3									
	CO-3	3	3										
	CO-4	3	3	3	3								

**5<sup>th</sup> Semester Subjects**

**Subject:** Heat Transfer

**Code:** 5ME1A

Subject Code	COs	Program Outcomes (POs)											
		PO-1	PO-2	PO-3	PO-4	PO-5	PO-6	PO-7	PO-8	PO-9	PO-10	PO-11	PO-12
5ME1A	CO-1	3											2
	CO-2	3	2					2					3
	CO-3	3											2
	CO-4	3	3					3					3



# [SELF ASSESSMENT REPORT]



## 6<sup>th</sup> Semester Subjects

**Subject:** Design of Machine Elements - II

**Code:** 6ME1A

Subject Code	COs	Program Outcomes (POs)											
		PO-1	PO-2	PO-3	PO-4	PO-5	PO-6	PO-7	PO-8	PO-9	PO-10	PO-11	PO-12
6ME1A	CO-1	3	2								2		
	CO-2	3									3		
	CO-3	3	3	3	1						3	2	
	CO-4	3	2	3	2						3	2	

## 7<sup>th</sup> Semester Subjects

**Subject:** Finite Element Method

**Code:** 7ME1A

Subject Code	COs	Program Outcomes (POs)											
		PO-1	PO-2	PO-3	PO-4	PO-5	PO-6	PO-7	PO-8	PO-9	PO-10	PO-11	PO-12
7ME1A	CO-1	2	2		3	3							
	CO-2	2	3	3	3	3					3		
	CO-3	3	3	3	3	3					3		

## 8<sup>th</sup> Semester Subjects

**Subject:** Computer Integrated Manufacturing Systems

**Code:** 8ME1A

Subject Code	COs	Program Outcomes (POs)											
		PO-1	PO-2	PO-3	PO-4	PO-5	PO-6	PO-7	PO-8	PO-9	PO-10	PO-11	PO-12
8ME1A	CO-1	3		2		3					2	3	
	CO-2	3		2		3					2	3	
	CO-3	3		2	2	3					2	3	

*Table B.3.1.2a*

**MAPPING OF PSO's –CO's**

## 3<sup>rd</sup> Semester Subjects

**Subject:** Mechanics Of Solids

**Code:** 3ME1A

Subject Code	COs	Program Specific Outcomes (PSOs)	
		PSO-1	PSO-2
3ME1A	CO-1	1	
	CO-2		
	CO-3	2	



**4<sup>th</sup> Semester Subjects**

**Subject:** Kinematics of Machines

**Code:** 4ME1A

Subject Code	COs	Program Specific Outcomes (PSOs)	
		PSO-1	PSO-2
4ME1A	CO-1	3	1
	CO-2	2	1
	CO-3	3	
	CO-4	2	1

**5<sup>th</sup> Semester Subjects**

**Subject:** Heat Transfer

**Code:** 5ME1A

Subject Code	COs	Program Specific Outcomes (PSOs)	
		PSO-1	PSO-2
5ME1A	CO-1	3	
	CO-2		3
	CO-3		
	CO-4	3	

**6<sup>th</sup> Semester Subjects**

**Subject:** Design of Machine Elements - II

**Code:** 6ME1A

Subject Code	COs	Program Specific Outcomes (PSOs)	
		PSO-1	PSO-2
6ME1A	CO-1	3	
	CO-2	3	
	CO-3	3	
	CO-4	3	

**7<sup>th</sup> Semester Subjects**

**Subject:** Finite Element Methods

**Code:** 7ME1A

Subject Code	COs	Program Specific Outcomes (PSOs)	
		PSO-1	PSO-2
7ME1A	CO-1	3	3
	CO-2	3	3
	CO-3	3	3



**8<sup>th</sup> Semester Subjects**

**Subject:** Computer Integrated Manufacturing Systems

**Code:** 8ME1A

Subject Code	COs	Program Specific Outcomes (PSOs)	
		PSO-1	PSO-2
8ME1A	CO-1	3	
	CO-2	3	3
	CO-3	3	

*Table B.3.1.2b*

**3.1.3. Program level Course-PO matrix of all courses INCLUDING first year Courses (10)**

Subject Code	Program Outcomes (POs)											
	PO-1	PO-2	PO-3	PO-4	PO-5	PO-6	PO-7	PO-8	PO-9	PO-10	PO-11	PO-12
8ME1A	3		2	2	3					2	3	
8ME2A		3				2	2	2.33				
8ME3A	3	2	2.25	2	2	2	2	2	2	2	2	2
8ME4.1A	3	2.67	2.33	2								
8ME5A	3	2	2							2		2
8ME6A	3	2	3		3							
8ME7A	3	3	3	2	2	2		2	2.5		2	3
8MEPR	3	3	3		2		3	3	3	3	3	3
8MESM	3	3			3	2	2	2.67	3	2.67		3
7ME1A	2.33	2.67	3	3	3					3		
7ME2A	3	3	3	2.5		2	2.67				3	1.5
7ME3A	3	3	2	1.25	3				3	2	3	2
7ME4A	3	2.5	3	3			2					
7ME5A	2.5	3	3		3	3	2.5	3		2.33	2.33	3
7ME6.1A	2.67	2.33	1.5	2.33	3	2	3	3	1.5		3	2.5
7ME7A	3	3	3	3			3		2			
7ME8A	3	2.5	3	2.5	3							

## [SELF ASSESSMENT REPORT]



7METR	3	2			2.5	3	3	3	2	3		3
7MEPR	3	3	3		2		3	3	3	3	3	3
6ME1A	3	2.33	3	1.5						2.75	2	
6ME2A	3	2	2		2	3	2					2
6ME3A	3	2.25	2.25	1.75	1	1.67	1.75		1.5	1.5	1.75	2
6ME4A	3	2.67	2		1	2	2			2		2
6ME5A	3	2	2				2					1.5
6ME6.3A	3		2.67		2.25	2.5	2		2		3	3
6ME7A	3	2.5	3	2						2.5	2	
6ME8A	3	1			1	0.5						2
6ME9A	2.3	1.7	2.3	2	3	1.5	1.5		1.3	3	2	2
6ME10A	3	2			2	2	1.5		3		1.5	
5ME1A	3	2.5					2.5					2.5
5ME2A	3	3	3									
5ME3A	2.6	2			2.5		2	2	2	2.25		2.4
5ME4A	3	3		3					3		3	
5ME5A	3					2.67	2.33	3	3	2.5	3	3
5ME6.2A	3	2	2		2.33	2.33		2.67		2	2.5	2
5ME7A	3						3		3			3
5ME8A	3	3	3									2.5
5ME9A	3	2	2		3	2			2			2
5ME10A	2					3	3	3	2	3		2
4ME1A	3	3	2.67	3								
4ME2A	3	1.75	1.5			1						
4ME3A	2.25	1	1.5	1	2.25	2				2		1.5
4ME4A	3	2	3		2		2			2.5	2	
4ME5A	3	2.5	3	2	2.5	2.5	3	2.5	2.5	3	3	3
4ME6A	3	2.5	2	2	3	2	2.5			2	2.33	
4ME7A	3	3							3			2

## [SELF ASSESSMENT REPORT]



4ME8A	3	2					2		2.5			
4ME9A	3	3	3						2			2.5
4ME10A	3	2.5			2		2			2.5	2	
4ME11A	3	3	2	2.5		2	3		2		2.5	2
3ME1A	3	1.5										2
3ME2A	3	2.25										3
3ME3A	3	2.33	2	2		2.33	2.5				2	2
3ME3A	3	2.5	2.5	3		3			2			
3ME5A	3	2.25	2	1.67	1.75				1.33	2.25	1.33	1
3ME6A	3	2	1	1	1.25	1	1		1	1		1
3ME7A	3		1.5						3			
3ME8A	3	3							2			
3ME9A	3	3	3		2		3					
3ME10A	3	2	2	2	1.5				1	2.5	1	1
3ME11A	2			3					2.5	3	2.5	3
MA-102	3	3								1		1
HU-103			2			3	2	3	2	1		1
CY-101	2	1	1	1		1	1			1		
CE-103	1.5	1	1			1	1	1	1	1	1	1
CS-103	2.25	1.75	1.5	2.25	2	1.75	2			2		1.75
OE-101	3	2										2
HU-104			1			3	3	3	1	1		1
CY-102	2	2		1					1			
CS-104	2	2	3	1					2	1	2	1
ME-104	3	2	2		2	2	2			2		2
MA-101	3	3								1		1
HU-101		1	2			1			3	3		1
PY-101	2	1	1			1			1	1		1
CS-101	2.5	1.67	1.5			1			2	1.6		1

## [SELF ASSESSMENT REPORT]



CE-101	2	1	1	1		1.75	1.75	1.67	2	1		1.33
HU-102		1				1			3	3		1
PY-102	2	1	1			1			1	1		2
CS-102	2	2	3	1					2	1		1
CE-102	3				2					2		2
ME-101	2.5	2	3	1					2	1.5		1.5

*Table B.3.1.3a*

**Program level Course-PSO matrix of all courses INCLUDING first year courses**

Subject Code	Program Specific Outcomes (PSOs)	
	PSO-1	PSO-2
8ME1A	3	3
8ME2A	0	0
8ME3A	0	0
8ME4.1A	2	0
8ME5A	0	3
8ME6A	3	3
8ME7A	3	0
8MEPR	3	2.67
8MESM	3	3
7ME1A	3	3
7ME2A	0	0
7ME3A	0	0
7ME4A	0	0
7ME5A	0	0
7ME6.1A	0	0
7ME7A	0	0
7ME8A	3	3
7METR	0	0
7MEPR	2	2
6ME1A	2.5	1.5
6ME2A	0	0
6ME3A	2.5	0
6ME4A	2	0
6ME5A	0	0
6ME6.3A	3	0
6ME7A	3	2
6ME8A	3	2

## [SELF ASSESSMENT REPORT]



6ME9A	3	2
6ME10A	0	0
5ME1A	0	0
5ME2A	2.5	0
5ME3A	1.66	2.33
5ME4A	2	2
5ME5A	0	0
5ME6.2A	2.75	0
5ME7A	0	0
5ME8A	2	2
5ME9A	2	0
5ME10A	0	0
4ME1A	2.5	1
4ME2A	0	0
4ME3A	3	2
4ME4A	2.5	2
4ME5A	0	0
4ME6A	3	0
4ME7A	3	0
4ME8A	0	0
4ME9A	3	0
4ME10A	3	2
4ME11A	2	0
3ME1A	1.5	0
3ME2A	1	0
3ME3A	2	0
3ME4A	2.5	0
3ME5A	0	1
3ME6A	0	0
3ME7A	2	0
3ME8A	1	0
3ME9A	2.5	0
3ME10A	0	0
3ME11A	3	3
205	2	0
210	2	2
109	0	0
110	2	0

*Table B.3.1.3b*

**3.2 ATTAINMENT OF COURSE OUT COMES (50)**

**3.2.1 Describe the assessment process use together the data up on which the evaluation of courses outcome based (10)**

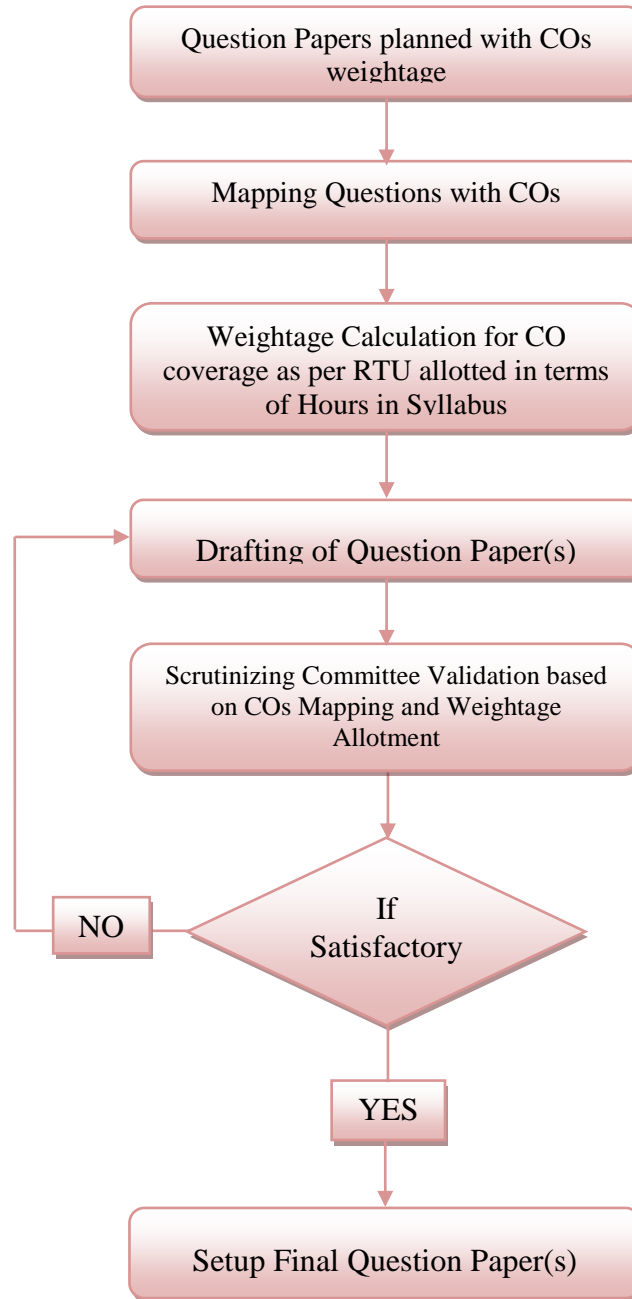

**Figure 3.1 Evaluation process (a)**



# [SELF ASSESSMENT REPORT]

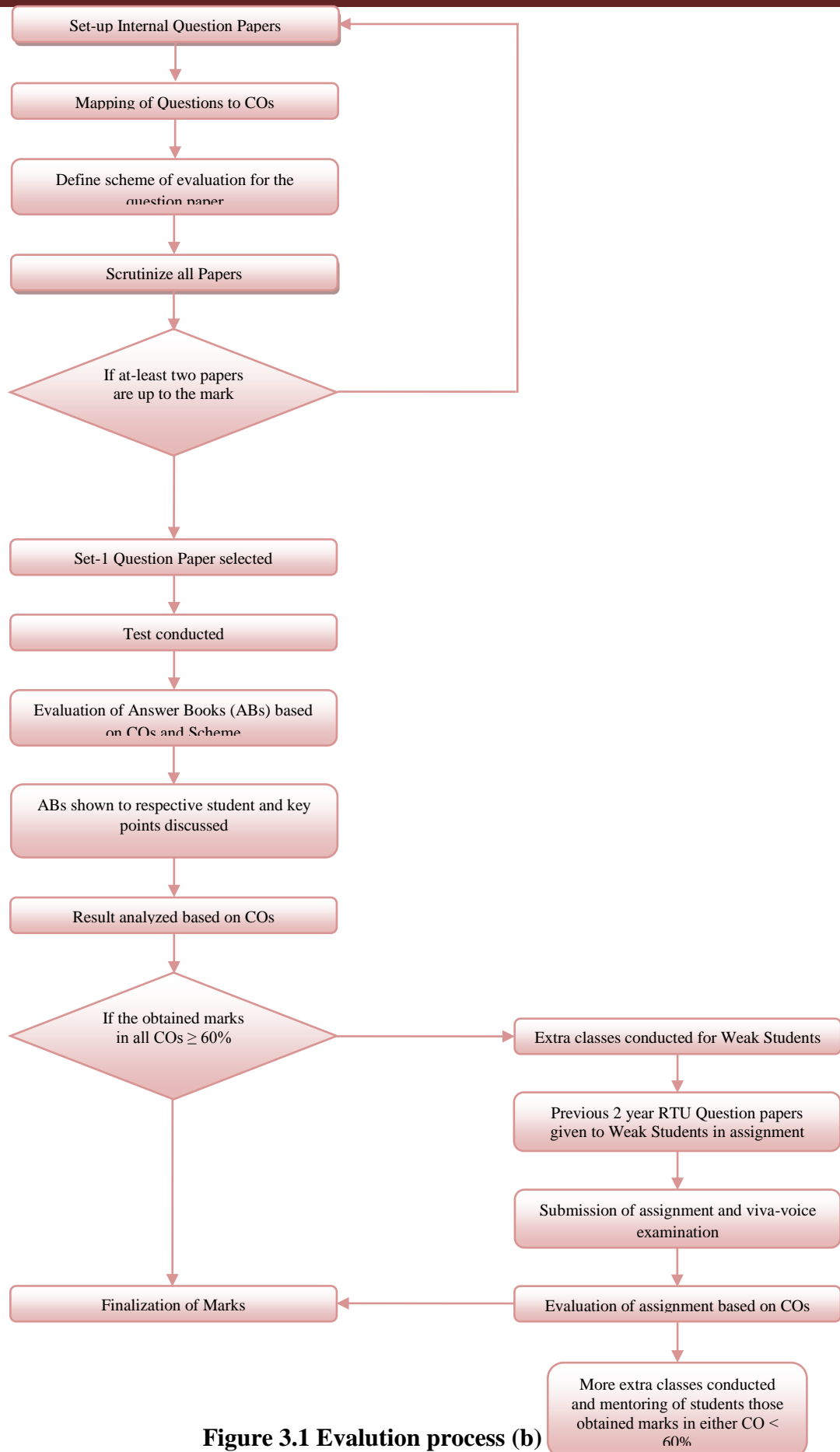

**Figure 3.1 Evaluation process (b)**

## [SELF ASSESSMENT REPORT]



- The assessment process used to evaluate course outcome is mainly assessment with weightage of 80% (direct assessment) and 20% to course exit survey (indirect assessment).
- Assignments are given to improve the internal exam result.
- The IQAC committee have created a Excel spread sheet to assess the course outcomes and Program outcomes
- Internal marks are mapped with COs. More than 60% marks in each CO is targets for assessment of course outcomes. The Excel sheet calculates the attainment for each outcome.

### 3.2.2 Record the attainment course outcomes of all courses with respect to set attainment levels (40)

#### CO ATTAINMENT (2017-18)

SUBJECT	COURSE OUTCOME	CO ATTAINMENT VALUE (%)
8ME1A	CO-1	79.20
	CO-2	65.20
	CO-3	90.40
8ME2A	CO-1	93.00
	CO-2	75.80
	CO-3	82.60
8ME3A	CO-1	79.52
	CO-2	74.40
	CO-3	40.92
	CO-4	36.33
8ME4.1A	CO-1	56.00
	CO-2	51.00
	CO-3	71.40
8ME5A	CO-1	66.00
	CO-2	57.00
8ME6A	CO-1	91.60
	CO-2	91.80
8ME7A	CO-1	93.00
	CO-2	92.00
8MEPR	CO-1	90.80
	CO-2	88.60
	CO-3	93.14
	CO-4	92.34
8MESM	CO-1	94.34
	CO-2	92.34
	CO-3	89.85
7ME1A	CO-1	89.52
	CO-2	81.09

## [SELF ASSESSMENT REPORT]



	CO-3	77.64
7ME2A	CO-1	55.39
	CO-2	53.94
	CO-3	39.18
	CO-4	63.67
7ME3A	CO-1	74.20
	CO-2	48.20
	CO-3	68.84
	CO-4	46.65
7ME4A	CO-1	73.52
	CO-2	63.26
	CO-3	59.80
	CO-4	55.70
7ME5A	CO-1	60.40
	CO-2	39.00
	CO-3	19.83
	CO-4	18.05
7ME6.1A	CO-1	31.94
	CO-2	28.87
	CO-3	35.23
	CO-4	50.98
7ME7A	CO-1	54.36
	CO-2	87.63
7ME8A	CO-1	89.37
	CO-2	93.14
7METR	CO-1	91.26
	CO-2	91.74
	CO-3	86.29
7MEPR	CO-1	84.13
	CO-2	93.14
	CO-3	92.34
	CO-4	94.34
6ME1A	CO-1	93.14
	CO-2	44.64
	CO-3	21.70
	CO-4	55.24
6ME2A	CO-1	27.13
	CO-2	57.99
	CO-3	67.05
	CO-4	62.44
6ME3A	CO-1	59.15
	CO-2	77.31

## [SELF ASSESSMENT REPORT]



	CO-3	45.27
	CO-4	61.70
6ME4A	CO-1	76.46
	CO-2	71.32
	CO-3	64.15
	CO-4	37.44
6ME5A	CO-1	19.56
	CO-2	81.59
	CO-3	43.09
6ME6.3A	CO-1	25.45
	CO-2	90.11
	CO-3	73.46
	CO-4	82.16
6ME7A	CO-1	82.41
	CO-2	77.20
6ME8A	CO-1	79.16
	CO-2	88.40
6ME9A	CO-1	79.16
	CO-2	88.40
	CO-3	82.60
6ME10A	CO-1	82.60
	CO-2	91.60
5ME1A	CO-1	31.07
	CO-2	21.83
	CO-3	52.35
	CO-4	47.74
5ME2A	CO-1	72.60
	CO-2	39.20
	CO-3	64.40
	CO-4	71.00
5ME3A	CO-1	96.99
	CO-2	94.46
	CO-3	73.36
	CO-4	96.97
	CO5	89.11
5ME4A	CO-1	70.80
	CO-2	64.40
	CO-3	55.20
	CO4	84.80
	CO5	69.20
5ME5A	CO-1	93.00
	CO-2	75.80

## [SELF ASSESSMENT REPORT]



	CO-3	82.60
	CO4	79.52
	CO5	74.40
5ME6.2A	CO-1	75.00
	CO-2	92.00
	CO3	66.80
	CO4	75.60
5ME7A	CO-1	84.40
	CO-2	80.20
5ME8A	CO-1	88.00
	CO-2	89.00
5ME9A	CO-1	90.97
	CO-2	88.62
5ME10A	CO-1	90.62
	CO-2	88.63
4ME1A	CO-1	44.20
	CO-2	27.80
	CO-3	38.00
	CO-4	47.60
4ME2A	CO-1	57.30
	CO-2	35.97
	CO-3	68.99
	CO-4	32.30
4ME3A	CO-1	60.00
	CO-2	18.20
	CO-3	37.80
	CO-4	30.40
4ME4A	CO-1	59.77
	CO-2	56.74
	CO-3	54.30
	CO-4	62.40
4ME5A	CO-1	36.54
	CO-2	30.26
	CO-3	29.84
	CO4	22.08
4ME6A	CO-1	81.00
	CO-2	48.00
	CO-3	50.00
	CO-4	50.00
4ME7A	CO-1	80.80
	CO-2	80.20
4ME8A	CO-1	91.14

## [SELF ASSESSMENT REPORT]



	CO-2	92.36
4ME9A	CO-1	89.40
	CO-2	88.20
4ME10A	CO-1	69.60
	CO-2	68.60
4ME11A	CO-1	71.00
	CO-2	77.40
3ME1A	CO-1	52.08
	CO-2	43.89
	CO-3	83.75
3ME2A	CO-1	59.40
	CO-2	15.60
	CO-3	50.60
	CO-4	52.60
	CO-5	21.20
3ME3A	CO-1	61.12
	CO-2	54.88
	CO-3	60.23
	CO-4	65.47
3ME4A	CO-1	56.90
	CO-2	32.00
	CO-3	78.80
	CO-4	76.80
3ME5A	CO-1	52.25
	CO-2	51.85
	CO-3	68.08
	CO-4	48.14
3ME6A	CO-1	79.27
	CO-2	65.40
	CO-3	82.54
	CO-4	78.93
3ME7A	CO-1	77.80
	CO-2	82.60
3ME8A	CO-1	86.20
	CO-2	83.40
3ME9A	CO-1	94.68
	CO-2	90.64
3ME10A	CO-1	89.40
	CO-2	88.20
3ME11A	CO-1	83.80
	CO-2	85.20

# [SELF ASSESSMENT REPORT]



## CO ATTAINMENT (2016-17)

SUBJECT	COURSE OUTCOME	CO ATTAINMENT VALUE (%)
8ME1A	CO-1	53.2
	CO-2	70
	CO-3	38.4
8ME2A	CO-1	76.4
	CO-2	57.4
	CO-3	88.8
	CO-4	91.4
8ME3A	CO-1	56.04
	CO-2	44.8
	CO-3	56.48
	CO-4	49.08
8ME4.1A	CO-1	55.84
	CO-2	34.6
	CO-3	22.4
8ME5A	CO-1	89.8
	CO-2	91
8ME6A	CO-1	93.29
	CO-2	92.49
8ME7A	CO-1	82.2
	CO-2	86
8MEPR	CO-1	92.91
	CO-2	93.71
	CO-3	92.91
	CO-4	94.91
8MESM	CO-1	84.44
	CO-2	84.96
	CO-3	87.4
7ME1A	CO-1	70
	CO-2	68.33
	CO-3	15.96
7ME2A	CO-1	51.85
	CO-2	37.24
	CO-3	50.37
	CO-4	40.48
7ME3A	CO-1	50.8
	CO-2	49.13
	CO-3	45.56
	CO-4	56.92
7ME4A	CO-1	53.2
	CO-2	34.4
	CO-3	29.08
	CO-4	43.8
7ME5A	CO-1	61.2
	CO-2	44.256

## [SELF ASSESSMENT REPORT]



	CO-3	60.09
	CO-4	41.25
7ME6.1A	CO-1	67.94
	CO-2	60.09
	CO-3	41.25
	CO-4	38.72
7ME7A	CO-1	84.44
	CO-2	84.96
7ME8A	CO-1	72
	CO-2	78.6
7METR	CO-1	93.72
	CO-2	91.16
	CO-3	89.96
7MEPR	CO-1	92.92
	CO-2	93.72
	CO-3	91.16
	CO-4	89.96
6ME1A	CO-1	27.2
	CO-2	28.2
	CO-3	28.92
	CO-4	74.8
6ME2A	CO-1	53.10
	CO-2	50.04
	CO-3	62.36
	CO-4	25.035
6ME3A	CO-1	76.4
	CO-2	54.50
	CO-3	67.74
	CO-4	71.31
6ME4A	CO-1	64.95
	CO-2	32.34
	CO-3	39.60
	CO-4	42.94
6ME5A	CO-1	19.81
	CO-2	31.48
	CO-3	37.36
6ME6.3A	CO-1	63.10
	CO-2	57.70
	CO-3	70.04
	CO-4	53.13
6ME7A	CO-1	76.17
	CO-2	79.91
6ME8A	CO-1	87.75
	CO-2	90.19
6ME9A	CO-1	95.90
	CO-2	94.50
6ME10A	CO-1	88
	CO-2	87.4



## [SELF ASSESSMENT REPORT]



5ME1A	CO-1	41.73
	CO-2	27.4
	CO-3	37.66
	CO-4	41.2
5ME2A	CO-1	69.4
	CO-2	64.2
	CO-3	40.4
	CO-4	44.6
5ME3A	CO-1	65.55
	CO-2	24.53
	CO-3	29.72
	CO-4	54.66
	CO5	65.55
5ME4A	CO-1	44
	CO-2	42.4
	CO-3	43.6
	CO4	58.8
	CO5	55.2
5ME5A	CO-1	53.4
	CO-2	72.6
	CO-3	55.12
	CO4	59.6
5ME6.2A	CO-1	60.64
	CO-2	59.6
	CO3	60.64
	CO4	61.12
5ME7A	CO-1	83.72
	CO-2	81
5ME8A	CO-1	84
	CO-2	82.8
5ME9A	CO-1	91.79
	CO-2	90.472
5ME10A	CO-1	81.33
	CO-2	81.99
4ME1A	CO-1	53.2
	CO-2	44
	CO-3	32.6
	CO-4	28
4ME2A	CO-1	71.46
	CO-2	38.44
	CO-3	70.336
	CO-4	41.04
4ME3A	CO-1	88.2
	CO-2	83.8
	CO-3	79.2
	CO-4	28.6
4ME4A	CO-1	63.27
	CO-2	49.77

## [SELF ASSESSMENT REPORT]



	CO-3	49.61
	CO-4	42.98
4ME5A	CO-1	61.37
	CO-2	45.70
	CO-3	73.74
	CO4	63.71
4ME6A	CO-1	73
	CO-2	39.2
	CO-3	64.2
	CO-4	48.4
4ME7A	CO-1	75.8
	CO-2	77.6
4ME8A	CO-1	91.12
	CO-2	89.96
4ME9A	CO-1	88.8
	CO-2	89.2
4ME10A	CO-1	73
	CO-2	71.4
4ME11A	CO-1	77.6
	CO-2	82.6
3ME1A	CO-1	71.08
	CO-2	54.49
	CO-3	20.47
3ME2A	CO-1	39.6
	CO-2	39.4
	CO-3	52
	CO4	35.2
	CO5	28.8
3ME3A	CO-1	54.10
	CO-2	41.67
	CO-3	56.84
	CO-4	63.68
3ME4A	CO-1	26.56
	CO-2	19.64
	CO-3	30.64
	CO-4	39.6
3ME5A	CO-1	54.50
	CO-2	42.07
	CO-3	56.44
	CO-4	62.08
3ME6A	CO-1	31.04
	CO-2	49.59
	CO-3	55.28
3ME7A	CO-1	77.96
	CO-2	76.2
3ME8A	CO-1	82.8
	CO-2	81.24

## [SELF ASSESSMENT REPORT]



3ME9A	CO-1	86.4
	CO-2	90.32
3ME10A	CO-1	87.6
	CO-2	85.2
3ME11A	CO-1	84.6
	CO-2	84.41

### CO ATTAINMENT (2015-16)

SUBJECT	COURSE OUTCOME	CO ATTAINMENT VALUE (%)
8ME1A	CO-1	88.00
	CO-2	84.40
	CO-3	86.80
8ME2A	CO-1	39.00
	CO-2	48.60
	CO-3	32.00
	CO-4	25.48
8ME3A	CO-1	83.00
	CO-2	85.40
	CO-3	87.20
	CO-4	86.60
8ME4.1A	CO-1	72.40
	CO-2	68.60
	CO-3	78.20
8ME5A	CO-1	88.80
	CO-2	86.20
8ME6A	CO-1	96.00
	CO-2	95.47
8ME7A	CO-1	83.80
	CO-2	85.00
8MEPR	CO-1	93.46
	CO-2	95.46
	CO-3	94.26
	CO-4	93.46
8MESM	CO-1	96.00
	CO-2	95.47
	CO-3	88.80
7ME1A	CO-1	35.80
	CO-2	54.33
	CO-3	15.96
7ME2A	CO-1	61.66
	CO-2	40.44
	CO-3	77.75
	CO-4	66.21

## [SELF ASSESSMENT REPORT]



7ME3A	CO-1	44.91
	CO-2	53.53
	CO-3	29.00
	CO-4	52.22
7ME4A	CO-1	51.60
	CO-2	56.40
	CO-3	32.20
	CO-4	50.80
7ME5A	CO-1	58.98
	CO-2	38.40
	CO-3	69.46
	CO-4	48.41
7ME6.1A	CO-1	52.18
	CO-2	52.53
	CO-3	88.01
	CO-4	89.58
7ME7A	CO-1	78.17
	CO-2	82.41
7ME8A	CO-1	90.02
	CO-2	93.46
7METR	CO-1	93.46
	CO-2	91.22
	CO-3	90.02
7MEPR	CO-1	93.46
	CO-2	93.46
	CO-3	58.06
	CO-4	27.96
6ME1A	CO-1	29.00
	CO-2	32.20
	CO-3	55.82
	CO-4	56.26
6ME2A	CO-1	61.10
	CO-2	28.21
	CO-3	69.46
	CO-4	48.41
6ME3A	CO-1	52.18
	CO-2	52.53
	CO-3	59.55
	CO-4	30.86
6ME4A	CO-1	36.50
	CO-2	31.90
	CO-3	35.91
	CO-4	40.90
6ME5A	CO-1	37.54

## [SELF ASSESSMENT REPORT]



	CO-2	77.42
	CO-3	64.90
6ME6.3A	CO-1	77.32
	CO-2	69.34
	CO-3	74.00
	CO-4	77.53
6ME7A	CO-1	80.40
	CO-2	81.95
6ME8A	CO-1	80.74
	CO-2	82.40
6ME9A	CO-1	85.40
	CO-2	86.20
6ME10A	CO-1	24.86
	CO-2	19.26
5ME1A	CO-1	46.06
	CO-2	51.40
	CO-3	46.60
	CO-4	28.40
5ME2A	CO-1	28.40
	CO-2	31.20
	CO-3	61.00
	CO-4	82.54
5ME3A	CO-1	73.27
	CO-2	75.18
	CO-3	70.00
	CO-4	72.00
	CO5	70.00
5ME4A	CO-1	62.80
	CO-2	59.60
	CO-3	21.60
	CO4	29.88
	CO5	16.96
5ME5A	CO-1	11.14
	CO-2	41.20
	CO-3	49.32
	CO4	74.00
5ME6.2A	CO-1	77.53
	CO-2	81.00
	CO3	82.20
	CO4	94.36
5ME7A	CO-1	92.53
	CO-2	87.68
5ME8A	CO-1	88.49
	CO-2	50.40

## [SELF ASSESSMENT REPORT]



5ME9A	CO-1	30.80
	CO-2	31.80
5ME10A	CO-1	31.60
	CO-2	62.16
4ME1A	CO-1	38.24
	CO-2	76.75
	CO-3	51.38
	CO-4	37.20
4ME2A	CO-1	23.40
	CO-2	28.80
	CO-3	8.95
	CO-4	46.19
4ME3A	CO-1	29.36
	CO-2	29.89
	CO-3	40.42
	CO-4	65.98
4ME4A	CO-1	45.53
	CO-2	29.82
	CO-3	30.70
	CO-4	28.16
4ME5A	CO-1	31.24
	CO-2	31.20
	CO-3	74.80
	CO-4	73.40
4ME6A	CO-1	92.71
	CO-2	93.33
	CO-3	0.90
	CO-4	0.86
4ME7A	CO-1	69.60
	CO-2	73.20
4ME8A	CO-1	83.20
	CO-2	80.40
4ME9A	CO-1	49.58
	CO-2	66.77
4ME10A	CO-1	71.54
	CO-2	44.40
4ME11A	CO-1	27.80
	CO-2	73.00
3ME1A	CO-1	55.00
	CO-2	61.60
	CO-3	42.88
3ME2A	CO-1	52.76
	CO-2	48.74
	CO-3	58.02

## [SELF ASSESSMENT REPORT]



	CO4	41.68
	CO5	24.20
3ME3A	CO-1	72.56
	CO-2	56.68
	CO-3	62.87
	CO-4	43.62
3ME4A	CO-1	53.43
	CO-2	79.67
	CO-3	59.90
	CO-4	40.90
3ME5A	CO-1	83.96
	CO-2	0.00
	CO-3	74.20
	CO-4	78.53
3ME6A	CO-1	79.61
	CO-2	82.60
	CO-3	90.64
	CO-4	88.52
3ME7A	CO-1	78.33
	CO-2	81.01
3ME8A	CO-1	82.40
	CO-2	81.40
3ME9A	CO-1	75.42
	CO-2	75.00
3ME10A	CO-1	68.63
	CO-2	69.17
3ME11A	CO-1	60.25
	CO-2	60.05

### 3.3 Attainment of Program Outcomes and Program Specific Outcomes (50)

#### 3.3.1. Describe Assessment tools and Process used for measuring the attainment of each of the program outcomes and program specific outcomes (10)

In Outcome based Education, assessment done through one or more than one processes, carried out by the institution, that identify, collect, and prepare data to evaluate the achievement of programme educational objectives, program outcomes and course objectives and outcomes.

#### PO Assessment Tools

Assessment tools are categorized into academic, placement, beyond curriculum and feedback methods to assess the program outcomes.

- **Academic Assessment** display the student's knowledge and skills from their performance in the MTT, end-semester examinations (RTU exam), project, industrial training and performance in lab. etc.



- **Placement assessment** includes the number of students placed, gone through mentoring, soft skill classes. it also includes the number of student gone for higher studies and placed in PSU and qualified for GATE.
- **Beyond Curriculum assessment** includes the participation of student in various technical, social activities along with participation in conferences and workshops.
- **Feedback assessment** includes the values provide by alumni, the student outgoing of program at the end of final semester and in each semester at the time of course exit.
- Finally IQAC decides the weightage of each tool with regards to each PO. After this an excel sheet is made for calculation the attainment of PO's.
- There is no. of attainment level for each tool in the form of Rubric (attached below) the attained value is filled in sheet according to their respective rubrics.
- The calculations are as below

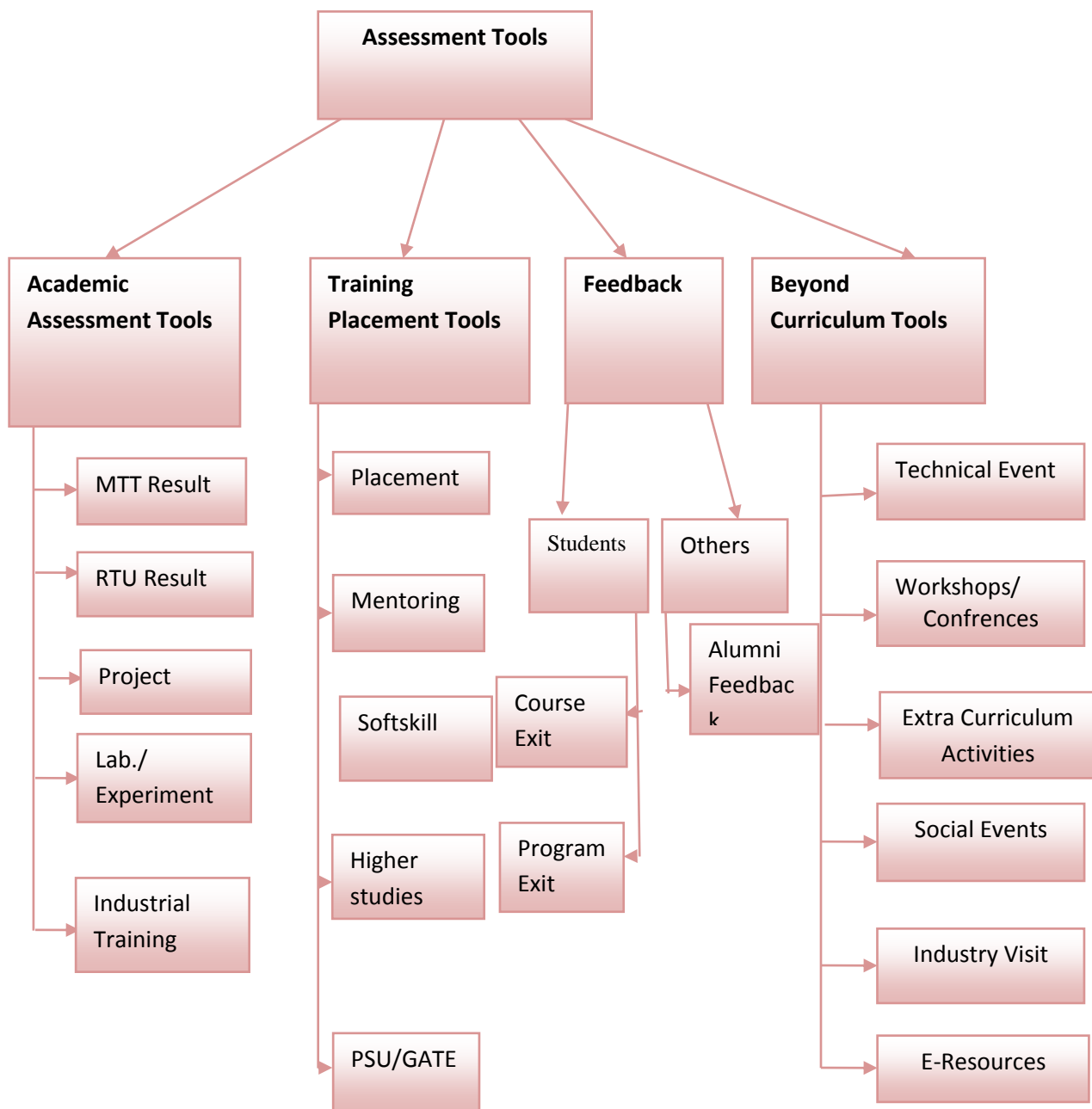

Fig.3.2 PO-assessment tool chart



# [SELF ASSESSMENT REPORT]



The calculations are as below

**Session: 2017-18**

## PO1

Tool	Tools	Weight age (%)	Mapping	Score	marks	Rubric
Academic Assessment 50%	MTT Result	15%	H	3	1.5	70% students >65%=>100% marks 70% students >60%=>80% 60% students >65%=>60% 60% students >60%=>50% Else =>20% marks
	Final RTU Result	5%	L	1	0.2	70% students >65%=>100% marks 70% students >60%=>80% 60% students >65%=>60% 60% students >60%=>50% Else=> 20% marks
	Project	15%	H	3	3	70% students >65%=>100% marks 70% students >60%=>80% 60% students >65%=>60% 60% students >60%=>50% Else=> 0 marks
	Lab/Experiments	10%	M	2	2	80% students >65%=>100% marks 80% students >60%=>80% 70% students >65%=>60% 70% students >60%=>50% Else=> 0 marks
	I Industrial training	5%	L	1	1	>=90% students visited =>100% marks >=80% students visited=>80% >=60% students visited =>60% >=50% students visited =>50% Else=> 0 marks
Placement 20%	Core	4%	M	2	1	>=70% students placed =>100% marks 60-69% students placed =>80% 50-59% students placed =>60% 40-49% students placed =>50% Else=> 0 marks
	Mentoring	4%	M	2	2	>=80% students attended =>100% marks 70-79% students attended =>80% 60-69% students attended =>60%

## [SELF ASSESSMENT REPORT]



						50-59% students attended =>50% Else=> 0 marks
	Softskill	3%	L	1	1	>=80% students attended =>100% marks 70-79% students attended =>80% 60-69% students attended =>60% 50-59% students attended =>50% Else=> 0 marks
	Higher Studies	4%	M	2	1.2	>=20% students =>100% marks 15-19% students =>80% 10-14% students =>60% 5-9% students =>50% Else=> 0 marks
	PSU/GATE	5%	H	3	1.8	>=20% students cleared =>100% marks 15-19% students cleared =>80% 10-14% students cleared =>60% 5-9% students cleared =>50% Else=> 0 marks
Beyond Curriculum 20%	Technical Events	5%	H	3	3	>=80% students participated =>100% marks 70-79% students participated =>80% 60-69% students participated =>60% 50-59% students participated =>50% Else=> 0 marks
	Conference/Workshops	4%	M	2	2	>=10% students participated =>100% marks 8-9 % students participated =>80% 6-7 % students participated =>60% 4-5 % students participated =>50% Else=> 0 marks
	Social Events	3%	L	1	1	>=25% students participated =>100% marks 20-24 % students participated =>80% 15-19 % students participated =>60% 10-14 % students participated =>50% Else=> 0 marks
	E-Resources	3%	M			>=50% students =>100% marks

## [SELF ASSESSMENT REPORT]



				2	2	40-49 % students =>80% 30-39 % students =>60% 20-29 % students =>50% Else=> 0 marks
	Industrial visit	5%	H	3	3	>=50% students =>100% marks 40-49 % students =>80% 30-39 % students =>60% 20-29 % students =>50% Else=> 0 marks
	Extra Curricular Activity	NA	NA			>=25% students participated =>100% marks 20-24 % students participated =>80% 15-19 % students participated =>60% 10-14 % students participated =>50% Else=> 0 marks
Feedback 10%	Course Exit	4%	H	3	2.4	AVG. Marks given by respondent
	Student Exit	4%	L	1	0.71	AVG. Marks given by respondent
	Alumni	2%	M	2	1.6	AVG. Marks given by respondent

**Note: All other POs calculation is same with different weightages.**

### 3.3.2. Provide the results of evaluation of each PO and PSOs (40)

#### ATTAINMENT OF PO's 2017-18

POs	TARGET	ACHIEVED
PO1	0.746667	0.583133
PO2	0.813333	0.65192
PO3	0.756667	0.662613
PO4	0.95	0.895
PO5	0.83333	0.8117
PO6	0.73333	0.713
PO7	0.73333	0.6803
PO8	0.666	0.615
PO9	0.7666	0.669
PO10	0.5333	0.508
PO11	0.41	0.3689
PO12	0.5	0.43812

# [SELF ASSESSMENT REPORT]

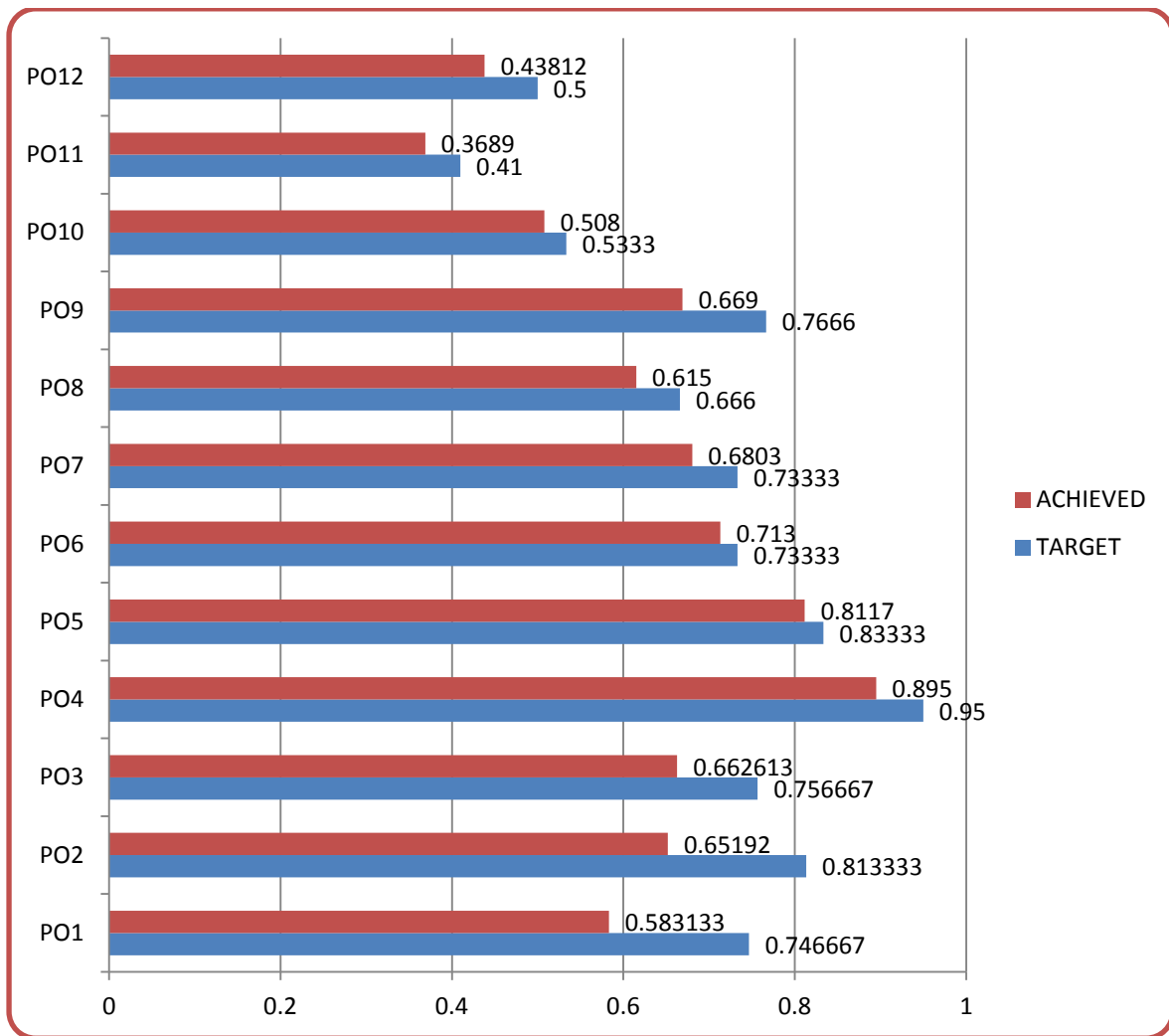

## ATTAINMENT OF PO's 2016-17

POs	TARGET	ACHIEVED
PO1	0.747	0.581
PO2	0.813	0.649
PO3	0.757	0.661
PO4	0.950	0.895
PO5	0.833	0.811
PO6	0.733	0.714
PO7	0.733	0.678
PO8	0.667	0.618
PO9	0.767	0.687
PO10	0.533	0.517
PO11	0.410	0.372
PO12	0.500	0.434

# [SELF ASSESSMENT REPORT]

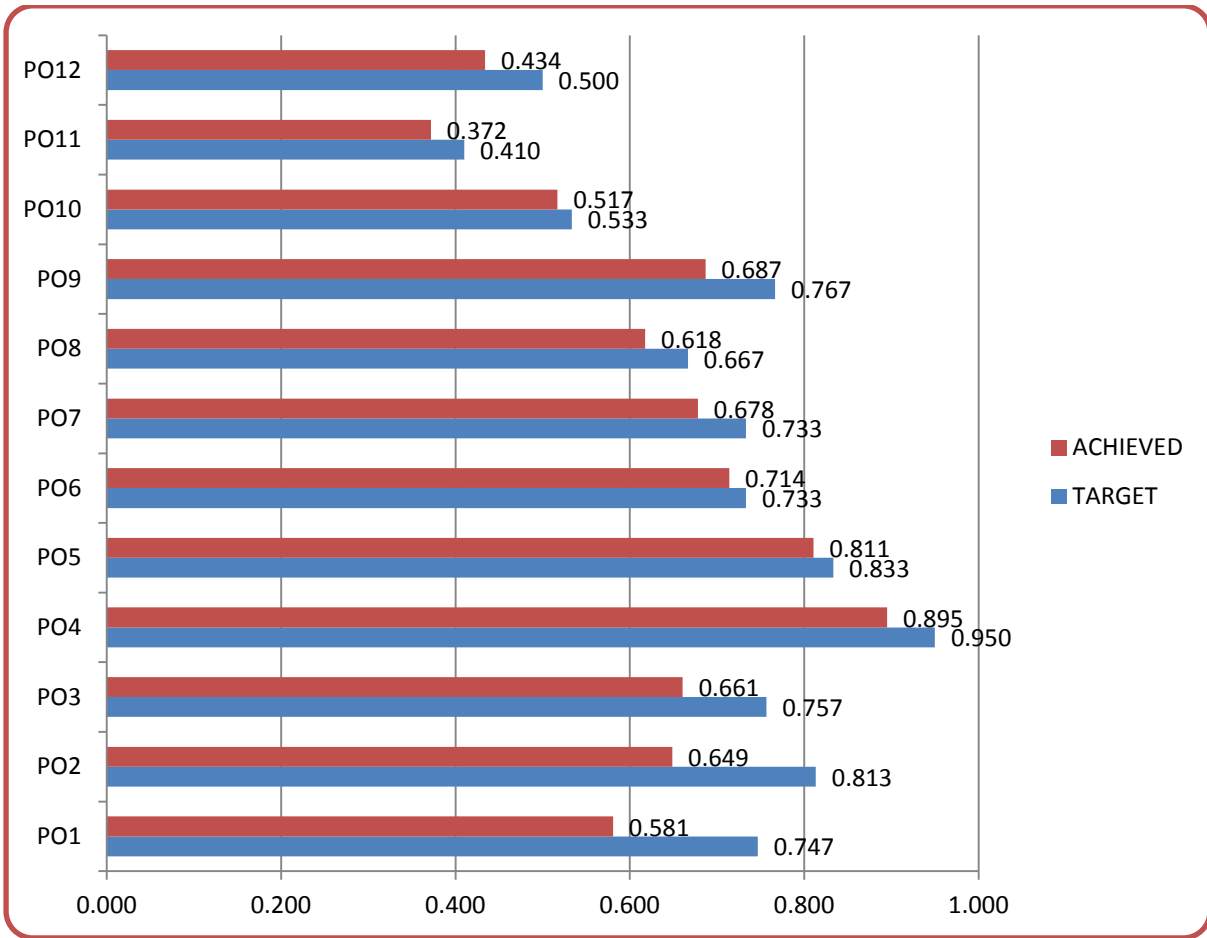

## ATTAINMENT OF PO's 2015-16

POs	TARGET	ACHIEVED
PO1	0.747	0.561
PO2	0.813	0.629
PO3	0.757	0.650
PO4	0.950	0.815
PO5	0.833	0.751
PO6	0.733	0.687
PO7	0.733	0.678
PO8	0.667	0.591
PO9	0.767	0.627
PO10	0.533	0.490
PO11	0.410	0.356
PO12	0.500	0.425

# [SELF ASSESSMENT REPORT]

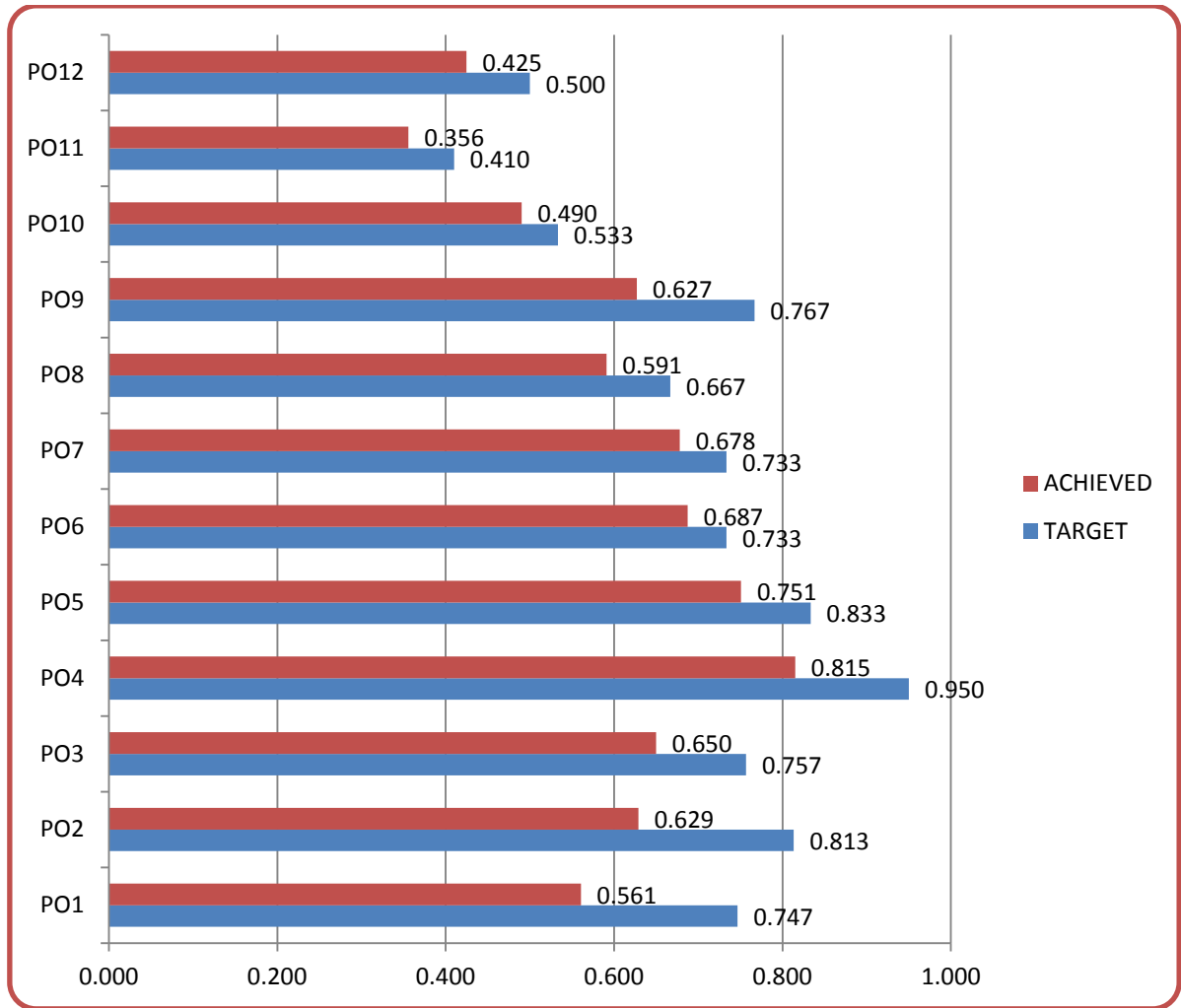

**PO attainment (year wise)**

POs	2017-18	2016-17	2015-16
PO1	0.58313	0.581	0.561
PO2	0.65192	0.649	0.629
PO3	0.66261	0.661	0.65
PO4	0.895	0.895	0.815
PO5	0.8117	0.811	0.751
PO6	0.713	0.714	0.687
PO7	0.6803	0.678	0.678
PO8	0.615	0.618	0.591
PO9	0.669	0.687	0.627
PO10	0.508	0.517	0.49
PO11	0.3689	0.372	0.356
PO12	0.43812	0.434	0.425

# [SELF ASSESSMENT REPORT]

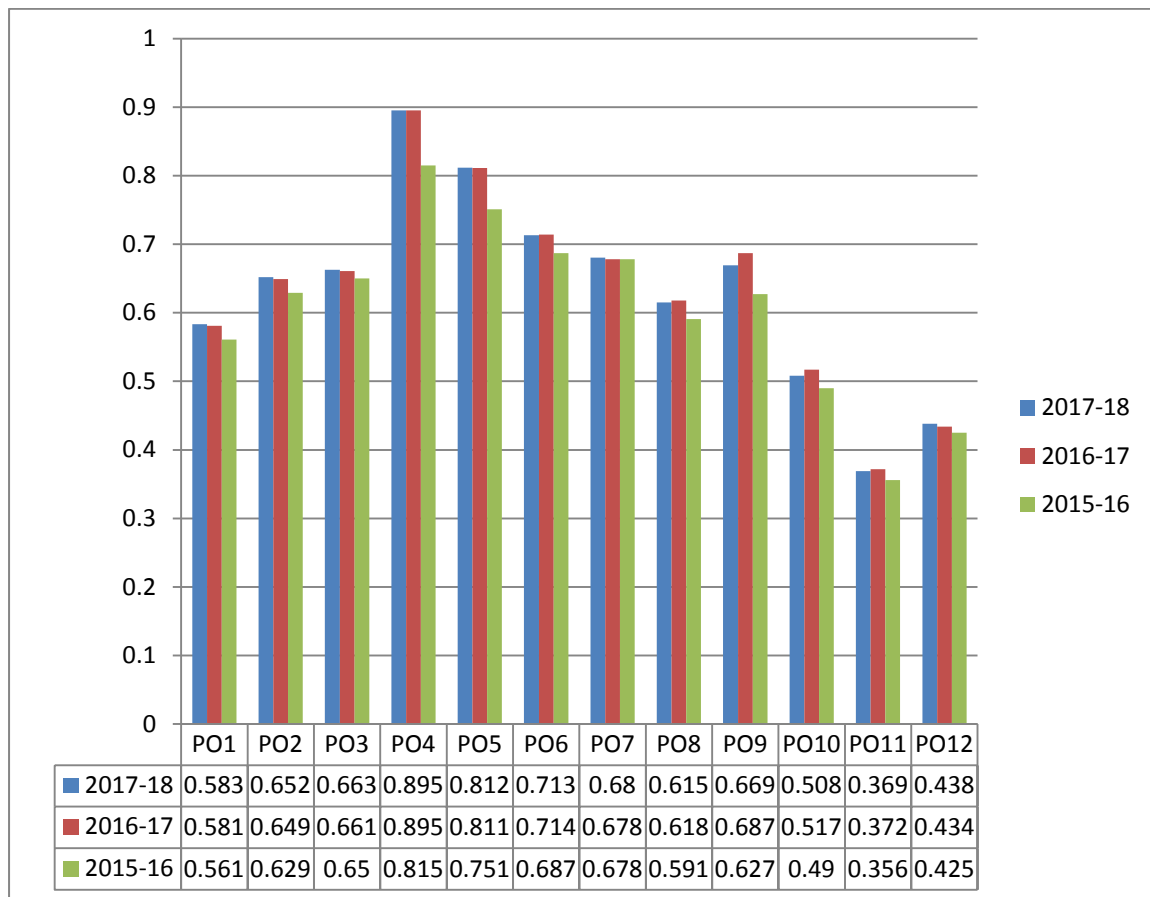

## PSO ATTAINMENT (2017-18)

PSO1. Apply the knowledge of material science, manufacturing and design to implement the various concepts vehicle mechanics.					
Tools	Weightage	Mapping	Marks	Rubric	Marks Obtained
In House Training	15%	H	3	>=50% students Participated=>100% marks	1.80
				>=40% students Participated=>80%	
				>=30% students Participated=>60%	
				Else=>20%	
Project	15%	H	2	70% students >65%=>100% marks	2
				70% students >60%=>80%	
				60% students >65%=>60%	
				60% students >60%=>50%	
				Else=> 0 marks	
Hand on Practice	5%	L	1	>=50% students Participated=>100% marks	0.60
				>=40% students Participated=>80%	

# [SELF ASSESSMENT REPORT]



				>=30% students Participated=>60%	
				Else=>20%	
Industrial training	15%	H	3	>=90% students visited =>100% marks	3
				>=80% students visited=>80%	
				>=60% students visited =>60%	
				>=50% students visited =>50%	
				Else=> 0 marks	
Final Placed Strength	10%	M	2	>=70% students placed => 100% marks	1.2
				60-69% students placed =>80%	
				50-59% students placed =>60%	
				40-49% students placed =>50%	
				Else=> 0 marks	
Mentoring	5%	L	1	>=80% students attended => 100% marks	1
				70-79% students attended =>80%	
				60-69% students attended =>60%	
				50-59% students attended =>50%	
				Else=> 0 marks	
Technical Events	15%	H	3	>=80% students participated => 100% marks	3
				70-79% students participated =>80%	
				60-69% students participated =>60%	
				50-59% students participated =>50%	
				Else=> 0 marks	
Conference/Workshops	5%	L	1	>=10% students participated => 100% marks	1
				8-9 % students participated =>80%	
				6-7 % students participated =>60%	
				4-5 % students participated =>50%	
				Else=> 0 marks	
E-Resources	5%	L	1	>=50% students => 100% marks	1
				40-49 % students =>80%	
				30-39 % students =>60%	
				20-29 % students =>50%	
				Else=> 0 marks	
Industrial visit	10%	M	2	>=50% students => 100% marks	2
				40-49 % students =>80%	
				30-39 % students =>60%	
				20-29 % students =>50%	



# [SELF ASSESSMENT REPORT]



					Else=> 0 marks	
PSO2. Apply the knowledge of 3D printing technology in design and development of prototypes.						
Tools	Weightage	Mapping	Marks	Rubric	Marks Obtained	
In House Training	15%	H	3	>=50% students Participated=>100% marks	1.80	
				>=40% students Participated=>80%		
				>=30% students Participated=>60%		
				Else=>20%		
Project	15%	H	2	70% students >65%=>100% marks	2	
				70% students >60%=>80%		
				60% students >65%=>60%		
				60% students >60%=>50%		
				Else=> 0 marks		
Hand on Practice	5%	L	1	>=50% students Participated=>100% marks	0.60	
				>=40% students Participated=>80%		
				>=30% students Participated=>60%		
				Else=>20%		
Industrial training	15%	H	3	>=90% students visited =>100% marks	3	
				>=80% students visited=>80%		
				>=60% students visited =>60%		
				>=50% students visited =>50%		
				Else=> 0 marks		
Final Placed Strength	10%	M	2	>=70% students placed => 100% marks	1.2	
				60-69% students placed =>80%		
				50-59% students placed =>60%		
				40-49% students placed =>50%		
				Else=> 0 marks		
Mentoring	5%	L	1	>=80% students attended => 100% marks	1	
				70-79% students attended =>80%		
				60-69% students attended =>60%		
				50-59% students attended =>50%		
				Else=> 0 marks		
Technical Events	15%	H	3	>=80% students participated => 100% marks	3	
				70-79% students participated =>80%		
				60-69% students participated =>60%		
				50-59% students participated =>50%		

## [SELF ASSESSMENT REPORT]



				Else=> 0 marks	
Conference/Workshops	5%	L	1	>=10% students participated => 100% marks	1
				8-9 % students participated =>80%	
				6-7 % students participated =>60%	
				4-5 % students participated =>50%	
				Else=> 0 marks	
E-Resources	5%	L	1	>=50% students => 100% marks	1
				40-49 % students =>80%	
				30-39 % students =>60%	
				20-29 % students =>50%	
				Else=> 0 marks	
Industrial visit	10%	M	2	>=50% students => 100% marks	2
				40-49 % students =>80%	
				30-39 % students =>60%	
				20-29 % students =>50%	
				Else=> 0 marks	

### PSO Attainment (Year Wise)

YEAR	PSO1		PSO2	
	TARGET	ACHIVED	TARGET	ACHIVED
2015-16	0.75	0.536	0.75	0.536
2016-17	0.75	0.5966	0.75	0.596
2017-18	0.75	0.6566	0.75	0.656

# [SELF ASSESSMENT REPORT]

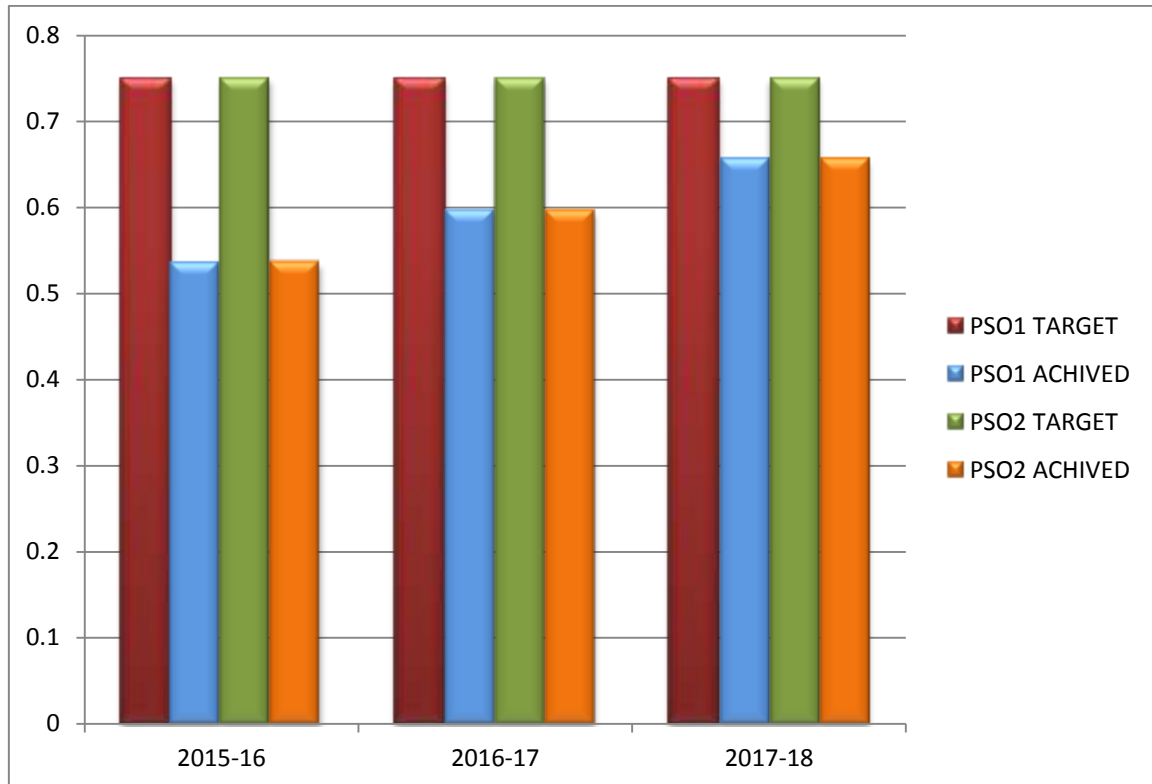



3.3.2. Provide the results of evaluation of each PO and PSOs through course outcome (40)

ATTAINMENT OF POs, PSOs THOURGH COURSE OUTCOME (SAMPLE)

SUBJECT	COURSE OUTCOME	VALUE	Engineering Knowledge	Problem analysis	Design/Development of Solution	Conduct Investigation of complex Problems	Modern Tool Usage	The engineer and society	Environment and Sustainability	Ethics	Individual and Team Work	Communication	Project Management and Finance	Life-long Learning	PSO		
			PO1	PO2	PO3	PO4	PO5	PO6	PO7	PO8	PO9	PO10	PO11	PO12	PSO1	PSO2	
7ME1A: FEM	CO1:	Target Value	2	2		3	3								3	3	
		Attained Value	1.79	1.79	0	2.68	2.68	0	0	0	0	0	0	0	2.68	2.68	
	CO2:	Target Value	2	3	3	3	3					3			3	3	
		Attained Value	1.62	2.43	2.43	2.43	2.43	0	0	0	0	2.43	0	0	2.4328	2.43	
	CO3:	Target Value	3	3	3	3	3						3			3	3
		Attained Value	2.32	2.32	2.32	2.32	2.32	0	0	0	0	2.32	0	0	2.32	2.32	

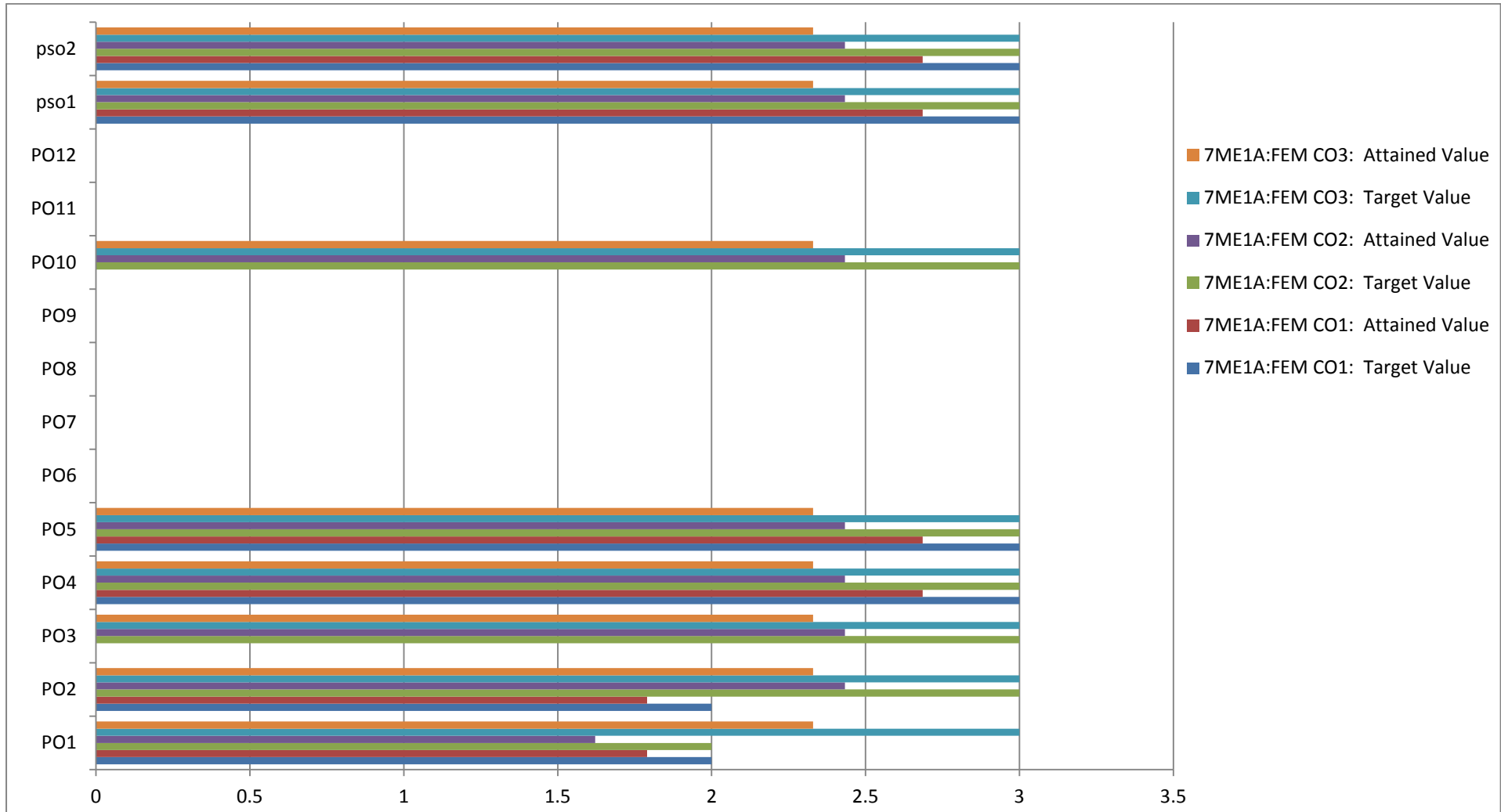

FIG. Attainment of PO's through course outcome (sample)

# [SELF ASSESSMENT REPORT]



## PO'S, PSO'S attainment through CO's (2017-18)

SUBJECT	COURSE OUTCOME	Engineering Knowledge	Problem analysis	Design/Development of Solution	Conduct Investigation of complex Problems	Modern Tool Usage	The engineer and society	Environment and Sustainability	Ethics	Individual and Team Work	Communication	Project Management and Finance	Life-long Learning	PSO	
		PO1	PO2	PO3	PO4	PO5	PO6	PO7	PO8	PO9	PO10	PO11	PO12	PSO1	PSO2
8ME1A	CO-1	2.376	0	1.584	0	2.376	0	0	0	0	1.584	2.376	0	2.376	0
	CO-2	1.956	0	1.304	0	1.956	0	0	0	0	1.304	1.956	0	1.956	1.956
	CO-3	2.712	0	1.808	1.808	2.712	0	0	0	0	1.808	2.712	0	2.712	0
8ME2A	CO-1	0	0	0	0	0	1.86	1.86	2.79	0	0	0	0	0	0
	CO-2	0	2.274	0	0	0	0	1.516	1.516	0	0	0	0	0	0
	CO-3	0	0	0	0	0	0	0	1.652	0	0	0	0	0	0
	-	-	-	-	-	-	-	-	-	-	-	-	-	-	-
	-	-	-	-	-	-	-	-	-	-	-	-	-	-	-
	-	-	-	-	-	-	-	-	-	-	-	-	-	-	-
	-	-	-	-	-	-	-	-	-	-	-	-	-	-	-
	-	-	-	-	-	-	-	-	-	-	-	-	-	-	-
	-	-	-	-	-	-	-	-	-	-	-	-	-	-	-
3ME7A	CO-1	2.47608	0	0.82536	0	0	0	0	0	2.47608	0	0	0	1.65072	0
	CO-2	2.36784	0	1.57856	0	0	0	0	0	2.36784	0	0	0	0	0
3ME8A	CO-1	2.334	2.334	0	0	0	0	0	0	1.556	0	0	0	0.778	0
	CO-2	2.478	2.478	0	0	0	0	0	0	1.652	0	0	0	0.826	0
3ME9A	CO-1	2.586	0	2.586	0	0	0	2.586	0	0	0	0	0	1.724	0
	CO-2	2.502	2.502	2.502	0	1.668	0	0	0	0	0	0	0	2.502	0
3ME10A	CO-1	2.8404	0.9468	1.8936	0	0.9468	0	0	0	0	1.8936	0	0	0	0
	CO-2	2.7192	2.7192	1.8128	1.8128	1.8128	0	0	0	0.9064	2.7192	0.9064	0.9064	0	0
3ME11A	CO-1	1.788	0	0	0	0	0	0	0	2.682	2.682	1.788	2.682	2.682	2.682
	CO-2	0	0	0	2.646	0	0	0	0	1.764	2.646	2.646	0	2.646	2.646

*Table B.3.3.2a*

# [SELF ASSESSMENT REPORT]



## PO'S, PSO'S attainment through CO's (2016-17)

SUBJECT	COURSE OUTCOME	Engineering Knowledge	Problem analysis	Design/Development of Solution	Conduct Investigation of complex Problems	Modern Tool Usage	The engineer and society	Environment and Sustainability	Ethics	Individual and Team Work	Communication	Project Management and Finance	Life-long Learning	PSO	
		PO1	PO2	PO3	PO4	PO5	PO6	PO7	PO8	PO9	PO10	PO11	PO12	PSO1	PSO2
8ME1A	CO-1	1.596	0	1.064	0	1.596	0	0	0	0	1.064	1.596	0	1.596	0
	CO-2	2.1	0	1.4	0	2.1	0	0	0	0	1.4	2.1	0	2.1	2.1
	CO-3	1.152	0	0.768	0.768	1.152	0	0	0	0	0.768	1.152	0	1.152	0
8ME2A	CO-1	0	0	0	0	0	1.528	1.528	2.292	0	0	0	0	0	0
	CO-2	0	1.722	0	0	0	0	1.148	1.148	0	0	0	0	0	0
	CO-3	0	0	0	0	0	0	0	1.776	0	0	0	0	0	0
	-	-	-	-	-	-	-	-	-	-	-	-	-	-	-
	-	-	-	-	-	-	-	-	-	-	-	-	-	-	-
	-	-	-	-	-	-	-	-	-	-	-	-	-	-	-
	-	-	-	-	-	-	-	-	-	-	-	-	-	-	-
3ME7A	CO-1	2.338	0	0.78	0	0	0	0	0	2.34	0	0	0	1.5592	0
	CO-2	2.286	0	1.524	0	0	0	0	0	2.286	0	0	0	0	0
3ME8A	CO-1	2.484	2.484	0	0	0	0	0	0	1.656	0	0	0	0.828	0
	CO-2	2.4374	2.437	0	0	0	0	0	0	1.625	0	0	0	0.8124	0
3ME9A	CO-1	2.592	0	2.592	0	0	0	2.592	0	0	0	0	0	1.728	0
	CO-2	2.7096	2.71	2.71	0	1.8064	0	0	0	0	0	0	0	2.7096	0
3ME10A	CO-1	2.628	0.876	1.752	0	0.876	0	0	0	0	1.752	0	0	0	0
	CO-2	2.556	2.556	1.704	1.704	1.704	0	0	0	0.852	2.556	0.852	0.852	0	0
3ME11A	CO-1	1.692	0	0	0	0	0	0	0	2.538	2.538	1.692	2.538	2.538	2.538
	CO-2	0	0	0	2.5325	0	0	0	0	1.688	2.5325	2.5325	0	2.5325	2.53248

*Table B.3.3.2b*

# [SELF ASSESSMENT REPORT]



## ATTAINMENT OF PO's AND PSO's THROUGH CO's (2015-16)

SUBJECT	COURSE OUTCOME	Engineering Knowledge	Problem analysis	Design/Development of Solution	Conduct Investigation of complex Problems	Modern Tool Usage	The engineer and society	Environment and Sustainability	Ethics	Individual and Team Work	Communication	Project Management and Finance	Life-long Learning	PSO	
		PO1	PO2	PO3	PO4	PO5	PO6	PO7	PO8	PO9	PO10	PO11	PO12	PSO1	PSO2
8ME1A	CO-1	2.64	0	1.76	0	2.64	0	0	0	0	1.76	2.64	0	2.64	0
	CO-2	2.532	0	1.688	0	2.532	0	0	0	0	1.688	2.532	0	2.532	2.532
	CO-3	2.604	0	1.736	1.736	2.604	0	0	0	0	1.736	2.604	0	2.604	0
8ME2A	CO-1	0	0	0	0	0	0.78	0.78	1.17	0	0	0	0	0	0
	CO-2	0	1.458	0	0	0	0	0.97	0.97	0	0	0	0	0	0
	CO-3	0	0	0	0	0	0	0	0.64	0	0	0	0	0	0
-	-	-	-	-	-	-	-	-	-	-	-	-	-	-	-
-	-	-	-	-	-	-	-	-	-	-	-	-	-	-	-
-	-	-	-	-	-	-	-	-	-	-	-	-	-	-	-
3ME7A	CO-1	2.35	0	0.78328	0	0	0	0	0	2.34984	0	0	0	1.5666	0
	CO-2	2.43	0	1.62016	0	0	0	0	0	2.43024	0	0	0	0	0
3ME8A	CO-1	2.472	2.472	0	0	0	0	0	0	1.648	0	0	0	0.824	0
	CO-2	2.442	2.442	0	0	0	0	0	0	1.628	0	0	0	0.814	0
3ME9A	CO-1	2.263	0	2.26248	0	0	0	2.26	0	0	0	0	0	1.5083	0
	CO-2	2.25	2.24988	2.24988	0	1.5	0	0	0	0	0	0	0	2.2498	0
3ME10A	CO-1	2.059	0.68634	1.37267	0	0.69	0	0	0	0	1.37267	0	0	0	0
	CO-2	2.075	2.07508	1.38339	1.38339	1.384	0	0	0	0.6917	2.0751	0.6917	0.6917	0	0
3ME11A	CO-1	1.205	0	0	0	0	0	0	0	1.80744	1.80744	1.20496	1.80744	1.8075	1.8075
	CO-2	0	0	0	1.80	0	0	0	0	1.20096	1.80144	1.80144	0	1.8014	1.8014

*Table B.3.3.2c*



## [SELF ASSESSMENT REPORT]



<b>CRITERION 4</b>	<b>STUDENT PERFORMANCE</b>	<b>(150)</b>
--------------------	----------------------------	--------------

### 4. STUDENTS' PERFORMANCE (150)

#### Admission details for past three years

Item (Information to be provided cumulatively for all the shifts with explicit headings, wherever applicable)	CAYp1 (2018-19)	CAY (2017-18)	CAYm1 (2016-17)
Sanctioned intake of the program (N)	120	120	120
Total number of students admitted in first year minus number of students migrated to other programs/institutions plus no. of students migrated to this program (N1)	123	123	122
Number of students admitted in 2nd year in the same batch via lateral entry (N2)	NIL	14	09
Separate division students, if applicable (N3)	NIL	NIL	NIL
Total number of students admitted in the Program (N1 + N2 + N3)	123	137	131

*Table B.4a*

#### Number of students successfully graduated without backlog

Year of entry	N1 + N2 + N3 (As defined above)	Number of students who have successfully graduated without backlogs in any semester/year of study (Without Backlog means no compartment or failures in any semester/year of study)			
		1Year	2Year	3Year	4Year
CAYp1 (2018-2019)	123	-	-	-	-
CAY (2017-2018)	137	103	-	-	-
CAYm1 (2016-2017)	131	72	66	-	-
CAYm2 (2015-2016)	138	78	58	56	-
CAYm3 (LYG) (2014-2015)	150	80	74	68	62
CAYm4 (LYGm1)(2013-2014)	150	71	58	52	50
CAYm5 (LYGm2)(2012-2013)	157	91	74	69	58

*Table B.4b*



**Number of students graduated successfully**

Year of entry	N1 + N2 + N3 (As defined above)	Number of students who have successfully graduated (Students with backlog in stipulated period of study)			
		1Year	2Year	3Year	4Year
CAYp1 (2018-2019)	123	-	-	-	-
CAY (2017-2018)	137	23	-	-	-
CAYm1 (2016-2017)	131	52	41	-	-
CAYm2 (2015-2016)	138	48	69	24	-
CAYm3 (LYG) (2014-2015)	150	43	82	65	40
CAYm4 (LYGm1)(2013-2014)	150	44	70	59	56
CAYm5 (LYGm2)(2012-2013)	157	42	80	54	65

*Table B.4c*

**4.1. Enrolment Ratio (20)**

**Enrolment Ratio=  $N1/N = 20$**

**Enrolment ratio**

Item	CAYp1 (2018-19)	CAY (2017-18)	CAYm1 (2016-2017)
Sanctioned intake of the program (N)	120	120	120
Total number of students admitted in first year minus number of students migrated to other programs/institutions plus no. of students migrated to this program (N1)	123	123	122
Enrolment Ratio	1.02	1.02	1.01
Enrolment Percentage	100+	100+	100+

*Table B.4.1*

**4.2. Success Rate in the Stipulated Period of the Program (40)**

**4.2.1. Success Rate without Backlogs in any Semester/Year of Study (25)**

SI= (Number of students who have graduated from the program without backlog)/ (Number of students admitted in the first year of that batch and admitted in 2nd year via lateral entry and separate division, if applicable).

Average SI = Mean of Success Index (SI) for past three batches.

Success rate without backlogs in any year of study =  $25 \times \text{Average SI}$



**Success rate without backlogs**

Item	LYG (CAYm3) (2014-15)	LYGm1(CAYm4) (2013-14)	LYGm2(CAYm5) (2012-13)
Number of students admitted in the corresponding First Year + admitted in 2nd year via lateral entry and separate division, if applicable	150	150	157
Number of students who have graduated without backlogs in the stipulated period	62	50	58
Success Index (SI)	0.41	0.33	0.37
Average SI	0.37		
=25×Average SI	9.25		

**Table B.4.2.1**

**4.2.2. Success Rate in Stipulated Period (15)**

SI= (Number of students who graduated from the program in the stipulated period of course duration)/ (Number of students admitted in the first year of that batch and admitted in 2nd year via lateral entry and separate division, if applicable)

Average SI = mean of Success Index (SI) for past three batches Success rate

**Success rate in stipulated period**

Item	LYG (CAYm3) (2014-15)	LYGm1(CAYm4) (2013-14)	LYGm2(CAYm5) (2012-13)
Number of students admitted in the corresponding First Year + admitted in 2nd year via lateral entry and separate division, if applicable	150	150	157
Number of students who have graduated in the stipulated period= 15 ×Average SI	102	106	123
Success Index (SI)	0.68	0.71	0.78
Average SI	0.72		
= 15 ×Average SI	10.80		

**Table B.4.2.2**

**4.3. Academic Performance in Third Year (15)**

Academic Performance = 1.5 \* Average API (Academic Performance Index)

API = ((Mean of 3rdYear Grade Point Average of all successful Students on a 10 point scale) or (Mean of the percentage of marks of all successful students in Third Year/10)) x (number of successful students/number of students appeared in the examination) Successful students are those who are permitted to proceed to the final year.



**Academic Performance in Third Year**

Academic Performance	CAY (2017-18)	CAYm1 (2016-17)	CAYm2 (2015-16)
Mean of CGPA or Mean Percentage of all successful students(X)	64.99	61.68	60.64
Total no. of successful students (Y)	134	146	149
Total no. of students appeared in the examination (Z)	134	146	149
API = X* (Y/Z)	6.499	6.168	6.064
Average API = (AP1 + AP2 + AP3)/3	6.244		
Academic Performance = 1.5 * Average API	1.5*6.244=9.366		

**Table B.4.3**

**4.4. Academic Performance in Second Year (15)**

Academic Performance Level = 1.5 \* Average API (Academic Performance Index)

API = ((Mean of 2ndYear Grade Point Average of all successful Students on a 10 point scale) or (Mean of the percentage of marks of all successful students in Second Year/10)) x (number of successful students/number of students appeared in the examination) Successful students are those who are permitted to proceed to the Third year.

**Academic Performance in Second Year**

Academic Performance	CAY (2017-18)	CAYm1 (2016-17)	CAYm2 (2015-16)
Mean of CGPA or Mean Percentage of all successful students(X)	62.64	60.56	58.87
Total no. of successful students (Y)	131	134	148
Total no. of students appeared in the examination (Z)	131	134	148
API = X* (Y/Z)	6.264	6.056	5.887
Average API = (AP1 + AP2 + AP3)/3	6.069		
Academic Performance Level = 1.5 * Average API	1.5*6.069=9.103		

**Table B.4.4**

## [SELF ASSESSMENT REPORT]



### 4.5. Placement, Higher Studies and Entrepreneurship (40)

Assessment Points = 40 x average placement

#### Placement, higher studies and entrepreneurship for past three years

Item	CAY (2017-18)	CAYm1 (2016-17)	CAYm2 (2015-16)
Total No. of Final Year Students (N)	146	149	151
No. of students placed in companies or Government Sector (x)	74	77	84
No. of students admitted to higher studies with valid qualifying scores (GATE or equivalent State or National Level Tests, GRE, GMAT etc.) (y)	2	3	8
No. of students turned entrepreneur in engineering/technology (z)	5	4	4
$x + y + z =$	81	84	96
Placement Index : $(x + y + z)/N$	0.56	0.56	0.64
Average placement = $(P1 + P2 + P3)/3$	0.58		
Assessment Points = 40 x average placement	23.39		

*Table B.4.5*

### 4.6. Professional Activities (20)

#### 4.6.1. Professional Societies/Chapters and Organizing Engineering Events (5)

##### List of Professional Societies/Chapters in Collaboration with the Department

S.No.	Name of the Professional Society
1	Mech-Tech Club

##### List of Professional Societies/ Organizing Engineering Events in CAY (2017-18)

S.No.	Name of Professional Societies / Chapters	Organized Event	Organized Period	Level of Event (Institute/ State/ National/ International)	Event Outcome	PO/PSO
1	Mech-Tech Club	Conference [NCFTME 2018]	March 25-26, 2018	National	Students and research scholars were made aware about the recent trends in the field of renewable energy	PO1,PO4,PO 10, PSO1,PSO2

## [SELF ASSESSMENT REPORT]



2	ISST	RITDME 2018 International conference	April 6-7, 2018	International	Students and research scholars were made aware about the field of RITDME.	PO1,PO4,PO10, PSO1,PSO2
3	NITTTTR, Chandigarh	Short term course on "Product Design and Development"	7-11 NOV. 2017	Institute	The entire program and the overall program was very satisfactory & learner-centric.	PO1,PO2,PO3,PO10,PO11,PO12,PSO2
4	Mech-Tech Club	TECH-FEST, 2018	25-28 March 2018	National	Techfest has provided platform to participate in innovative activities.	PO1,PO3,PO4,PO9,PO10,PO12,PSO1,PSO2
5.	SKYFI LABS	3-D Printing Workshop	25-26 October 2017	Institute	Students can create a 3D object in which layers of material are formed under computer control to create an object.	PO1,PO2,PO3,PO4,PO5,PSO2
6.	BAJA TUTOR	Workshop	1-2 Dec 2017	Institute	students got to know about complete knowledge of the automobiles	PO1,PO2,PO3,PO4,PO5,PO9,PO12,PSO1

### Technical Events Organized (Session 2015-16)

S. No.	Name of technical event	Level of event	Date	Outcomes	Relevance to POs
1	Embryo	National	18/02/2016	Student will be able to present paper and improve their communication skill.	PO1,PO4,PO10, <b>PSO1, PSO2</b>
2	Mightly Throttle	National	18/02/2016	Student will be able to enhance their knowledge of design of racing car.	PO1,PO3,PO5,PO9, <b>PSO1</b>
3	Propello	National	18/02/2016	Student will be able to know basic concept propulsion.	PO1,PO3,PO9
4	Cut 2 Design	National	19/02/2016	Student will be able to apply concept of Engineering	PO1,PO3

## [SELF ASSESSMENT REPORT]



				drawing.	
5	Fork Lifter	National	19/02/2016	Student will be able to build a crane model using wooden material suitable enough to place the given weights on a platform using only hydraulic mechanism.	PO1,PO3,P09, <b>PSO2</b>
6	Brain quest	National	19/02/2016	Student will be able to improve their technical and general knowledge.	PO1
7	R-Mech Olympiad	National	20/02/2016	Student will be able to improve their core technical subject's knowledge.	PO1
8	CADD mania	National	20/02/2016	Student will be able to improve their designing skill.	PO1,PO5, <b>PSO2</b>
9	Reverse Engineering	National	20/02/2016	Student will be able to enhance their knowledge of engine parts.	PO1,PO3,P09

### Technical Events Organized (Session 2016-17)

S #	Name of technical event	Level of event	Date	outcomes	Relevance to POs
1	Embryo	National	08/03/2017	Student will be able to present paper and improve their communication skill.	PO1,PO4,P010, <b>PSO1, PSO2</b>
2	Mightly Throttle	National	10/03/2017	Student will be able to enhance their knowledge of design of racing car.	PO1,PO3,P05,PO9, <b>PSO1</b>
3	Propello	National	11/03/2017	Student will be able to know basic concept propulsion.	PO1,PO3,P09,
4	Fork Lifter	National	11/03/2017	Student will be able to build a crane model using wooden material suitable enough to	PO1,PO3,P09, <b>PSO1</b>

## [SELF ASSESSMENT REPORT]



				place the given weights on a platform using only hydraulic mechanism.	
5	Brain quest	National	09/03/2017	Student will be able to improve their technical and general knowledge.	PO1
6	R-Mech Olympiad	National	10/03/2017	Student will be able to improve their core technical subject's knowledge.	PO1
7	CADD mania	National	08/03/2017	Student will be able to improve their designing skill.	PO1,PO5, <b>PSO2</b>
8	Reverse Engineering	National	09/03/2017	Student will be able to enhance their knowledge of engine parts.	PO1,PO3,P O9

### Technical Events Organized (Session 2017-18)

S.N o.	Name of technical event	Level of event	Date	Outcomes	Relevance to POs
1	Embryo	National	25 - 26 March 2018	Student will be able to present paper and improve their communication skill.	PO1,PO4,P O10, <b>PSO1</b> , <b>PSO2</b>
2	Mighty Throttle	National	26-03-2018	Student will be able to enhance their knowledge of design of racing car.	PO1,PO3,P O5,PO9, <b>PSO1</b>
3	Propello	National	28-03-2018	Student will be able to know basic concept propulsion.	PO1,PO3,P O9
4	Cut 2 Design	National	27-03-2018	Student will be able to apply concept of Engineering drawing.	PO1,PO3
5	Fork Lifter	National	28-03-2018	Student will be able to build a crane model using wooden material suitable enough to place the given	PO1,PO3,P O9, <b>PSO1</b>



## [SELF ASSESSMENT REPORT]



				weights on a platform using only hydraulic mechanism.	
6	Brain quest	National	26-03-2018	Student will be able to improve their technical and general knowledge.	PO1
7	R-Mech Olympiad	National	27-03-2018	Student will be able to improve their core technical subject's knowledge.	PO1
8	Cadd mania	National	25-03-2018	Student will be able to improve their designing skill.	PO1,PO5, <b>PSO2</b>

### List of Professional Societies/ Organizing Engineering Events in CAYm1 (2016-17)

S. No	Name of Professional Societies / Chapters	Organized Event	Organized Period	Level of Event (Institute/ State/ National/ International)	Event Outcome	PO/PSO
1	ISST,Gaziabad	Conference [RESSD-2016]	07-08 October, 2016	National	Students and research scholars were made aware about the recent trends in the field of renewable energy	PO1,PO4,PO10 ,PSO1,PSO2
2	NITTTR,Chandigarh	Department of Mechanical Engineering organized an ICT based short term course on "New Manufacturing Technologies" in association with NITTTR Chandigarh	07-11 November, 2016	National	Faculty members gained extensively details of new materials, manufacturing technologies, manufacturing processes	PO1,PO2,PO3, PO10,PO11,PO 12,PSO2
3	Mech-Tech Club	TECH FEST2017	06-11 March 2017	National	Tech fest has provided platform	PO1,PO3,PO4, PO9,PO10,PO1

## [SELF ASSESSMENT REPORT]



						2,PSO1,PSO2
4	Cadd Centre	ANSYS Training Programme	05-07 March, 2017	Institute	Knowledge about software	PO1,PO2,PO3, PO4,PO5,PO12, PSO2
5	Engineers Academy	Guest Lecture on Career Counselling	29 August 2016	Institute	Extra knowledge about subject	PO6,PO8,PO9, PO10,PO12
6.	Baba Automobiles	Guest Lecture on Introduction to Various Types of Automobile Engines	01 October 2016	Institute	Knowledge about Automobile Engines	PO1,PO2,PO3, PO4,PO5, PO12,PSO1
7.	Baba Automobiles	Work Shop on Assembling and Disassembling of 2 & 4 Stroke Engines	15-19 November 2016	Institute	Knowledge about 2 & 4 Stroke Engines	PO1,PO2,PO3, PO4,PO5, PO12,PSO1

### 4.6.2. Publication of Technical Magazines, Newsletters, etc. (5)

#### List of Publication of Newsletters

S. No.	Academic Year	Name of The Newsletter	Month and Year of Publication	Name of editors	Name of Publishers	PO/PSO
1	2017-18	The Mechanical news	Every Month	Ms. Palak Jindal, Mr. YogeshDubey	Mechanical Department	PO10,PO12
2	2016-17	The Mechanical news	Every Month	Ms. Palak Jindal, Mr. YogeshDubey	Mechanical Department	PO10,PO12



# E-MECHZINE



FIRST ISSUE

JULY-DECEMBER 2016



PROMULGATION



COLLOQUIUM



PATHMAKER LEAGUE



TECHNOCRATZ



JUKE BOX



DEPARTMENT OF MECHANICAL ENGINEERING  
JAIPUR ENGINEERING COLLEGE AND RESEARCH CENTRE



JAIPUR ENGINEERING COLLEGE  
AND RESEARCH CENTRE



## Inside Stories

INTERNATIONAL CONFERENCE

ISRO Exhibition

Faculty Publications

# April-2018

## Department of Mechanical Engineering

Accelerating the Creativity of Mechanical Engineers



## [SELF ASSESSMENT REPORT]



### List of Publication of Technical Magazines

S. No.	Academic Year	Name of The Technical Magazines	Month and Year of Publication	Name of editors	Name of Publishers	PO/PSO
1	2017-18	E-MECHZINE	Every Six Month	Ms. Palak Jindal, Mr. Yogesh Dubey Mr. Lalit Kumar Sharma	Mechanical Department	PO1,PO10, PO12
2	2016-17	E-MECHZINE	Every Six Month	Ms. Palak Jindal, Mr. Yogesh Dubey Mr. Lalit Kumar Sharma	Mechanical Department	PO1,PO10, PO12

#### 4.6.3. Participation in Inter-Institute Events by Students of the Program of Study (10)

##### Participation in Inter-Institute Events by Students in CAY (2017-18)

S.No.	Name/No. of students	Event	Date	Organized by	Event outcomes	PO/PSO
1	23 students	The Moto rids”	17/03/2018	NKRC Season-4	“Stig Award” and “Rs 10000” cash reward.	PO1,PO2,PO3,PO4,PO5,PO9,PO10,PO11,PO12,PSO1,PSO2
2	32 students	Moon Riders JECRC @ N K R C	29/9/17- 5/10/17	Radharamn Engg. College, Bhopal	performed very well	PO1,PO2,PO3,PO4,PO5,PO9,PO10,PO11,PO12,PSO1,PSO2
3	20 students	Go-Kart	11.01.18 to 15.01.18	Kolhapur under SAE	performed very well	PO1,PO2,PO3,PO4,PO5,PO9,PO10,PO11,PO12,PSO1,PSO2
4.	PankajMahris hi&Yadunand anGautam	Geeta Gyan Pratiyogita	2018	SKIT,Jaipur	students got 2nd position	PO10,PO9



Technical Event: **NKRC Season - 4**

Description: GO-KART

Date:08/07/17-09/7/17



Technical Event: **Moon Riders JECRC**

Description: Go Kart Racing

Date:29/9/17-3/10/17

## [SELF ASSESSMENT REPORT]



Technical Event: **Geeta Gyan Pratiyogita @ SKIT 2018**

Description: **Geeta Gyan Pratiyogita**

Date: 21/02/18

### Participation in Inter-Institute Sports Events by Students in CAY (2017-18)

S.No	Name of students	Event	Sport	Date	Organized by	Position	PO/PSO
1	Yeeshu Dwivedi	RTU Inter-College Tournament	Chess	12-14 September 2017	Pacific Business School, Udaipur	Runner up	PO8,PO9
2	Manish, Hemant, Dhruv, Rajat, Shubham, Pankaj & Luvkesh	BITS Open Sports Meet 2017	Swimming	21-25 September	BITS Pilani	won second position in 200m free style stroke	PO8,PO9
3	Aditya Sharma & Sourabh Gupta	RTU Inter-College Tournament	Badminton	02/09/2017 to 07/09/2017	RTU	1 <sup>st</sup> Position	PO8,PO9



Technical Event: **BITS Open Sports Meet 2017**

Description: **Swimming**

Date: 21/09/17



Technical Event: **RTU Badminton Tournament**

Description: **Badminton**

Date: 02/09/17



## [SELF ASSESSMENT REPORT]



Technical Event: **RTU Badminton Tournament**

Description: **Badminton**

Date: 02/09/17

### Participation in Inter-Institute Events by Students in CAYm1 (2016-17)

S.No.	Name of students	Event	Date	Organized by	Event outcomes	PO/PSO
1	Mr. Harshul Khandelwal, Mr. Aditya Yadav, Mr. Gaurav Lodha, Mr. Bhupendra Suman	Robowar	01-04 September 2016.	IIT Guwahati	secured 8 <sup>th</sup> Position	PO1,PO2,P03,PO9,P011
2	Mr. Pankaj Maharshi, Mr. Pankaj Sharma, Mr. Yash Sharma, Mr. Divyank Rathi, Mr. Sourabh Gupta, Mr. Yashwant Khandelwal, Mr. Himank Dave, Mr. Yeeshu Dwivedi and Mr. Rajat Shrivastav	Automobile Mechanics & IC Engine in "RENDEZVOUS"	21-24 October 2016	IIT Delhi	participate	PO1,PO2,P03,PO4,P05,PO12,P01
3	Sourabh Mangal and Satyam Jain	MESH FLARE	16-18 Dec. 2016	IIT Bombay	Participate	PO1,PO2,P03,PO4,P05,PO9,P011,PSO2
4	Harshul Khandelwal	ROBOWA	LNMIT	18 <sup>th</sup> to 20 <sup>th</sup>	won 2 <sup>nd</sup>	PO1,PO2,P

## [SELF ASSESSMENT REPORT]



		R		Jan, 2017	prize	O3,PO9,P O11
5	GouravLodha	RC Car event	at Baba Farid College of Engineering & Technology, Bhatinda	27 <sup>th</sup> to 30 <sup>th</sup> Jan 2017.	Participate	PO1, PO2,PO3,P O5,PO9,PS O1,
6	Mr. ArpitNatani (III Year) and Arpit Agarwal (III Year)	RC car	RTU, Kota	15 <sup>th</sup> -18 <sup>th</sup> February 2017	won 2 <sup>nd</sup> prize	PO1, PO2,PO3,P O5,PO9,PS O1,
7	Moonrider Club of JECRC	Go Cart event “	Elite Carting” at Bhopal	14 <sup>th</sup> to 20 <sup>th</sup> February 2017	participate d	PO1,PO2,P O3,PO4,P O5,PO9,P O10,PO11, PO12,PSO 1,PSO2
8	A team of 5 students	RC Car event	MIT and DY Patil, Pune	6 <sup>th</sup> to 11 <sup>th</sup> February 2017	participate d	PO1, PO2,PO3,P O5,PO9,PS O1,



Technical Event: **Robowar**

Description: IIT Guwahati

Date: 01-04 Sept.2016



Technical Event: **Robowar**

Description: IIT Guwahati

Date: 01-04 Sept.2016



Technical Event: **RENDEZVOUS - IIT Delhi**

Description: **Automobile Mechanics & IC Engine**

Date: 21-24 Oct.2016

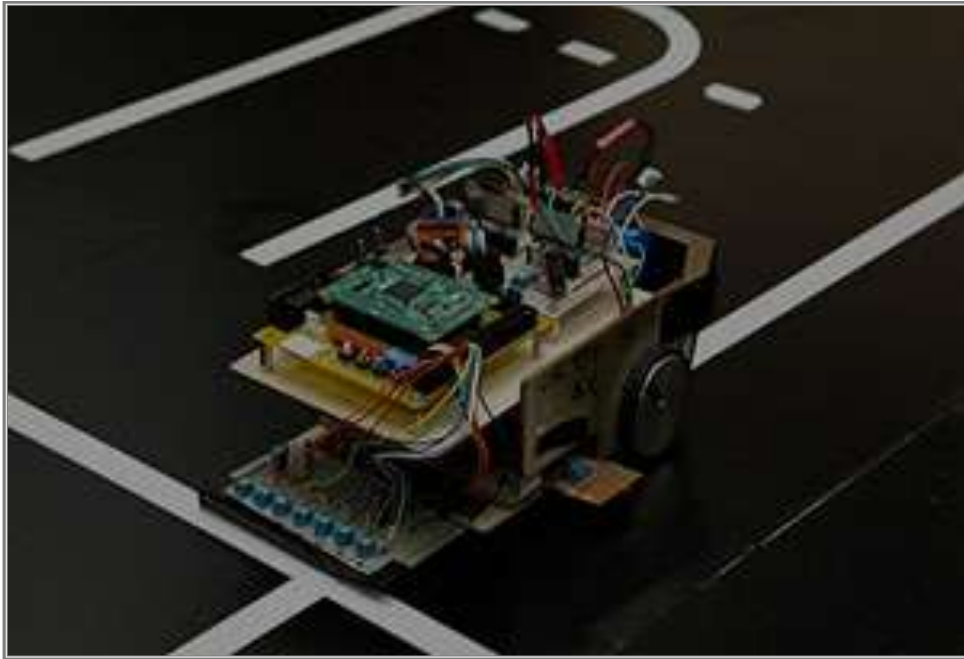

Technical Event: **Mesh Flare**

Description: **Techfest – IIT Bombay**

Date: 16-18 Dec.2016



Technical Event: **RoboWar**

Description: **RoboWar**

Date: 18-20 Jan 2017



Technical Event: **Vibgyor**

Date: 28-29 Jan 2017



Technical Event: **RC Car Event**

Description: **RC Car**

Date: 06-11 Feb 2017



Technical Event: **RC Car Event**

Description: **RC Car**

Date: 06-11 Feb 2017



Technical Event: **Elite Carting**

Description: **Bhopal**

Date: 14-20 Feb 2017

## [SELF ASSESSMENT REPORT]



### Participation in Inter-Institute Sports Events by Students in CAYm1 (2016-17)

S.No	Name of students	Event	Sport	Date	Organized by	Position	PO/PSO
1	Yeeshu Dwivedi, Dhruv Laddha	Inter College Tournament of RTU	Chess	22-24 August 2016.	Poornima College of Engineering	won first prize	PO8,PO9
2	RajatShrivastav	National Level Competition	Swimming	15-19 September 2016.	BITS, Pilani	won Silver Medal in Freestyle-100m and Bronze Medal in Freestyle-400m	PO8,PO9
3.	Shobit Yadav , Himanshu Acharya	RTU	Football	27 <sup>th</sup> October 2016	Arya College of Engineering	team won the RTU Football Tournament	PO8,PO9
4	Aditya Sharma& Saurabh Gupta	VANQUI SH	badminton	24 <sup>th</sup> march to 26 <sup>th</sup> march	Global Technical Campus	won first prize	PO8,PO9



Technical Event: **Chess**

Description: First Position(Poornima Jaipur)

Date:22-24 Aug. 2016



Technical Event: **Winner in Swimming Competition s**

Description: BITS

Date:15-19sept 2016



Technical Event: **RTU Football Winners**

Description: BITS

Date:27 Oct. 2016





Technical Event: **Badminton**

Description: BITS

Date:24-26 March 2016

Participation in Inter-Institute Sports Events by Students in CAYm2 (2015-16)

S.No.	Name of students	Event	Sport	Date	Organized by	Position	PO/PSO
1	Abhimanyu singhBhati	Sports-Fest	Gali - Football	2015	Kautilya, Jaipur	Ist Position	PO8,PO9
2	Deepak totlani,Arnim vijay+2	Sports-Fest	Cricket	29Oct,1 Nov.2015	IIT, Jodhpur	Semifinal	PO8,PO9

## [SELF ASSESSMENT REPORT]



### Participation in Inter-Institute Events by Students in CAYm2 (2015-16)

S.No.	Name of students	Event	Date	Organized by	Event outcomes	PO/PSO
1.	Abhimanyu Singh Bhati, Anshulkhandelwal, Mradul Agarwal	Virtual Baja SAE India - 2015	10&11 July 2015	Chitkara university punjab	Participation	PO1,PO2,PO4,PO5,PO9, PO12,PSO1, PSO2
2.	Arun Yadav, Anurag Verma	EFFI-CYCLE, 2015	4&5 July 2015	KIET, Gagiya	Participation	PO1,PO2,PO3,PO4,PO5, PO9,PO11,PO12,PSO1,PSO2
3	Adil Ahamed Fariki, Aman Gupta, Akshay Kumarsoni, Akshay Kirti Sharma	SAE-INDIA, Student Convention	10 Oct. 2015	SKIT, Jaipur	Participation	PO1,PO2,PO10,PO12,PSO1
4.	Amit Modi, Akash Jain	Esuemit 2015	28-30 Aug. 2015	IIT, Kanpur	Participation	PO11
5	Abhishek Bhardwaj,	Full throttle grand prix	25-29 March 2015	BITS PLANI	Ist, position	PO1, PO2,PO3,PO5,PO9,PSO1
6	Abhimanyu Singh Bhati	Robo-War	25-29 March 2015	BITS PLANI	I <sup>st</sup> , position	PO1,PO2,PO3,PO9,PO11
7	Mohit	Dance, X-	9 to 10	Gyanviha	II <sup>nd</sup> Position	PO9

## [SELF ASSESSMENT REPORT]



	Yadav	Animo-2015	Oct. 2015	r		
8	Kapil Sharma	National Conferance	13-14 March 2015	JIMS, Jaipur	Participation	PO1,PO4,PO 10,PSO1,PS O2
9	PriteshCha ndhok,Roh an Sharma, AnuragVer ma,ArunYa dav	Efficycle- 2015	15-18 Oct. 2015	Lovely Professio nal university ,punjab	Participation	PO1,PO2,PO 3,PO4,PO5, PO9,PO11,P O12,PSO1,P SO2

### List of publications by students

S.No.	Academic Year	No of Publications by Students in Journals	No of Publications by Students in Conference
1	2017-18	N/A	39
2	2016-17	16	26

### Consolidated Students Participation in inter-institute events

Description	No. of Students Participated		
	CAY (2017-18)	CAYm1(2016-17)	CAYm2(2015-16)
Within the State	40	30	35
Outside State	96	100	30
Prize/Awards Received	26	42	04

## [SELF ASSESSMENT REPORT]



### Participation in Inter-Institute Events by Students in CAY (2017-18)

S.No.	Name/No. of students	Event	Date	Organized by	Event outcomes	PO/PSO
1	MOHIT MENARIA LAVNEET JHASAL DEVENDRA KUMAR VIJAY KRISHNA AGARWAL KISHAN KUMAWAT JAYANT SATI DATTATREHY SINGH SHEKHAWAT USAMA SHERWANI VIKASH JAIN DEEPAK CHOUDHARY SHUBHAM WADHWA PRINCE KUMAR SHARMA GOVIND SAINI YASH DANGI VIKRAM PRATAP SINGH SUMIT JAIN SAKSHAM SONI PANKAJ JANGID ADITYA AGARWAL VIKAS JAIN SHUBHAM WADHWA ANUJ TIWARI GOVIND SAINI	The Moto rids”	17/032018	NKRC <i>Season-4</i>	“ <i>Stig Award</i> ” and “ <i>Rs 10000</i> ” cash reward.	PO1,PO2,PO3,PO4 ,PO5,PO9,PO10,P O11,PO12,PSO1,P SO2

## [SELF ASSESSMENT REPORT]



2	DEEPAK KURUP ANIRUDH SINGH CHOUHAN GOVIND SAINI ANUJ TIWARI KISHAN KUMAWAT PRATYUSH BHARDWAJ HARSHIL PANDIT SAKSHAM SONI PAWAN KUMAR SUTHAR HIMANSHU BANSAL PARUL YADAV MANISH KUMAR SHAMRA ABHIJEET SHARMA JITENDRA DEVNANI DEEPAK SHARMA HARSH MANTRI BHARAT PURSNANI ABHIJEET SINGH RATHORE PRINCE KUMAR SHARMA AJAY JADAM PIYUSH PURSNANI NAMAN VIJAYVARGIYA SHUBHAM WADHWA SAURABH SINGH ADITYA AGARWAL ABHISHEK KUMAR MOHSIN KHAN MD.AMAN LUHAR	Moon Riders JECRC @ N K R C	29/9/17- 5/10/17	Radharamn Engg. College, Bhopal	performed very well	PO1,PO2,PO3,PO4 ,PO5,PO9,PO10,P O11,PO12,PSO1,P SO2
---	--	---	---------------------	--	------------------------	--

## [SELF ASSESSMENT REPORT]



	MOHIT VAISHNAV MANISH SAINI VIKASH JAIN MOHIT NAGPAL					
3	MANISH SAINI ADITYA UPADHYAY ABHISHEK KUMAR HARSHIL PANDIT JAIDEEP MAHENDRA HARSHIT JAIN DEEPAK MITTAL ASHUTOSH DADHICH JITENDRA DEYNANI HIMASNSHU PAGARIYA HIMANSHU JANGIR MIHIR PANCHAL VIKAS YADAV RISHABH GOYAL BHANU PRAKASH GUPTA CHANDRA PRAKASH FULUEANI DEVENDRA PRATAP YADAV AKSHAY KUMAR ANURUDH SINGH ARJUN SINGH DEORA	Go-Kart	11.01.18 to 15.01.18	Kolhapur under SAE	performed very well	PO1,PO2,PO3,PO4 ,PO5,PO9,PO10,P O11,PO12,PSO1,P SO2
4.	Pankaj Mahrishi & Yadunandan Gautam	GEETA GYAN PRATIY OGITA	2018	SKIT, Jaipur	students got 2nd position	PO10,PO9

# [SELF ASSESSMENT REPORT]



<b>CRITERION 5</b>	<b>Faculty Information and contribution</b>	<b>200</b>
--------------------	---	------------

## 5. FACULTY INFORMATION AND CONTRIBUTION (200)

Faculty information for three assessment year

Faculty Information (Session 2018- 19)

Name of the Faculty Member	Pan Card Number	Qualification			Association with the Institution	Designation	Date on which Designated as Professor/ Associate Professor	Date of Joining the Institution	Department	Specialization	Academic Research			(In case Currently Associated is ("No") Date of Leaving Currently Associated (Y/N)	Nature of Association (Regular/Contract)
		Degree (highest degree)	University	Year of attaining higher qualification							Research Paper Publications	Ph.D. Guidance	Faculty Receiving Ph.D. during the Assessment Years		
Manish Jain	AANPJ7357E	M.Tech	MNIT	2005	17 Years 2 Months	Associate Professor		7-Aug-01	ME	Manufacturing Systems Engineering	0	Nil	NO	Y	Regular
Lalit Kumar Sharma	BQSPS3044K	M. Tech	MNIT	2013	11 Years 02 Months	Assistant Professor		13-Aug-07	ME	Manufacturing Systems Engineering	0	Nil	NO	Y	Regular
Rajendra Kumar Gupta	AGVPG7205J	M.Tech	Jagannath University	2014	11 Years 01 Months	Assistant Professor		17/Sep/07	ME	Manufacturing Systems Engineering	0	Nil	NO	Y	Regular
Kuldeep Sharma	BKOPSS002H	M.Tech	MJRP	2014	12 Years 02 Months	Assistant Professor		25-Aug-06	ME	Manufacturing Systems Engineering	0	Nil	NO	Y	Regular

## [SELF ASSESSMENT REPORT]



Aashish Nagpal	AUYPN8399M	M.Tech	Jagannath University	2014	8 Years 02 Months	Assistant Professor		16-Aug-10	ME	Manufacturing Systems Engineering	0	Nil	NO	Y	Regular
Nikhil Jain	ARJPJ7522J	M.Tech	Jagannath University	2015	6 Years 8 Months	Assistant Professor		16-Feb-12	ME	Production Engineering	0	Nil	NO	Y	Regular
Dayal Singh Rathore	ARZPR1164L	M.Tech	Jagannath University	2015	6 Years 03 Months	Assistant Professor		23-Jul-12	ME	Production Engineering	0	Nil	NO	Y	Regular
Hukam Chand Nagar	AXAPC7807L	M.Tech	Jagannath University	2017	6 Years 03 Months	Assistant Professor		23-Jul-12	ME	Thermal Engineering	0	Nil	NO	Y	Regular
Akhil Vijay	AHJPV3272D	M.Tech	Jagannath University	2016	6 Years 03 Months	Assistant Professor		24-Jul-12	ME	Production Engineering	0	Nil	NO	Y	Regular
Abhishek Kumar	BVBPK2936A	M.Tech	Jagannath University	2014	5 Years 02 Months	Assistant Professor		10-Aug-13	ME	Manufacturing Systems Engineering	0	Nil	NO	Y	Regular
Satyendra Kumar	BSKPK2741R	M.Tech	RTU, Kota	2014	4 Years 02 Months	Assistant Professor		16-Jul-14	ME	Machine Design	0	Nil	NO	Y	Regular



## [SELF ASSESSMENT REPORT]



Dr. Manish Shrivastava	ARUPS7035A	M.Tech/Phd (MBA)	Jagannath University	2014	4 Years 03 Months	Associate Professor	1-9-2018	21-Jul-14	ME	Manufacturing Systems Engineering	0	Nil	NO	Y	Regular
Veerendra Kumar	CKGPK4471D	M.Tech	NIT Jalandhar	2014	3 Years 1 Month	Assistant Professor		3-Jul-15	ME	Mechanical Engineering	0	Nil	NO	7-8-18	Regular
Dr. Bhuvnesh Bhardwaj	AONPB5285K	Phd	SLITE	2016	3 Years 3 Months	Associate Professor		14-Jul-15	ME	Manufacturing Systems Engineering	0	Nil	Yes	Y	Regular
Tejendra Singh	ANEPT2083P	M.Tech	Jagannath University	2014	2 Years 9 Months	Assistant Professor		4-Jan-16	ME	Manufacturing Systems Engineering	0	Nil	NO	Y	Regular
Satyaprakash Saini	BJQPS8962K	M.Tech	MNIT	2015	2 Years 9 Months	Assistant Professor		20-Jan-16	ME	Metallurgical and material Engineering	0	Nil	NO	Y	Regular
Gaurav Jain	BEUPJ6288J	M.Tech	MNIT	2016	2 Years 3 Months	Assistant Professor		21-Jul-16	ME	Industrial Engineering	0	Nil	NO	Y	Regular
Shashank Shekhar Singh	DKXPS5394K	M.Tech	AMU	2016	2 Years 3 Months	Assistant Professor		1-Jul-16	ME	Machine Design	0	Nil	NO	Y	Regular
Shrikant Bansal	AZWPB3081B	M.Tech	MNIT	2016	2 Years 2 Months	Assistant Professor		1-Aug-16	ME	Industrial Engineering	0	Nil	NO	Y	Regular
Dr. M P Singh	AOPPS5028F	M.tech/Ph.D	MNIT /Jagannath University	2014	2 Years 02 Months	Professor		19-Aug-16	ME	Mechanical Engineering	0	Nil	NO	Y	Regular

## [SELF ASSESSMENT REPORT]



Tejbahadur Singh	CMQPS7636J	M.Tech	NIT Jalandhar	2015	1 Years 9 Months	Assistant Professor		2-Jan-17	ME	Mechanical Engineering	0	Nil	NO	Y	Regular
Priti P. Bodkhe	ATVPB1700A	M.Tech	Pune University	2016	1 Years 9 Months	Assistant Professor		3-Jan-17	ME	Heat and Power Engineering	0	Nil	NO	Y	Regular
Palak Jindal	AMHPN6656J	M.Tech	Kurukshetra University	2014	1 Years 9 Months	Assistant Professor		4-Jan-17	ME	Production & Industrial Engineering	0	Nil	NO	Y	Regular
Hemant Bansal	APGPB2872J	M.Tech	RTU, Kota	2016	1 Years 9 Months	Assistant Professor		2-Jan-17	ME	Production Engineering	0	Nil	NO	Y	Regular
AkhileshPaliwal	CPSP3593N	M.Tech	NIT Jalandhar	2014	1 Years 9 Months	Assistant Professor		3-Jan-17	ME	Industrial and Management Engineering	0	Nil	NO	Y	Regular
Manmohan Siddh	BNPPS2864D	M.Tech	RTU, Kota	2012	1 Years 9 Months	Assistant Professor		2-Jan-17	ME	Production Engineering	0	Nil	NO	Y	Regular
Yogesh Dubey	AVGPD6643R	M.Tech	Jagannath University	2014	1 Years 8 Months	Assistant Professor		8-Feb-17	ME	Manufacturing Systems Engineering	0	Nil	NO	Y	Regular
Tejaram Saini	GEWPS4834A	M.Tech	SVNIT	2015	11 Months	Assistant Professor		1-Sep-17	ME	Turbomachines	0	Nil	NO	8-8-18	Regular
Rohit Goyal	BBYPG5272N	M.Tech	VIT	2016	9 Months	Assistant Professor		18-Jan-18	ME	Mechatronics	0	Nil	NO	Y	Regular
Utpal Chakravarty	AAHPC5325R	M.Tech	NIMS	2013	1 Years 08 Month	Professor		16-Feb-17	ME	Industrial Engineering	0	Nil	NO	Y	Regular

## [SELF ASSESSMENT REPORT]



Dr. Fauzia Siddiqui	BHAPS1199C	M.tech/Ph.D	IP University	2015	2 Months	Professor		1-8-2018	ME	Industrial Engineering	0	Nil	NO	Y	Regular
Dr. Rishi Pareek	AYAPP6684K	M.tech/Ph.D	SVNIT	2018	2 Months	Associate Professor		7-8-2018	ME	Mechanical Engineering	0	Nil	NO	Y	Regular
Devesh Kumar	CGEPK1495D	M.Tech	MNIT	2014	2 Months	Assistant Professor		2-8-2018	ME	Material Science	0	Nil	NO	Y	Regular
Ravindra Kumar	BIVPK3417P	M.Tech	Bits Ranchi	2012	2 Months	Assistant Professor		7-8-2018	ME	Heat power Engineering	0	Nil	NO	Y	Regular
Neeraj Saini	DVOPS1723Q	M.Tech	MNIT	2012	2 Months	Assistant Professor		10-8-18	ME	Manufacturing System	0	Nil	NO	27-9-18	Regular
Ravi Yadav	CFUPR3176R	B.Tech,M.Tech (Pur)	RTU	2012	6 Years 2 months	Assistant Professor		27-7-2012	ME	Mechanical Engineering	0	Nil	NO	Y	Regular

**Table B.5a**

# [SELF ASSESSMENT REPORT]



## Faculty Information (Session 2017- 18)

Name of the Faculty Member	Pan Card Number	Qualification			Association with the Institution	Designation	Date on which Designated as Professor/ Associate Professor	Date of Joining the Institution	Department	Specialization	Academic Research			(In case Currently Associated is ("No") Date of Leaving Currently Associated (Y/N)	Nature of Association (Regular/Contract)
		Degree (highest degree)	University	Year of attaining higher qualification							Research Paper Publications	Ph. D. Guidance	Faculty Receiving Ph.D. during the Assessment Years		
Manish Jain	AANPJ7357E	M.Tech	MNIT	2005	17 Years 2 Months	Associate Professor	01/Oct/17	7-Aug-01	ME	Manufacturing Systems Engineering	5	Nil	NO	Y	Regular
Lalit Kumar Sharma	BQSPS3044K	M. Tech	MNIT	2013	11 Years 02 Months	Assistant Professor		13-Aug-07	ME	Manufacturing Systems Engineering	6	Nil	NO	Y	Regular
Rajendra Kumar Gupta	AGVPG7205J	M.Tech	Jagannath University	2014	11 Years 01 Months	Assistant Professor		17/Sep/07	ME	Manufacturing Systems Engineering	4	Nil	NO	Y	Regular
Kuldeep Sharma	BKOPS5002H	M.Tech	MJRP	2014	12 Years 02 Months	Assistant Professor		25-Aug-06	ME	Manufacturing Systems Engineering	5	Nil	NO	Y	Regular
AashishNagpal	AUYPN8399M	M.Tech	Jagannath University	2014	8 Years 02 Months	Assistant Professor		16-Aug-10	ME	Manufacturing Systems Engineering	3	Nil	NO	Y	Regular
Nikhil Jain	ARJPJ7522J	M.Tech	Jagannath University	2015	6 Years 8 Months	Assistant Professor		16-Feb-12	ME	Production Engineering	5	Nil	NO	Y	Regular

## [SELF ASSESSMENT REPORT]



Dayal Singh Rathore	ARZPR1164L	M.Tech	Jagannath University	2015	6 Years 03 Months	Assistant Professor		23-Jul-12	ME	Production Engineering	3	Nil	NO	Y	Regular
Hukam Chand Nagar	AXAPC7807L	M.Tech	Jagannath University	2017	6 Years 03 Months	Assistant Professor		23-Jul-12	ME	Thermal Engineering	2	Nil	NO	Y	Regular
Akhil Vijay	AHJPV3272D	M.Tech	Jagannath University	2016	6 Years 03 Months	Assistant Professor		24-Jul-12	ME	Production Engineering	4	Nil	NO	Y	Regular
Ravindra Singh Yadav	AJHPY2527J	M.Tech	Jagannath University	2017	6 Years 03 Months	Assistant Professor		24/Aug/12	ME	Manufacturing Systems Engineering	2	Nil	NO	10.02.2018	Regular
Abhishek Kumar	BVBPK2936A	M.Tech	Jagannath University	2014	5 Years 2 Months	Assistant Professor		10-Aug-13	ME	Manufacturing Systems Engineering	4	Nil	NO	Y	Regular
Satyendra Kumar	BSKPK2741R	M.Tech	RTU,Kota	2014	4 Years 3 Months	Assistant Professor		16-Jul-14	ME	Machine Design	7	Nil	NO	Y	Regular
Vipin Goyal	AKFPG4807Q	M.Tech	IIT Roorkee	2014	3 Years 9 Months	Assistant Professor		18/Jul/14	ME	Industrial Metallurgy	4	Nil	NO	31.03.2018	Regular
Dr. Manish Shrivastava	ARUPS7035A	M.Tech/Phd (MBA)	Jagannath University	2014	4 Years 3 Months	Assistant Professor		21-Jul-14	ME	Manufacturing Systems Engineering	4	Nil	NO	Y	Regular
Veerendra Kumar	CKGPK4471D	M.Tech	NIT Jalandhar	2014	3 Years 1 Months	Assistant Professor		3-Jul-15	ME	Mechanical Engineering	3	Nil	NO	Y	Regular
Dr. Bhuvnesh Bhardwaj	AONPB5285K	Phd	SLITE	2016	3 Years 3 Months	Associate Professor		14-Jul-15	ME	Manufacturing Systems Engineering	12	Nil	Yes	Y	Regular

## [SELF ASSESSMENT REPORT]



Md. InzamamUIHaque	AMQPH7828H	M.Tech	RTU Kota	2017	2 Years 9 Months	Assistant Professor		29-7-15	ME	Thermal Engineering	3	Nil	NO	18.04.2018	Regular
Tejendra Singh	ANEPT2083P	M.Tech	Jagannath University	2014	2 Years 9 Months	Assistant Professor		4-Jan-16	ME	Manufacturing Systems Engineering	2	Nil	NO	Y	Regular
Satyaprakash Saini	BJQPS8962K	M.Tech	MNIT	2015	2 Years 9 Months	Assistant Professor		20-Jan-16	ME	Metallurgical and material Engineering	3	Nil	NO	Y	Regular
AnanyaChattree	BFSPC5580H	M.Tech	IIT Roorkee	2015	2 Years 9 Months	Assistant Professor		04/Jan/16	ME	Production & Industrial Engineering	1	Nil	NO	27-12-2017	Regular
Gaurav Jain	BEUPJ6288J	M.Tech	MNIT	2016	2 Years 3 Months	Assistant Professor		21-Jul-16	ME	Industrial Engineering	2	Nil	NO	Y	Regular
Shashank Shekhar Singh	DKXPS5394K	M.Tech	AMU	2016	2 Years 3 Months	Assistant Professor		1-Jul-16	ME	Machine Design	3	Nil	NO	Y	Regular
Shrikant Bansal	AZWPB3081B	M.Tech	MNIT	2016	2 Years 2 Months	Assistant Professor		1-Aug-16	ME	Industrial Engineering	3	Nil	NO	Y	Regular
Dr. M P Singh	AOPPS5028F	M.tech/Ph.D	MNIT /Jagannath University	2014	2 Years 2 Months	Professor		19-Aug-16	ME	Mechanical Engineering	11	Nil	NO	Y	Regular
Tejbahadur Singh	CMQPS7636J	M.Tech	NIT Jalandhar	2015	1 Years 9 Months	Assistant Professor		2-Jan-17	ME	Mechanical Engineering	3	Nil	NO	Y	Regular
Priti P. Bodkhe	ATVPB1700A	M.Tech	Pune University	2016	1 Years 9 Months	Assistant Professor		3-Jan-17	ME	Heat and Power Engineering	1	Nil	NO	Y	Regular
Palak Jindal	AMHPN6656J	M.Tech	Kurukshetra University	2014	1 Years 9 Months	Assistant Professor		4-Jan-17	ME	Production & Industrial Engineering	2	Nil	NO	Y	Regular

## [SELF ASSESSMENT REPORT]



Hemant Bansal	APGPB2872J	M.Tech	RTU, Kota	2016	1 Years 9 Months	Assistant Professor		2-Jan-17	ME	Production Engineering	3	Nil	NO	Y	Regular
Akhilesh Paliwal	CPSP3593N	M.Tech	NIT Jamshedpur	2014	1 Years 9 Months	Assistant Professor		3-Jan-17	ME	Industrial and Management Engineering	3	Nil	NO	Y	Regular
Manmohan Siddh	BNPPS2864D	M.Tech	RTU,Kota	2012	1 Years 9 Months	Assistant Professor		2-Jan-17	ME	Production Engineering	2	Nil	NO	Y	Regular
Yogesh Dubey	AVGPD6643R	M.Tech	Jagannath University	2014	1 Years 8 Months	Assistant Professor		8-Feb-17	ME	Manufacturing Systems Engineering	3	Nil	NO	Y	Regular
Tejaram Saini	GEWPS4834A	M.Tech	SVNIT	2015	11 Months	Assistant Professor		1-Sep-17	ME	Turbomachines	0	Nil	NO	Y	Regular
Rohit Goyal	BBYPG5272N	M.Tech	VIT	2016	9 Months	Assistant Professor		18-Jan-18	ME	Mechatronics	0	Nil	NO	Y	Regular
Utpal Chakravarty	AAHPC5325R	M.Tech	NIMS	2013	1 Years 08 Months	Professor		16-Feb-17	ME	Industrial Engineering	0	Nil	NO	Y	Regular
Dr. M.S. Sodhi	ACRPS7035C	Ph.D	IIT, Kanpur	1981	3 Years 4 Months	Professor	18-Feb-15	18-Feb-15	ME	Metallurgy Engineering	12	Nil	NO	Y	Contractual
Dr.Shiv Ranjan Kumar	AWQPK5876J	Ph.D	MNIT	2016	1 Years 10 Months	Associate Professor	14-Sept- 16	16-Aug-16	ME	Production Engineering	10	Nil	NO	Y	Contractual
Prem Singh	CMNPS9364Q	M.Tech	SVNIT	2009	3 Years 11 Months	Assistant Professor		20-July-15	ME	Industrial Process Equipment Design	1	Nil	NO	Y	Contractual
Vikas Tiwari	AIJPT7150M	M.Tech	IIT, BHU	2014	4 Years 10 months	Assistant Professor		11-Aug-14	ME	Machine Design	0	Nil	NO	Y	Contractual

**Table B.5b**

# [SELF ASSESSMENT REPORT]



## Faculty Information (Session 2016- 17)

Name of the Faculty Member	Pan Card Number	Qualification			Association with the Institution	Designation	Date on which Designated as Professor/ Associate Professor	Date of Joining the Institution	Department	Specialization	Academic Research			(In case Currently Associated is ("No") Date of Leaving Currently Associated (Y/N)	Nature of Association (Regular/Contract)
		Degree (highest degree)	University	Year of attaining higher qualification							Research Paper Publications	Ph. D. Guidance	Faculty Receiving Ph.D. during the Assessment Years		
Manish Jain	AANPJ7357E	M.Tech	MNIT	2005	17 Years 2 Months	Assistant Professor		7-Aug-01	ME	Manufacturing Systems Engineering	5	Nil	NO	Y	Regular
Lalit Kumar Sharma	BQSPS3044K	M. Tech	MNIT	2013	11 Years 2 Months	Assistant Professor		13-Aug-07	ME	Manufacturing Systems Engineering	6	Nil	NO	Y	Regular
Rajendra Kumar Gupta	AGVPG7205J	M.Tech	Jagannath University	2014	11 Years 1 Months	Assistant Professor		17/Sep/07	ME	Manufacturing Systems Engineering	4	Nil	NO	Y	Regular
Kuldeep Sharma	BKOPS5002H	M.Tech	MJRP	2014	12 Years 2 Months	Assistant Professor		25-Aug-06	ME	Manufacturing Systems Engineering	5	Nil	NO	Y	Regular
Aashish Nagpal	AUYPN8399M	M.Tech	Jagannath University	2014	8 Years 2 Months	Assistant Professor		16-Aug-10	ME	Manufacturing Systems Engineering	3	Nil	NO	Y	Regular
Nikhil Jain	ARJPJ7522J	M.Tech	Jagannath University	2015	6 Years 8 Months	Assistant Professor		16-Feb-12	ME	Production Engineering	5	Nil	NO	Y	Regular



## [SELF ASSESSMENT REPORT]



Dayal Singh Rathore	ARZPR1164L	M.Tech	Jagannath University	2015	6 Years 3 Months	Assistant Professor		23-Jul-12	ME	Production Engineering	3	Nil	NO	Y	Regular
Hukam Chand Nagar	AXAPC7807L	M.Tech	Jagannath University	2017	6 Years 3 Months	Assistant Professor		23-Jul-12	ME	Thermal Engineering	2	Nil	NO	Y	Regular
Akhil Vijay	AHJPV3272D	M.Tech	Jagannath University	2016	6 Years 3 Months	Assistant Professor		24-Jul-12	ME	Production Engineering	4	Nil	NO	Y	Regular
Ravindra Singh Yadav	AJHPY2527J	M.Tech	Jagannath University	2017	6 Years 3 Months	Assistant Professor		24/Aug/12	ME	Manufacturing Systems Engineering	2	Nil	NO	10.02.2018	Regular
Pavan Gupta	BBBGP8184L	M. Tech.	IIT Delhi	2013	3 Years 11 Months	Assistant Professor		07/Jan/13	ME	Industrial Tribology and Maintenance Engineering	1	Nil	NO	25.12.2016	Regular
Abhishek Kumar	BVBPK2936A	M.Tech.	Jagannath University	2014	5 Years 2 Months	Assistant Professor		10-Aug-13	ME	Manufacturing Systems Engineering	4	Nil	NO	Y	Regular
Satyendra Kumar	BSKPK2741R	M.Tech.	RTU,Kota	2014	4 Years 3 Months	Assistant Professor		16-Jul-14	ME	Machine Design	7	Nil	NO	Y	Regular
Sandeep Yadav	ALYPY2147F	M.Tech.	NIT Jalandhar	2014	3 Years 2 Months	Assistant Professor		16-Jul-14	ME	Mechanical Engineering	2	Nil	NO	21.09.2017	Regular
Bharat Sharma	AYIPS3204L	M.Tech.	IIT Kanpur	2015	3 Years	Assistant Professor		18/Jul/14	ME	Industrial and Management Engineering	1	Nil	NO	13.07.2017	Regular
Vipin Goyal	AKFPG4807Q	M.Tech.	IIT Roorkee	2014	3 Years 9 Months	Assistant Professor		18/Jul/14	ME	Industrial Metallurgy	4	Nil	NO	31.03.2018	Regular
Dr. Manish Shrivastava	ARUPS7035A	M.Tech/Phd (MBA)	Jagannath University	2014	4 Years 3 Months	Assistant Professor		21-Jul-14	ME	Manufacturing Systems Engineering	4	Nil	NO	Y	Regular

## [SELF ASSESSMENT REPORT]



Rishi Kumar	BOHPK9921C	M.Tech.	NIT Jalandhar	2013	1 Year and 6 Months	Assistant Professor		02/Sep/15	ME	Industrial Engineering	1	Nil	NO	23/Feb/17	Regular
Veerendra Kumar	CKGPK4471D	M.Tech.	NIT Jalandhar	2014	3 Years 1 Months	Assistant Professor		3-Jul-15	ME	Mechanical Engineering	3	Nil	NO	Y	Regular
Dr. Bhuvnesh Bhardwaj	AONPB5285K	Ph.D.	SLITE	2016	3 Years 3 Months	Associate Professor	01/Oct/16	14-Jul-15	ME	Manufacturing Systems Engineering	12	Nil	Yes	Y	Regular
Md. InzamamUlHaque	AMQPH7828H	M.Tech.	RTU Kota	2017	2 Years 9 Months	Assistant Professor		29-Jul-15	ME	Thermal Engineering	3	Nil	NO	18.04.2018	Regular
Nikita Agarwal	BNTPA7722E	M.Tech.	RTU Kota	2017	2 Years 7 Months	Assistant Professor		08/Jan/15	ME	Machine Design	1	Nil	NO	24.07.2017	Regular
Tejendra Singh	ANEPT2083P	M.Tech	Jagannath University	2014	2 Years 9 Months	Assistant Professor		4-Jan-16	ME	Manufacturing Systems Engineering	2	Nil	NO	Y	Regular
Satyaprakash Saini	BJQPS8962K	M.Tech	MNIT	2015	2 Years 9 Months	Assistant Professor		20-Jan-16	ME	Metallurgical and material Engineering	3	Nil	NO	Y	Regular
AnanyaChattree	BFSPC5580H	M.Tech	IIT Roorkee	2015	2 Years 9 Months	Assistant Professor		04/Jan/16	ME	Production & Industrial Engineering	1	Nil	NO	Y	Regular
Gaurav Jain	BEUPJ6288J	M.Tech	MNIT	2016	2 Years 3 Months	Assistant Professor		21-Jul-16	ME	Industrial Engineering	2	Nil	NO	Y	Regular
Shashank Shekhar Singh	DKXPS5394K	M.Tech	AMU	2016	2 Years 3 Months	Assistant Professor		1-Jul-16	ME	Machine Design	3	Nil	NO	Y	Regular
Shrikant Bansal	AZWPB3081B	M.Tech	MNIT	2016	2 Years 2 Months	Assistant Professor		1-Aug-16	ME	Industrial Engineering	3	Nil	NO	Y	Regular

## [SELF ASSESSMENT REPORT]



Dr. M P Singh	AOPPS5028F	M.tech/Ph.D	MNIT /Jagannath University	2014	2 Years 2 Months	Professor		19-Aug-16	ME	Mechanical Engineering	11	Nil	NO	Y	Regular
Tejbahadur Singh	CMQPS7636J	M.Tech	NIT Jalandhar	2015	1 Years 9 Months	Assistant Professor		2-Jan-17	ME	Mechanical Engineering	3	Nil	NO	Y	Regular
Priti P. Bodkhe	ATVPB1700A	M.Tech	Pune University	2016	1 Years 9 Months	Assistant Professor		3-Jan-17	ME	Heat and Power Engineering	1	Nil	NO	Y	Regular
Palak Jindal	AMHPN6656J	M.Tech	Kurukshetra University	2014	1 Years 9 Months	Assistant Professor		4-Jan-17	ME	Production & Industrial Engineering	2	Nil	NO	Y	Regular
Hemant Bansal	APGPB2872J	M.Tech	RTU, Kota	2016	1 Years 9 Months	Assistant Professor		2-Jan-17	ME	Production Engineering	3	Nil	NO	Y	Regular
AkhileshPaliwal	CPSP3593N	M.Tech	NIT Jalandhar	2014	1 Years 9 Months	Assistant Professor		3-Jan-17	ME	Industrial and Management Engineering	3	Nil	NO	Y	Regular
Manmohan Siddh	BNPPS2864D	M.Tech	RTU, Kota	2012	1 Years 9 Months	Assistant Professor		2-Jan-17	ME	Manufacturing Systems Engineering	2	Nil	NO	Y	Regular
Yogesh Dubey	AVGPD6643R	M.Tech	Jagannath University	2014	1 Years 8 Months	Assistant Professor		8-Feb-17	ME	Manufacturing Systems Engineering	3	Nil	NO	Y	Regular
UtpalChakrabarty	AAHPC5325R	M.Tech	NIMS	2013	1 Years 08 Months	Professor		16-Feb-17	ME	Industrial Engineering	0	Nil	NO	Y	Regular
Dr.M.S. Sodhi	ACRPS7035C	Ph.D	IIT, Kanpur	1981	3 Years 4 Months	Professor	18-Feb-15	18-Feb-15	ME	Metallurgy Engineering	12	Nil	NO	Y	Contractual
Dr. Shiv Ranjan Kumar	AWQPK5876J	Ph.D	MNIT	2016	1 Years 10 Months	Associate Professor	14-Sept-16	16-Aug-16	ME	Production Engineering	10	Nil	NO	Y	Contractual

## [SELF ASSESSMENT REPORT]



Prem Singh	CMNPS9364Q	M.Tech	SVNIT	2009	2 Years 11 Months	Assistant Professor		20-July-15	ME	Industrial Process Equipment Design	1	Nil	NO	Y	Contractua l
Vikas Tiwari	AUPT7150M	M.Tech	IIT, BHU	2014	3 Years 10 months	Assistant Professor		11-Aug-14	ME	Machine Design	0	Nil	NO	Y	Contractua l

*Table B.5c*



5.1 Student Faculty Ratio [20]

Year	CAYm1 2016-17	CAY 2017-18	CAYp1 2018-19
u1.1	138	131	125
u1.2	151	138	131
u1.3	150	151	138
UG1	<b>439</b>	<b>420</b>	<b>394</b>
u2.1	56	57	50
u2.2	64	56	57
U2.3	62	64	56
UG2	<b>182</b>	<b>177</b>	<b>163</b>
Total No. of Students in the Department (S)	<b>621</b>	<b>597</b>	<b>557</b>
No. of Faculty in the Department (F)	<b>36.5</b>	<b>36.5</b>	<b>33</b>
Student Faculty Ratio (SFR)	<b>17.01</b>	<b>16.35</b>	<b>16.87</b>
Average SFR	<b>16.74</b>		
Marks	<b>18</b>		

Table B.5.1



**5.1.1. Provide the information about the regular and contractual faculty as per the format mentioned below:**

Year	Total number of regular faculty in the department	Total number of contractual faculty in the department
CAYp1	34	0
CAY	34	4
CAYm1	37	4

**Table 5.1.1**

**5.2 Faculty Cadre Proportion [25]**

Year	Professors		Associate Professors		Assistant Professors	
	Required F1	Available	Required F2	Available	Required F3	Available
CAYm1 2016-17	3.45	3	6.9	3	20.7	35
CAY 2017-18	3.31	3	6.63	3	19.9	32
CAYp1 2018-19	3.09	3	6.18	4	18.56	27
Average Numbers	3.28	3	6.57	3.33	19.72	31.33
Cadre Ratio Marks		<b>23.18</b>				

**Table B.5.2**

**Fig. 5.2: Faculty Cadre Proportion**

**5.3 Faculty Qualification [25]**

Years	X	Y	F	$FQ=2.5 \times [(10X + 4Y)/F]$
CAYp1 2018-19	5	28	27.85	14.54
CAY 2017-18	2	33	29.85	12.39
CAYm1 2016-17	2	35	31.05	12.88
Average Assessment				13.27



*Table B.5.3*

**5.4 Faculty Retention [25]**

**No of Faculties in CAYm2 (2015-16) = 29**

**No. of regular faculty members in CAYm1 2016-17= 38**

**Percentage Faculty retention = 86.20 %**

**CAY 2017-18 = 34**

**Percentage Faculty retention = 68.96 %**

**CAYp1 2018-19= 33**

**Percentage Faculty retention =55.71 %**

**Average Percentage = 70.02 %**

**Marks = 15**

<b>Item</b>	<b>Marks</b>
(% of faculty retained during the period of assessment keeping CAYm3 as base year)	
>=90% of required Faculty members retained during the period of assessment keeping CAYm3 as base year)	25
>=75% of required Faculty members retained during the period of assessment keeping CAYm3 as base year)	20
>=60% of required Faculty members retained during the period of assessment keeping CAYm3 as base year)	15
>=50% of required Faculty members retained during the period of assessment keeping CAYm3 as base year)	10
<50% of required Faculty members retained during the period of assessment keeping CAYm3 as base year)	0

*Table B.5.4*



**5.5 Innovations by the Faculty in Teaching and Learning [20]**

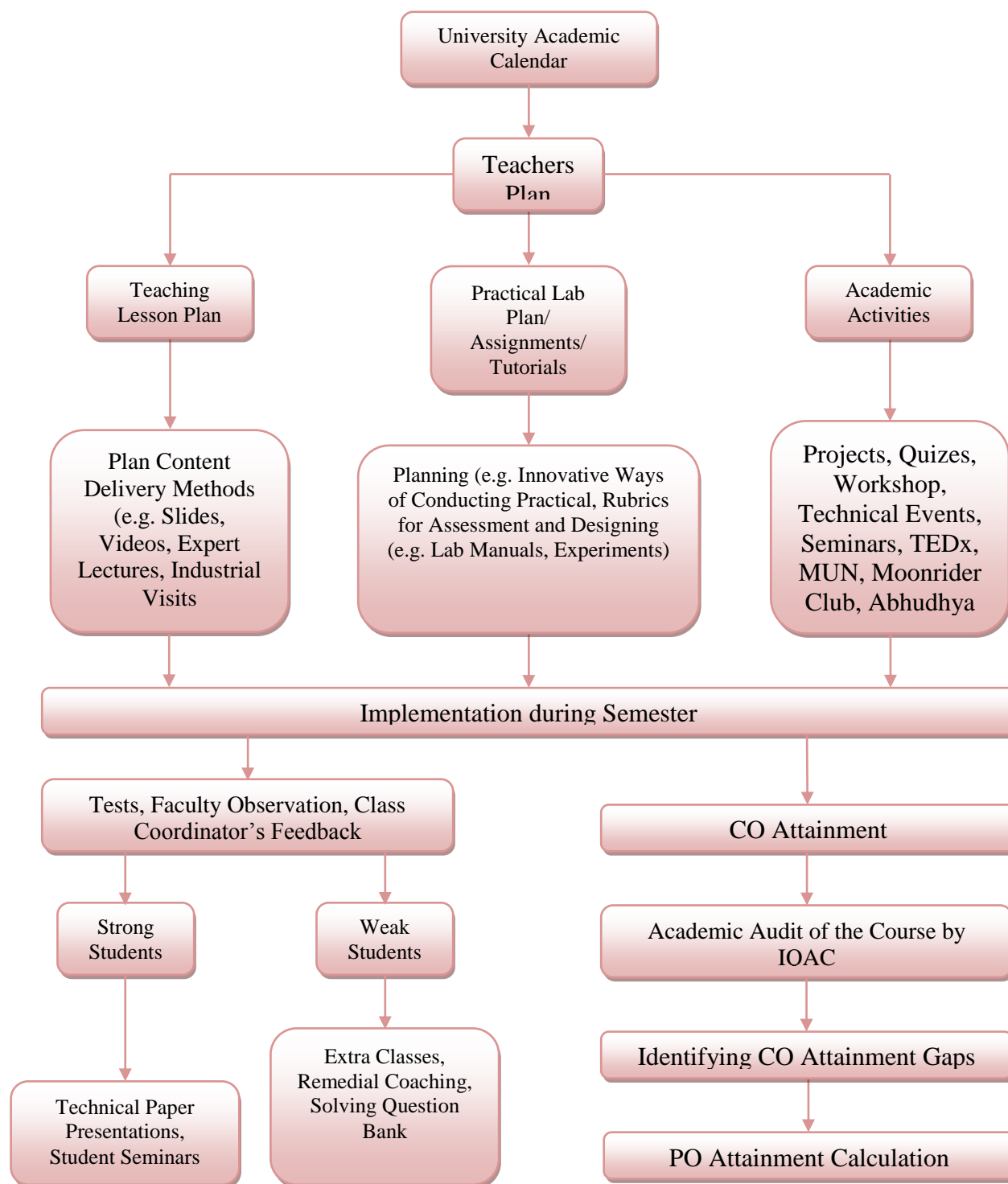





### Innovation by the faculty in teaching and learning

1. Various charts and models used for better understanding.
2. Demonstration using industrial standard simulation software.
3. Group assignments are provided in labs and in classes also to insure healthy competition, team work and new and improved outcomes of the problem.
4. Faculty members use to deliver lectures with the help of Videos and Animations in class room. As it is really meaningful way to present the teaching stuff in practical and demonstrated way so that the student can design an image of what is happening in his mind.
5. Research papers are used to teach student about new technologies and research gap that also help the students to gain knowledge of newer and advanced techniques as well to select project for the final terms.
6. Learn emerging Advances are used as beyond curricula as faculty introduce new experiments designed on the basis of theory syllabus and students skills in regular lab sessions.
7. NPTEL, SWAYAM,
8. Technical Quizzes
9. Provide students with the keywords of the related topic to make student grasp the procedure easily.
10. Fabrication/ Generation/Development of a demo model as industry to attain the conceptual phenomenon.
11. Laboratory Improvement future trends, under this the faculty member handling the lab session prepare a manual with different activities.
12. Innovation in assessments in this special assessment procedure is designed and implemented to collect the attainment levels of course outcomes and program outcomes on frequent basis.
13. Innovation in Evaluations in this we use process to enhance the understanding level and presentation skills.
14. Govt jobs cell (for preparation of govt. Job and for PSUs)

## [SELF ASSESSMENT REPORT]



### 5.6 Faculty as participants in Faculty development/training activities/STTPs [15]

#### Faculty as participants in FDP

Name of the faculty	Maximum 5 Per Faculty [2015-16]	Maximum 5 Per Faculty [2016-17]	Maximum 5 Per Faculty [2017-18]
Mr. Manish Jain	2	2	2
Mr. Lalit Kumar Sharma	2	3	2
Mr. Rajendra Kumar Gupta	2	2	2
Mr. Kuldeep Sharma	2	2	2
Mr. Aashish Nagpal	2	2	1
Mr. Nikhil Jain	2	2	1
Mr. Dayal Singh Rathore	2	2	2
Mr. Hukam Chand Nagar	2	2	1
Mr. Akhil Vijay	2	2	1
Mr. Ravindra Singh Yadav	2	2	1
Mr. Pavan Gupta	2	2	0
Mr. Abhishek Kumar	2	2	1
Ms. Jyoti Verma	2	2	0
Mr. Satyendra Kumar	2	2	3
Mr. Sandeep Yadav	2	2	0
Mr. Bharat Sharma	2	0	0
Mr. Vipin Goyal	2	3	1
Dr. Manish Shrivastava	2	2	2
Mr. Rishi Kumar	2	2	
Mr. Veerendra Kumar	2	2	1
Dr. Bhuvnesh Bhardwaj	2	3	2
Mr. Md. Inzamam Ul Haque	2	2	1
Ms. Nikita Agarwal	2	2	0
Mr. Tejendra Singh	1	2	2
Mr. Tejbahadur Singh	0	0	2
Mr. Yogesh Dubey	0	0	2
Ms. Palak Jindal	0	0	1
Mr. Gaurav Jain	0	1	1
Mr. Shrikant Bansal	0	1	1
Dr. M.P. Singh	0	2	2
Mr. Hemant Bansal	0	0	2

## [SELF ASSESSMENT REPORT]



Mr. Manmohan Siddh	0	0	1
Mr. Akhilesh Paliwal	0	0	1
Ms. Priti Bodkhe	0	0	0
Mr. Shashank Shekhar	0	2	2
Mr. Satyaprakash Saini	1	1	1
Mr. Ananya Chattree	1	2	1
<b>SUM</b>	49	58	45
<b>RF : Number of faculty</b>	32.35	31.05	29.85
<b>Assessment =</b>	9.1	11.15	9.0
<b>Average assessment over</b>	9.75		

*Table B.5.6*

### 5.7 Research and Development (30)

#### 5.7.1 Academic Research [10]

Details of Ph.D.

Name of Faculty Member	Ph.D awarded on	Institute	Title of thesis	Supervisor's Name
Dr. Bhuvnesh Bhardwaj	27/7/2016	Sant Longowal institute of engineering and technology, longowal, Punjab	Mathematical Modelling and Selection of Optimum Parameter for Minimum Surface Roughness in Metal Machining	<i>Dr. Rajesh Kumar Dr. P.K. Singh</i>

# [SELF ASSESSMENT REPORT]



## Number of research publications

S.No.	Name & Designation of the faculty member	2015-16, 2016-17, 2017-18, 2018-19			
		IJ	NJ	IC	NC
1	Mr. Manish Jain	2	0	2	1
2	Mr. Lalit Kumar Sharma	2	0	2	2
3	Mr. Rajendra Kumar Gupta	2	0	2	3
4	Mr. Kuldeep Sharma	2	0	2	2
5	Mr. Aashish Nagpal	2	0	2	2
6	Mr. Nikhil Jain	3	0	3	3
7	Mr. Dayal Singh Rathore	2	0	2	2
8	Mr. Hukam Chand Nagar	2	0	2	1
9	Mr. Akhil Vijay	2	0	2	3
10	Mr. Ravindra Singh Yadav	2	0	2	2
11	Mr. Pavan Gupta	1	0	1	1
12	Mr. Abhishek Kumar	2	1	2	2
13	Mr. Satyendra Kumar	2	0	4	5
14	Mr. Sandeep Yadav	1	0	1	2
15	Mr. Bharat Sharma	0	0	0	1
16	Mr. Vipin Goyal	1	0	1	2
17	Dr. Manish Shrivastava	2	0	2	3
18	Mr. Rishi Kumar	1	0	1	1
19	Mr. Veerendra Kumar	2	0	2	2
20	Dr. Bhuvnesh Bhardwaj	7	0	8	1
21	Mr. Md. Inzamam Ul Haque	2	0	2	2
22	Ms. Nikita Agarwal	1	0	1	1
23	Mr. Tejendra Singh	2	0	3	1

## [SELF ASSESSMENT REPORT]



24	Mr. Tejbahadur Singh	1	0	1	2
25	Mr. Yogesh Dubey	1	0	1	2
26	Ms. Palak Jindal	1	0	1	1
27	Mr. Gaurav Jain	2	0	2	1
28	Mr. Shrikant Bansal	2	0	2	2
29	Dr. M.P. Singh	8	0	5	0
30	Mr. Hemant Bansal	1	0	1	2
31	Mr. Manmohan Siddh	2	0	2	1
32	Mr. Akhilesh Paliwal	1	0	1	2
33	Ms. Priti Bodkhe	1	0	1	1
34	Mr. Shashank Shekhar Singh	2	0	3	1
35	Mr. Satyaprakash Saini	2	0	2	2
36	Mr. Ananya Chattree	2	0	2	1

### 5.7.2 Sponsored Research (05)

List of sponsored projects

S. No.	Project	Sponsored Agency	Amount
1	Rural Technologies Business Incubations	Department of Science and Technology	30 Lacs

### 5.7.3 Development Activities (10)

- Design and Fabrication of Go-kart
- Design and Fabrication of Efficycle
- Design and Fabrication of ATV
- Fabrication and Testing of Fibre Composites
- Design and Thermal Analysis of Piston Materials
- I.C. Engine Cut Sections
- Working Models
- Charts
- Assembling & Disassembling of Engines

## [SELF ASSESSMENT REPORT]



### 5.7.4 Consultancy (from Industry) (05)

Consultancy provided by the faculty members

S.No.	Name of faculty	Name of organization to which consultancy provided	Nature of work	Amount
1	Dr. M.P.Singh	RAYFUEL ENERCON Pvt. Ltd.	Winch test	5000/-
2	Mr. Kuldeep Sharma	M/s balaji associates	Die design	5000/-
3	Dr. Bhivnesh Bhardwaj	R tekhn solution	Manufacturing	25000/-
4	Mr. Satyendra Kumar	Bhagwati drug company	Chemical testing	Nil
5	Mrs. Palak Jindal	Jindal tech infrastructure pvt ltd.	Structure construction	Nil
6	Md. Inzamam Ul Haq	Unison machinery pvt ltd.	Production	Nil

### 5.8 Faculty Performance Appraisal and Development System (FPADS) [30]

Faculty member's performance appraisal is collected in two ways

- Students feedback
- Self appraisal of the faculty members

For faculty development in house FDP's are been conducted. Faculty members go to different institute and Organizations for the same.

**Jaipur Engineering College and Research Centre, Jaipur**

**FACULTY APPRAISAL FORM (Session 2016-2017)**

For best faculty award

Total 200 points

Name of Faculty Member:

Department:

Designation:

S. No.	Item Name	Maximum Points	Points obtained
1	Academic result 30 points average (90% students having more than 70% : 30 points, 80-89% students having more than 70% result: 27 points, 70-79% students having more than 70% result: 24 points, 60-69% students having more than 70% result: 21,60-69% students having more than 60% result: 18 points, 50-59% students having more than 60% result: 15 points else ZERO)	30	
2	Research Publication 20 points average (1 Sci indexed publication: 10 points, 1 publication having ISSN number : 5	20	

## [SELF ASSESSMENT REPORT]



	points, Else ZERO)		
3	Faculty development programme 10 point average (one faculty development programme minimum 5 days attended 5 points, 2 points for attending 2 days workshop, subject to maximum of 10)	10	
4	International / National conference 10 points average ( 5 points for attending International, 3 points for attending National of repute, 2 points for National conference)	10	
5	Research grant average 20 points for having grant of more than 5 lakh, if only project submitted to DST/other govt agency: 10 points, subject to maximum 20	20	
6	Patent 10 points	10	
7	Product development / startup 10 points	10	
8	Course material prepared for Govt job cell 15	15	
9	Innovation in teaching learning, video lecture, online MOOCs, Online notes uploading, any other 20 points	20	
10	Technical activity organized 5 points	5	
11	Participation in social responsibility 5 points / activity subject to maximum of 10	10	
12	Institute level activity organized 5 points, participation 2 points subject to maximum of 5	5	
13	Any award received, session chair in conference, guest lecture, invited talk, etc. 5 points	5	
14	HOD recommendation maximum 30 points (Departmental responsibility 2 points, NBA related activity 5)	30	
Total		200	

Note: HOD will verify the documentary proof.

Signature of Faculty

Signature of HOD



<b>CRITERION 6</b>	<b>FACILITIES AND TECHNICAL SUPPORT</b>	<b>80</b>
--------------------	---	-----------

**Vision of Jaipur Engineering College and Research Centre**

To become a renowned centre of outcome based learning, and work towards academic, professional, cultural and social enrichment of the lives of individuals and communities.

**Mission of Jaipur Engineering College and Research Centre**

- Focus on evaluation of learning outcomes and motivate students to inculcate research aptitude by project based learning.
- Identify, based on informed perception of Indian, regional and global needs, areas of focus and provide platform to gain knowledge and solutions.
- Offer opportunities for interaction between academia and industry.
- Develop human potential to its fullest extent so that intellectually capable and imaginatively gifted leaders can emerge in a range of professions.

**Vision of Department of Mechanical Engineering**

The Mechanical Engineering Department strives to be recognized globally for outcome based technical knowledge and to produce quality human resource, who can manage the advance technologies and contribute to society.

**Mission of Department of Mechanical Engineering**

- To impart quality technical knowledge to the learners to make them globally competitive mechanical engineers.
- To provide the learners ethical guidelines along with excellent academic environment for a long productive career.
- To promote industry-institute relationship.





## **Program Educational Objectives (PEOS)**

1. To provide students with the fundamentals of Engineering Sciences with more emphasis in Mechanical Engineering by way of analyzing and exploiting engineering challenges.
2. To train students with good scientific and engineering knowledge so as to comprehend, analyze, design, and create novel products and solutions for the real life problems in Mechanical Engineering.
3. To inculcate professional and ethical attitude, effective communication skills, teamwork skills, multidisciplinary approach, entrepreneurial thinking and an ability to relate Mechanical Engineering issues with social issues.
4. To provide students with an academic environment aware of excellence, leadership, written ethical codes and guidelines, and the self-motivated life-long learning needed for a successful professional career in Mechanical Engineering.
5. To prepare students to excel in Industry and Higher education by Educating Students along with High moral values and Knowledge in Mechanical Engineering.



## Programme Outcomes

### Program Outcomes

1. **Engineering knowledge:** Apply the knowledge of mathematics, science, engineering fundamentals, and an engineering specialization to the solution of complex engineering problems in Mechanical Engineering.
2. **Problem analysis:** Identify, formulate, research literature, and analyze complex Mechanical Engineering problems reaching substantiated conclusions using first principles of mathematics, natural sciences, and engineering sciences.
3. **Design/development of solutions:** Design solutions for complex Mechanical Engineering problems and design system components or processes that meet the specified needs with appropriate consideration for the public health and safety, and the cultural, societal, and environmental considerations.
4. **Conduct investigations of complex problems:** Use research-based knowledge and research methods including design of experiments, analysis and interpretation of data, and synthesis of the information to provide valid conclusions in Mechanical Engineering.
5. **Modern tool usage:** Create, select, and apply appropriate techniques, resources, and modern engineering and IT tools including prediction and modeling to complex Mechanical Engineering activities with an understanding of the limitations.
6. **The engineer and society:** Apply reasoning informed by the contextual knowledge to assess societal, health, safety, legal and cultural issues and the consequent responsibilities relevant to the professional Mechanical Engineering practice.
7. **Environment and sustainability:** Understand the impact of the professional Mechanical Engineering solutions in societal and environmental contexts, and demonstrate the knowledge of, and need for sustainable development.
8. **Ethics:** Apply ethical principles and commit to professional ethics and responsibilities and norms of the Mechanical Engineering practice.
9. **Individual and team work:** Function effectively as an individual, and as a member or leader in diverse teams, and in multidisciplinary settings in Mechanical Engineering.
10. **Communication:** Communicate effectively on complex Mechanical Engineering activities with the engineering community and with society at large, such as, being able to comprehend and write effective reports and design documentation, make effective presentations, and give and receive clear instructions.
11. **Project management and finance:** Demonstrate knowledge and understanding of the Mechanical Engineering and management principles and apply these to one's own work, as a member and leader in a team, to manage projects and in multidisciplinary environments.
12. **Life-long learning:** Recognize the need for, and have the preparation and ability to engage in independent and life-long learning in the broadest context of technological change in Mechanical Engineering.

# [SELF ASSESSMENT REPORT]



## 6.1 Adequate and well equipped laboratories, and technical manpower: (30)

Sr. No.	Name of the Laboratory	No. of students per setup (Batch Size)		Name of the Important Equipment	Weekly utilization status	Technical Manpower support		
		Batch Size	Students per setup			Name of the technical staff	Designation	Qualification
1	Computer Aided Engineering Graphics	30	1	Drawing table, Board and computer, Auto Cad	30 Hrs	Mr. Bir Singh	Senior Lab Tech	MCA
2	Workshop Practice 1	30	1	Lathe, Shaper, Electric Arc Welding Machines, Gas welding, Vices, soldering equipments, Drilling machine, milling machine.	30 Hrs	Mr. Rajendra Singh Naruka	Senior Lab Tech	ITI
						Mr. Hement Naiwal	Senior Lab Tech	Diploma
3	Workshop Practice 2	30	1	Foundry Equipments, Fitting tools, Furnace, carpentry tools casting equipments	30 Hrs	Mr. Sandeep Sharma	Lab Tech	Diploma
						Mr. Sunil Kumar Yadav	Lab Tech	ITI
4	Computer Aided Machine Drawing	30	1	Drawing table, Board and computer, Auto Cad	30 Hrs	Mr. Bir Singh	Senior Lab Tech	MCA
5	Material Science & Testing Lab	20	4	Universal Testing Machine, Impact testing Machine, Fatigue Testing Machine, Hardness Testing Machine, Polishing Machine, Microscope	12 Hrs	Mr. Hanuman Prasad Saini	Senior Lab Tech	ITI
6	Basic Mechanical Engineering Lab	20	4	Swing Machine, Air Conditioner, 2 Stroke Engine (luna), 4 Stroke Engine (Bike), 4 Stroke 3 Cylinder Engine	12 Hrs	Mr. Hanuman Prasad Saini	Senior Lab Tech	ITI

## [SELF ASSESSMENT REPORT]



7	Production Practice - I	20	4	Lathe Machine, Spot Welding, Furnace, Grinding Machine, Sieve, Sand testing Machine, Shaper Machine	18 Hrs	Mr. Rajendra Singh Naruka	Senior Lab Tech	ITI
8	Kinematics of Machine Lab	20	4	Models, Trifilar Suspension, Cam & follower Apparatus	12 Hrs	Mr. Narendra Singh	Senior Lab Tech	Diploma
9	Fluid Mechanics Lab	20	4	Bernoulli's Apparatus, Met centric Height Apparatus, Orifice Meter, Losses through pipe, flow through Notch, Pitot Tube	12 Hrs	Mr. Hanuman Prasad Saini	Senior Lab Tech	ITI
10	Thermal Engg Lab -I	20	4	Models & Cut sections of Various Engines, Valve timing Apparatus, Models of Boilers with mountings, Steering System, Models for flow of lubrication, Models of Cooling Systems, Models of Fuel System and Gear System.	12 Hrs	Mr. Sandeep Sharma	Lab Tech	Diploma
11	Heat Transfer Lab	20	4	Thermal Conductivity of Insulating powder, Thermal Conductivity of metal rod, Pin Fin Apparatus, Emissivity Apparatus, Drop Wise & Film Wise Condensation, Parallel & Counter Flow heat Exchanger, Stefan's Boltzmann apparatus	18 Hrs	Mr. Anil Prajapati	Lab Tech	Diploma
12	Dynamic of Machine Lab	20	4	Gyroscope, Governor, Journal bearing, Sliding mesh Automobile gear	12 Hrs	Mr. Narendra Singh	Senior Lab Tech	Diploma

## [SELF ASSESSMENT REPORT]



				box				
13	Production Practice - II	20	4	Various measuring tools, Bevel Protector, Slip Gauges, Sine bars, 3 wire gauge Monochromatic Check Light, Gear tooth vernier calliper	18 Hrs	Mr. Sunil Kumar Yadav	Lab Tech	ITI
14	Industrial Engineering Lab-I	20	4	Charts. Props related to probability, Stop watch	12 Hrs	Mr. Narendra Singh	Senior Lab Tech	Diploma
15	Vibration Lab	20	4	Simple pendulum, Compound pendulum, bifilar suspension, trifler spring mass system, single rotor & double rotor torsion system	12 Hrs	Mr. Anil Prajapati	Lab Tech	Diploma
16	Thermal Engg Lab -II	20	4	Refrigeration Unit, Heat Pump, Air Conditioner	18 Hrs	Mr. Anil Prajapati	Lab Tech	Diploma

**Table B.6.1**

## [SELF ASSESSMENT REPORT]



### Equipments/Tools as per stock registers

No.	Lab	Particular	Bill no.	Quantity	Date	Price (Rs)
1	Mechanical w/s (machine shop)	Lathe m/c 6' with 3 jaw chuck & motor with reversing switch	5913	1	29.03.2001	46000
2		Tool grinder (8")	5913	1	29.03.2001	3000
3		Oil-cane	10649	3	31.03.2002	157
4		Boring tool holder 3/8"	10650	1	31.03.2002	120
5		Parting tool holder 3/4"*2/8"	10650	1	31.03.2002	90
6		Knurling tool (single roller)	10650	1	31.03.2002	250
7		Tool post key 1/2"	10650	1	31.03.2002	125
8		Calliper 8" (outside)	376	1	07.03.2002	90
9		Calliper 8" (inside)	376	1	07.03.2002	90
10		Surface gauge 12"	9815	2	01.08.2002	300
11		Thread gauge (British & English)	9815	1	01.08.2002	50
12		Vernier calliper -200mm (outside)	383	1	07.08.2003	1400
13		Shaper tool holder 1/2"	384	1	07.08.2003	100
14		Lathe m/c 6' with chuck & motor with reversing switch	381	2	01.09.2003	84000
15		Shaper m/c 18" with motor	381	1	01.09.2003	42500
16		Milling m/c (zero no.) With motor	381	1	01.09.2003	27000
17		Power hacksaw 14" with motor	381	1	01.09.2003	9500
18		Four jaw centring chuck-10"	381	1	01.09.2003	5000
19		Dividing head (milling m/c)	460	1	20.02.2005	7500
20		Lathe m/c 9/2' with chuck & motor with reversing switch	460	2	20.02.2005	125000
21		Taper turning attachment	460	1	20.02.2005	16500

## [SELF ASSESSMENT REPORT]



22	Grinding attachment with motor	460	1	20.02.2005	7500
23	Vernier calliper - 300 mm	460	1	20.02.2005	8500
24	Combination set	460	1	20.02.2005	
25	Depth micrometer (0-25 mm)	460	1	20.02.2005	
26	Inside micrometer-100mm	460	1	20.02.2005	
27	Drill chuck -13mm	460	1	20.02.2005	
28	Machine vice-3" (milling m/c)	314	1	05.08.2005	
29	Lath drill sleeve set-3	314	1	26.12.2005	260
30	Capstan lathe m/c with motor	769	1	12.12.2006	84450
31	Boring tool holder	769	1	12.12.2006	2530
32	Component slide & cross slide	769	1	12.12.2006	3670
33	Collet	769	1	12.12.2006	910
34	Recessing slide for turret lathe	769	1	12.12.2006	3200
35	Self releasing holder	769	1	12.12.2006	3200
36	Knurling tool holder	769	1	12.12.2006	2800
37	Drilling & capstan tool set	769	1	12.12.2006	9500
38	Radial drilling m/c with motor	769	1	12.12.2006	28000
39	Lathe tool holder 3/8"	549	5	03.08.2007	675
40	Drill vice	3301	1	13.09.2008	1650
41	Lathe dog chuck barrier	2300	2	25.10.2010	1155
42	Slip gauge-83 piece	EME/28	1	06.08.2005	17000
43	Surface plate(CI) (600*600 mm <sup>2</sup> )	EME/28	1	26.08.2005	12500
44	Sine bar(i)-150 mm	EME/28	1	06.08.2005	2800
45	Sine bar(ii)-200 mm	EME/28	1	06.08.2005	4000
46	Sine bar (iii) - 300 mm	EME/28	1	06.08.2005	5400
47	Power press - 3 metric ton	769	1	12.12.2006	7700

## [SELF ASSESSMENT REPORT]



48		Hand press	769	1	12.12.2006	7500
49		Lathe machine with standard accessories fitted with Norton gear box Crompton motor 131 marked three jaw chuck standard accessories & fitted with electrical	TSS/2012 13/310	5	27.07.2012	517125
50		Vice (drill machine)	TSS/2012-13, 310	1	27.07.2012	1800
51		Tool holder bit 3/8	TSS/2012-13, 310	10	27.07.2012	2500
52		Tool holder 3/8	5768	5	30.08.2012	1300
53		Calliper outer 6"	5209	5	30.08.2012	192.5
54		Vernier 6"	5810	1	13.09.2012	650
55		Vernier 8"	5810	1	13.09.2012	750
56		Outside calliper 6"	7894	6	13.09.2013	240
57		Oil cane	90690	2	05.08.2015	160
58		Allen key 1/8"	90690	5	05.08.2015	30
59		Power hacksaw blade	113	10	12.08.2016	5144
60		Oil cane	116	2	16.08.2016	160
61		Allen key set	116	1	16.08.2016	163
62		Spanner set	116	1	16.08.2016	363
63	Mechanical workshop (welding shop)	Cylinder key	359	1	01.08.2000	250
64		A.C. step down transformer (250,300 amp)	1982	2	01.08.2000	7800
65		Chipping hammer	10651	3	01.08.2000	90
66		Tong	10650	2	01.08.2000	160
67		Oxygen regulator	359	1	01.08.2000	850
68		D.A. Regulator	359	1	01.08.2000	850
69		Gas welding torch	359	1	01.08.2000	425



## [SELF ASSESSMENT REPORT]



70	Gas welding cutter	359	1	01.08.2000	950
71	D.A. regulator	2276	1	22.04.2008	950
72	Gas welding torch	2276	1	22.04.2008	550
73	Air-cooled welding transformer 300 amp,2 phase	TSS/2012-13, 310	1	17.07.2012	11500
74	Welding holder	TSS/2012-13, 310	3	27.07.2012	900
75	Cable for welding transformer	TSS/2012-13, 310	10MTR	27.07.2012	1200
76	Oxygen gas regulator	TSS/2012-13, 310	1	27.07.2012	2750
77	Tong	5764	4	29.08.2012	800
78	Welding cable	2014-15/233	20FT	24.04.2014	800
79	Tong 12"	2014-15/233	1	24.04.2014	200
80	Chipping hammer	2014-15/233	10	24.04.2014	1300
81	Leather apron	2014-15/233	3	24.04.2014	750
82	TIG welding equipment -200 amps model cito-200	2014-15/183	1	01.07.2017	31500
83	Argon gas cylinder	2014-15/233	1	01.07.2017	13500
84	Spot welding equipment	2014-15/183	1	01.07.2017	31000
85	Welding goggles (black)	90689	1	05.08.2015	90
86	Welding goggles (simple black)	90689	2	05.08.2015	40
87	Welding goggles (white)	90689	2	05.08.2015	40
88	Hand screen (fibre)	90689	4	05.08.2015	360
89	Welding lead	113	10MTR	12.08.2016	2100
90	Welding cable (14x)	113	7	12.08.2016	175
91	Hand screen	113	3	12.08.2016	450

## [SELF ASSESSMENT REPORT]



92		Goggle	113	4	12.08.2016	80			
93		Oxygen regulator	116	1	16.08.2016	1380			
94	Mechanical w/s (foundry shop)	Tong (small)	86/EME	2	24.02.2001	23000			
95		Flat rammer		10					
96		Straight rammer		10					
97		Cross pin hammer		1					
98		Chisel		2					
99		Trowel pan shape		10					
100		Trowel straight		10					
101		Crucible no.10		3					
102		File 12"		2					
103		Clay washer		86/EME			1	17.01.2005	8000
104		Sleeve shaker (with accessories)		11/EME			1	17.01.2005	16500
105		Rapid moisture tester		11/EME			1	17.01.2005	3800
106		Tray 6'*4'*5'		TSS/2012-13, 310			45 KG	27.07.2012	5625
107	Moulding boxes 10"*10*4" (ms)	TSS/2012-13, 310	5	27.07.2012	12750				
108	Moulding board 115"*15" (wooden)	TSS/2012-13, 310	5	27.07.2012	13250				
109	Mechanical w/s (carpentry shop)	Carpentry vice 10"	9813	3	01.08.2000	3060			
110		T- clamp (5'/2")	9813	1	01.08.2000	540			
111		Carpentry saw	9815	9	01.08.2000	315			
112		Carpentry chisel	9815	17	01.08.2000	510			
113		Counter fit	9815	2	01.08.2000	300			

## [SELF ASSESSMENT REPORT]



114		Hand drill machine	9815	2	01.08.2000	1000
115		Triangular file 4"	901	1	17.07.2005	20
116		Screw driver	901	2	29.07.2005	75
117		Hand drill m/c 3/8"	901	1	05.08.2005	550
118		Carpentry vice-10"	163	4	06.08.2007	2600
119		Wood jack plane	163	2	06.08.2007	2600
120		Screw driver	163	1	06.08.2007	80
121		Measuring tap	163	1	06.08.2007	250
122		Wood ripping tool	163	1	06.08.2007	350
123		Try square	163	1	06.08.2007	600
124		Marking gauge	163	1	06.08.2007	450
125		Bits for drill	163	1	06.08.2007	750
126		Rasp's cut file (12")	9841	4	01.08.2000	420
127		Chisel 6" (flat)	5764	5	29.08.2012	450
128		Chisel 5/16 (square)	5209	5	30.08.2012	375
129		Carpentry saw 18"	5209	4	30.08.2012	320
130		Rasp cut file 12"	5209	5	30.08.2012	1650
131		Rasp cut file 12"	7894	5	13.09.2013	650
132		PVC hammer (30mm)	90989	5	05.08.2015	800
133		Rasp cut file 12"	116	5	16.08.2016	2835
134		Shaft hammer	113	5	12.08.2016	832
135	Mechanical w/s (fitting shop)	Vernier calliper	9814	1	01.08.2000	500
136		Outside calliper 6"		2		80
137		In side calliper 6"		2		80
138		Micro meter 25 mm		1		500
139		Try square 6"		7		350

## [SELF ASSESSMENT REPORT]



140	Try square 12"		4		480
141	Bevel square 6"		2		260
142	Sheet gauge (0.125-0.8mm)		1		220
143	Depth gauge 6"	9815	1		60
144	Vernier depth gauge 6"	9815	2		600
145	Vernier height gauge 300mm	9815	1		3900
146	Radius gauge (1-7 mm)		1		200
147	Thickness gauge (.05-.63mm)		1		750
148	Measuring scale 12"		10		450
149	Measuring tap	9814	1		50
150	Pipe vice 3"		1		200
151	C-clamp 6"		2		480
152	Bench vice		16		15200
153	Flat file 12"	9813	8		720
154	Flat file 12"	10649	6	31.08.2001	450
155	Smooth flat file 10"	10649	4	31.08.2001	1350
156	Smooth flat file 12"	10649	11	31.08.2001	
157	Needle file	9814	3	01.08.2000	900
158	Square file 12"	9814	4		420
159	Round file 12"	9813	4		420
160	Triangular file 6"	9814	6		180
161	Hammer ball peen (250 gms).	9815	6		720
162	Half round file	9813	4		520
163	Flat hammer (500gm)	9815	6		140
164	Cross peen hammer (250 gm)	9815	1		50
165	Soft hammer	9815	6		1740

## [SELF ASSESSMENT REPORT]



166	Claw hammers (125 gms.)	9815	2		60
167	Hacksaw frame 12"	9815	6		180
168	Tap & die set (1/8"-1/2")	9813	2		1000
169	Chisels (20mm)	9813	5		225
170	Hand rammer (11/16"-13/16")	9813	1		200
171	Pincer	9815	1		50
172	Angle protector	9814	1		200
173	Figure punch set	9814	1		100
174	Letter punch set	9814	1		300
175	Punch 90	9814	2		52
176	Drill chuck arbour	1982	1		240
177	Machine vice-3"	2156	1		550
178	Drill chuck (13mm)	1982	1	22.06.2000	1200
179	Electric hand drill machine 13mm	2156	1	22.06.2000	5632
180	Letter punch 1/8" set	2156	1	07.03.2003	70
181	Figure punch 1/8" set	2156	1	07.03.2003	210
182	Machine vice 3" drilling	314	1	14.10.2003	550
183	Bench drill (m/c) 13 mm	1982	1	26.06.2000	12147
184	Drill grinding	602	1	04.08.2007	650
185	Dividing leg calliper	602	2	04.05.2007	80
186	Carbide marker	602	2	04.08.2007	50
187	Hand hacksaw frame	549	5	03.08.2007	175
189	Hacksaw frame 300 mm	64251	2	08.09.2009	150
190	Tin cutter	4700	1	18.12.2000	100
191	Hand hacksaw frame	13	6	06.09.2010	240
192	Hacksaw frame	4766	4	10.08.2011	280

## [SELF ASSESSMENT REPORT]



193		Bench vice jaw size5" cast iron	2012-13/311	10	27.07.2012	32886	
194		Measuring tape shift	5764	1	29.08.2012	70	
195		Square file 12"	5768	5	30.08.2012	1380	
196		Figure set3/8"	5810	1	13.09.2012	320	
197		Scale 12"	5810	5	13.09.2012	450	
198		Try square 6"	5810	4	13.09.2012	600	
199		Steel rule 12"	7894	5	13.09.2013	40	
200		Steel rule 12"	90690	5	05.08.2015	100	
201		Triangular file 8"	90690	2	05.08.2015	180	
202		File handle	116	48	16.08.2016	960	
203		Bastard file 12"	116	4	16.08.2016	1024	
204		Mechanical w/s (smithy shop)	Hammer (double face)	163	1	06.08.2007	400
205			Anvil 20kg		2		4800
206	Centre hole punch and die.		1		400		
207	Rivets (set) (40 each)		4		160		
208	Chisel		2		1200		
209	Shear 12"		5764	4	29.08.2012	740	
210	Soldering iron (35w)		5207	3	30.08.2012	696	
211	Soldering iron (25w)		5207	2	30.08.2012	390	
212	Nylon hammer		7457	3	14.09.2012	300	
213	Soldering iron 25 w		2014-15/233	3	24.07.2014	450	
214	Rubber faced hammer		2014-15/233	5	24.07.2014	650	
215	Snip 10"		2014-15/233	5	24.07.2014	1700	
216	Bench vice 4"		875	4	26.09.2015	7880	
217	D-protractor		90690	2	05.08.2015	82	
218	Electric from		90690	2	05.08.2015	360	

## [SELF ASSESSMENT REPORT]



219		Sheet gauge	90689	1	05.08.2015	220
220	General tool's	Socket spanner set	377	1	07.03.2002	1800
221		Pipe wrench (12")	377	1	07.08.2003	300
222		Screw driver set 3 no	368	1	07.08.2003	105
223		Ring and fix spanner	549	5	03.08.2007	675
224		Pliers	368	1	01.08.2000	36
225		Screw driver 3"	9814	1	01.08.2000	80
226		Screw driver 12"	9814	1	01.08.2000	
227		Spanner (fix type)	9816	1	01.08.2000	150
228		Adjustable wrench 12 " (300mm)	1154	1	30.11.2006	250
229		Double ended spanner set	2014-15/183	1	01.07.2014	411
230		Screw driver 8"(200mm)	2014-15/183	1	01.07.2014	85
231		Screw driver 10"(250mm)	2014-15/183	1	01.07.2014	92
232		Screw driver 12" (300mm)	2014-15/183	1	01.07.2014	96
233		Materials testing	Impact testing m/c	23/04-05 TRD	1	15.06.2004
234	Fatigue testing m/c		23/04-05 TRD	1	15.06.2004	39100
235	Spring testing m/c		23/04-05 TRD	1	15.06.2004	30550
236	Rockwell hardness testing & brinell hardness		31/04-05 TRD	1	12.07.2004	29000
237	Torsion testing m/c		31/04-05 TRD	1	12.07.2004	85000
238	Universal testing m/c (40 tons)		39/04-05 TRD	1	25.07.2004	205600
239	Fluid mechanics	Apparatus for conducting orifice experiments	14	1	15.06.2004	21550
240		Notch apparatus to calibrate v-notch		1		22900
241		Pitot tube apparatus + pipe friction apparatus		1		27000
242		Bernoulli theorem		1		22900
243		Flow measurement by venturimeter, orifice meter		1		26000

# [SELF ASSESSMENT REPORT]



		and nozzle meter				
244		Metacentric height apparatus		1		7600
245		Pelton turbine model	23	1		4500
246		Kaplan turbine model	23	1		3000
247		Centrifugal pump test rig	70	1	03.02.2006	38200
248		Hydraulic ram test rig	70	1	03.02.2006	39100
249		Model of quick return mechanism		1		1380
						1480
250		Model of inversion of double slide chain		3		950
251		Model of various cam and flower		5		6600
		Various types of dynamometers				
		(i) Prony brake dynamometer				2500
252	Dynamics of machine/ kinematics of machine	(ii) Rope brake dynamometer		2		5800
253		Band brake	23		15.06.2004	2000
254		Single shoe				2000
255		Double shoe				2000
256		Band & block				2000
257		Disc				1540
258		Hydraulic				2900
259		Internal expanding				1900
260		Centrifugal clutch				1500
261		Claw clutch				1320
262		Cone clutch				1320



## [SELF ASSESSMENT REPORT]



263		Multi plate clutch				1940
264		Single plate clutch				1200
265		Inversion of four bar mechanism	31	1	12.07.2004	41450
266		Study of quick return mechanism	31	1		1930
267		Cam analysis apparatus	31	1		11650
268		Determine coefficient of friction	31	1		2700
269		Trifilar suspension	31	1		5800
270		Motorised gyroscope apparatus	50	1		14.09.2005
271		Governor apparatus	50	1	31900	
272		Journal bearing apparatus	50	1	63400	
273		Static & dynamic balancing apparatus	50	1	22900	
274		Moment of inertia of flywheel apparatus	50	1	3200	
275		Model of sliding mechanism gearbox	28	1	06.08.2005	5800
276		Material science	Specimen polishing machine	23/4-5 EME	1	15.06.2004
277	Carbon sulphur apparatus		23/4-5 EME	1	27400	
278	Metallurgical microscope		31/4-5 EME	1	17500	
279	Reference material (specimen)		31/4-5 EME	24	7000	
280	Vibration & noise egg	Whirling of shaft apparatus	70 EME	1	03.02.2006	28300
281		Vibration lab apparatus	358	1	09.04.2008	77952
282	Heat Transfer	Thermal conductivity of metal rod	EME/32	1	06.08.2005	22900
283		Thermal conductivity of insulating powder apparatus	EME/70	1	03.02.2006	27400
284		Stefan's Boltzmann's apparatus	EME/70	1	03.02.2006	21550
285		Pin fin test apparatus	EME/70	1	03.02.2006	26500
286		Natural convection apparatus	EME/70	1	05.02.2006	22900
287	Thermal engineering	Four stroke diesel engine	86	1	17.01.2005	1650
288		Four stroke petrol engine	86	1		1650

## [SELF ASSESSMENT REPORT]



289		Two stroke petrol engine	86	1		1650
290		Two stroke diesel engine	86	1		1500
291		Fuel supply system petrol engine	86	1		3800
292		Fuel supply system diesel engine	86	1		4200
293		Sp. Loaded safety valve	86	1		980
294		Feed check valve	86	1		1500
295		Model of single cylinder four stroke diesel engine	EME/8	1	06.08.2005	15700
296		Winkle engine	EME/50	1	14.09.2005	5100
297		Model of scooter carburettor	EME/08	1	14.09.2005	1000
298		IC engine	Model of pressure gauge	005/EME	1	11.04.2005
299	Two stroke single cylinder petrol engine test rig.		11/EME	1	11.04.2005	55000
300	Multi stage air compressor test rig.		11/EME	1	11.04.2005	76000
301	Four stroke four cylinder petrol engine testing with electrical dynamometer		44/EME	1	14.09.2005	166000
302	Exhaust gas calorimeter		32/EME	1	06.08.2005	19300
303	Four stroke 4 cylinder diesel engine test rig. with electrical dynamometer		32/EME	1	06.08.2005	175000
304	Thermal engineering-II	Vapour absorption system	216	1	07.12.2006	47200
305		Heat pump set-up	216	1		76000
306		Pyrometer	216	1		37000
307		A/c test rig 1.5 kg capacity	216	1		76000
308	Automobile engineering	Cooling system	86	1	17.01.2005	7000
309		Lubrication system	86	1	17.01.2005	5000
310		Model of ignition system	EME/28	1	06.08.2005	2900
311	Production engineering	Bore gauge 50-150	71921	1	21.08.2013	2625
312	engineering	Gear tooth Vernier	72093	1	06.09.2013	3150

## [SELF ASSESSMENT REPORT]



313		Dial test indicator 0.01mm accuracy on stand	2014-15/233	1	24.07.2014	2500
314		Telescopic gauge 8-150 mm	2014-15/233	1	24.07.2014	1100
315		Optical flat 25mm diameter	2014-15/233	1	24.07.2014	7500
316		High precision spirit level accuracy 0.02mm, size 150 mm	2014-15/233	1	24.07.2014	6500
317		Lathe tool dynamometer completes with mechanical sensing unit and digital force indicator to fit the following parameters. (i) Bed to chuck centre (ii) Check face plate (iii) Key bolt size M8.210m	2014-15/403	1	29.10.2014	53000

**LAB MANUAL**

**Lab** : PRODUCTION PRACTICE LAB-I

**Lab Code** : 3ME9A

**Branch** : MECHANICAL ENGINEERING

**Year** : 2<sup>nd</sup> YEAR 3<sup>rd</sup> SEMESTER



**JAIPUR ENGINEERING COLLEGE  
AND RESEARCH CENTRE**

Department of Mechanical Engineering

**Jaipur Engineering College and Research Centre, Jaipur**

(RTU, Kota)



**INDEX**

S.NO	CONTENTS	PAGE NO.
1	Vision and Mission	
2	Programme Educational Objectives (PEOs)	
3	Programme Outcomes (POs)	
4	Course Outcomes (COs)	
5	Mapping of COs with POs	
6	Syllabus	
7	Books	
8	Instructional methods	
9	Learning materials	
10	Assessment of outcomes	
11	Instructions sheet	
Exp:- 1	<b>Objective:</b> - Study of Lathe Machine, Lathe tolls and cutting speed and depth of cut.	
Exp:- 2	<b>Objective:</b> - To perform step turning, knurling and chamfering on lathe machine as per drawing.	
Exp:-3	<b>Objective:</b> - To perform taper turning (a) by tailstock offset method as per drawing (b) Using compound rest.	
Exp:-4	<b>Objective:</b> - To prepare the job by eccentric turning on lathe machine.	
Exp:-5	<b>Objective:</b> - To study shaper machine, its mechanism and calculate quick return ratio. To prepare a job on shaper from given mild steel rod	
Exp:-6	<b>Objective:</b> - To prepare mould of a given pattern requiring core and to cast it in aluminium	
Exp:-7	<b>Objective:</b> - To perform moisture test and clay content test.	
Exp:-8	<b>Objective:</b> - Strength Test (compressive, Tensile, Shear Transverse etc. in green and dry conditions) and Hardness Test (Mould and Core).	
Exp:-9	<b>Objective:</b> - To perform permeability test	
Exp:-10	<b>Objective:</b> - A.F.S. Sieve analysis test.	
Exp:-11	<b>Objective:</b> - Hands-on practice on spot welding	
Exp:-12	<b>Objective:</b> - Hands-on practice on Submerged arc welding	
Exp:-13	<b>Objective:</b> - Hands-on practice on metal inert gas welding (MIG) and tungsten inert gas welding (TIG).	
Exp:-14 (BC)	<b>Objective:</b> - To prepare a butt joint with mild steel strips using brazing technique.	



## 1. VISION and MISSION

### VISION:

- The Mechanical Engineering Department strives to be recognized globally for outcome based technical knowledge and to produce quality human resource, who can manage the advance technologies and contribute to society.

### MISSION:

1. To impart quality technical knowledge to the learners to make them globally competitive mechanical engineers.
2. To provide the learners ethical guidelines along with excellent academic environment for a long productive career.
3. To promote industry-institute relationship.

## 2. PROGRAMME EDUCATIONAL OBJECTIVES

1. To provide students with the fundamentals of Engineering Sciences with more emphasis in Mechanical Engineering by way of analyzing and exploiting engineering challenges.
2. To train students with good scientific and engineering knowledge so as to comprehend, analyze, design, and create novel products and solutions for the real life problems in Mechanical Engineering.
3. To inculcate professional and ethical attitude, effective communication skills, teamwork skills, multidisciplinary approach, entrepreneurial thinking and an ability to relate Mechanical Engineering issues with social issues.
4. To provide students with an academic environment aware of excellence, leadership, written ethical codes and guidelines, and the self-motivated life-long learning needed for a successful professional career in Mechanical Engineering.
5. To prepare students to excel in Industry and Higher education by Educating Students along with High moral values and Knowledge in Mechanical Engineering.



### 3. PROGRAM OUTCOMES

1. **Engineering knowledge:** Apply the knowledge of mathematics, science, engineering fundamentals, and an engineering specialization to the solution of complex engineering problems in Mechanical Engineering.
2. **Problem analysis:** Identify, formulate, research literature, and analyze complex Mechanical Engineering problems reaching substantiated conclusions using first principles of mathematics, natural sciences, and engineering sciences.
3. **Design/development of solutions:** Design solutions for complex Mechanical Engineering problems and design system components or processes that meet the specified needs with appropriate consideration for the public health and safety, and the cultural, societal, and environmental considerations.
4. **Conduct investigations of complex problems:** Use research-based knowledge and research methods including design of experiments, analysis and interpretation of data, and synthesis of the information to provide valid conclusions in Mechanical Engineering.
5. **Modern tool usage:** Create, select, and apply appropriate techniques, resources, and modern engineering and IT tools including prediction and modeling to complex Mechanical Engineering activities with an understanding of the limitations.
6. **The engineer and society:** Apply reasoning informed by the contextual knowledge to assess societal, health, safety, legal and cultural issues and the consequent responsibilities relevant to the professional Mechanical Engineering practice.
7. **Environment and sustainability:** Understand the impact of the professional Mechanical Engineering solutions in societal and environmental contexts, and demonstrate the knowledge of, and need for sustainable development.
8. **Ethics:** Apply ethical principles and commit to professional ethics and responsibilities and norms of the Mechanical Engineering practice.
9. **Individual and team work:** Function effectively as an individual, and as a member or leader in diverse teams, and in multidisciplinary settings in Mechanical Engineering.
10. **Communication:** Communicate effectively on complex Mechanical Engineering activities with the engineering community and with society at large, such as, being able to comprehend and write effective reports and design documentation, make effective presentations, and give and receive clear instructions.
11. **Project management and finance:** Demonstrate knowledge and understanding of the Mechanical Engineering and management principles and apply these to one's own work, as a member and leader in a team, to manage projects and in multidisciplinary environments.
12. **Life-long learning:** Recognize the need for, and have the preparation and ability to engage in independent and life-long learning in the broadest context of technological change in Mechanical Engineering.



## PSO-Program Specific outcomes

**PSO1.** Apply the knowledge of material science, manufacturing and design to implement the various concepts of vehicle mechanics.

**PSO2.** Apply the knowledge of 3D printing technology in design and development of prototypes.

## 4. COURSE OUTCOMES

### PRODUCTION PRACTICE LAB I [3ME9A]

Class: III semester II year

Branch: Mechanical Engineering

Schedule per Week Practical Hrs.: 3 Hrs

Examination Time = 3 Hrs

Maximum Marks = [Sessional/Mid-term (45) & End-term (30 )]

On successful completion of this course the students will be able to:

1. To **prepare** jobs on different machine like lathe, drilling shaper.
2. To **choose** the various tools for different operations.

### Mapping of COs with POs

COURSE OUTCOMES	PROGRAMME OUTCOMES											
	PO1	PO 2	PO 3	PO 4	PO 5	PO 6	PO 7	PO 8	PO 9	PO 10	PO 11	PO 12
I	H		H				H					
II	H	H	H		M							





5. SYLLABUS

PRODUCTION PRACTICE LAB I [3ME7A]

<b>Class: Sem. B. Tech.</b>		<b>Evaluation</b>
<b>Branch: ME</b> <b>Schedule per week</b> <b>Practical Hrs: (3)</b>		<b>Examination Time= 3 Hours</b> <b>Maximum Marks =</b> <b>Sessional/Mid-term(45) &amp; End-term(30)</b>
<b>S.No.</b>	<b>NAME OF EXPERIMENT</b>	
1	Study of Lathe Machine, Lathe tools and cutting speed and depth of cut.	
2	To perform step turning, knurling and chamfering on lathe machine as per drawing.	
3	To perform taper turning (a) by tailstock offset method as per drawing (b) Using compound rest.	
4	To prepare the job by eccentric turning on lathe machine.	
5	To study shaper machine, its mechanism and calculate quick return ratio. To prepare a job on shaper from given mild steel rod	
6	To prepare mould of a given pattern requiring core and to cast it in aluminium	
7	To perform moisture test and clay content test.	
8	Strength Test (compressive, Tensile, Shear Transverse etc. in green and dry conditions) and Hardness Test (Mould and Core).	
9	To perform permeability test	
10	A.F.S. Sieve analysis test.	
11	Hands-on practice on spot welding	
12	Hands-on practice on Submerged arc welding	
13	Hands-on practice on metal inert gas welding (MIG) and tungsten inert gas welding (TIG).	
14 (BC)	To prepare a butt joint with mild steel strips using brazing technique.	

6. BOOKS

1. Manufacturing process by R. K. Rajput

7. REFERENCE BOOKS:-

- Production Technology by P. C. Sharma, S, Chand publication
- Production Technology by O.P. Kahanna, Dhanpat Rai publication
- Workshop Technology by Hazara Choudhary



## **8. INSTRUCTIONAL METHODS**

### **8.1. Direct Instructions:**

- I. Black board presentation.
- II. Power point presentation.

### **8.2. Interactive Instruction:**

- I. Practical on respective equipment.
- II. Practical Examples.

## **9. LEARNING MATERIALS**

9.1. Lab Manual

9.2. Reference Books

## **10. ASSESSMENT OF OUTCOMES**

10.1. End term Practical exam

10.2. Quiz

10.3. Daily Lab interaction.



## 11. INSTRUCTIONS SHEET

**We need your full support and cooperation for smooth functioning of the lab.**

### **DO's**

1. Please switch off the Mobile/Cell phone before entering Lab.
2. Enter the Lab with complete data.
3. Check whether all equipments are available at your desk before proceeding for experiment
4. Intimate the lab In charge whenever you are incompatible in using apparatus
5. Arrange all the equipments and seats before leaving the lab.
6. Keep the bags in the racks.
7. Enter the lab on time and leave at proper time.
8. Maintain the decorum of the lab.
9. Utilize lab hours in the corresponding experiment.
10. Get your file checked by lab in charge before using it in the lab.

### **DON'TS**

1. Don't mishandle the apparatus.
2. Don't bring any external material in the lab.
3. Don't make noise in the lab.
4. Don't bring the mobile in the lab. If extremely necessary then keep ringers off.
5. Don't enter in the lab without permission of lab incharge.
6. Don't litter in the lab.

### **BEFORE ENTERING IN THE LAB**

1. All the students are supposed to prepare the theory regarding the next experiment
2. Students are supposed to bring the practical file and the lab copy.
3. Previous practical should be written in the practical file.
4. Any student not following these instructions will be denied entry in the lab.

### **WHILE WORKING IN THE LAB**

1. Adhere to experimental schedule as instructed by the lab incharge.
2. Get the previous experiment signed by the instructor.

## [SELF ASSESSMENT REPORT]

---



3. Take responsibility of valuable accessories.
4. Concentrate on the assigned practical and do not play games.
5. If anyone caught red handed carrying any equipment of the lab, then he will have to face serious consequences.

# [SELF ASSESSMENT REPORT]



JECRC, JAIPUR

## INDIVIDUAL TECHNICIAN DATA SHEET

Name of the Technical Member : Rajendra Singh Naruka

Designation : Senior Lab Instructor

Email Id: narukaraj@gmail.com

Contact Details : 9799060610



### I. Particulars of Educational Qualification: (only completed)

Category	Name of the Degree	Specialization	Year of Passing	Name of the College	Name of the University
ITI	ITI	Fitter	1989	Govt ITI, Bhundi	BTER

II. Academic Experience : 15 Years

III. Industrial Experience : 14 Years

### Sample Experiment

**Object:** - Study of Lathe Machine, Lathe tools and cutting speed and depth of cut.

#### Introduction:-

Machining is the process of converting the given work piece into the required shape and size with the help of machine tool. The most widely used machine tools is lathe. In simple words machining is the process of removing certain material from the work-piece.

**Lathe:-** Lathe is the machine tool which is used to perform several operations on the work piece. Lathe is useful in making several parts which are further assembled to make new machines. Hence lathe is known as “mother of machines”.

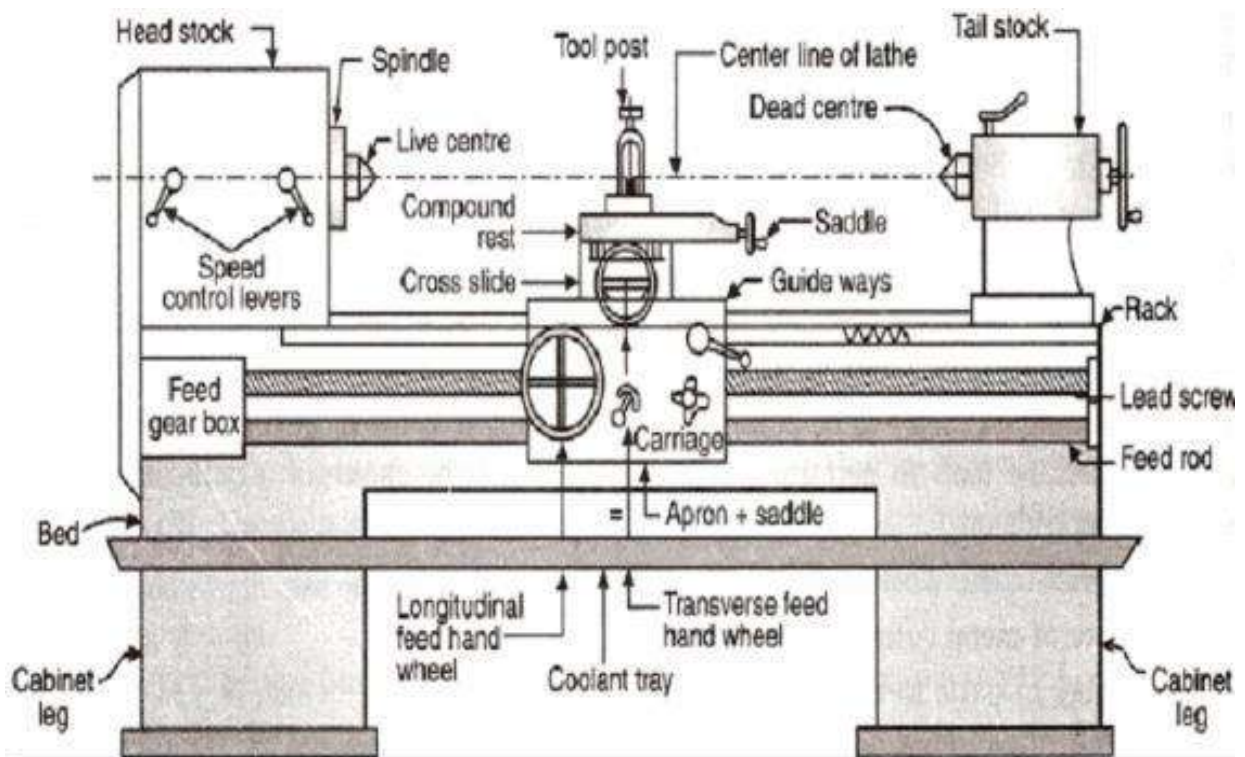

**Fig 1: Center Lathe**

#### Basic working principle of lathe machine

The lathe is a machine tool which holds the work piece between two rigid & strong supports called centres or in a chuck or in a face plate which revolves. The cutting tool is held and fed against

the revolving work. Cutting tool feed either parallel or at right angles to the axis of work-piece or may also at an angle.

## Types of Lathe Machine

Classification of Lathe Machine

1. Speed Lathe

2. Engine or Centre Lathe

(i) Light Work    (ii) Medium and heavy duty Lathe

3. Production type lathe

(i) semi automatic    (a) Capstan    (b) Turret

(ii) special purpose    (a) Duplicating    (b) Gap bed    (c) Wheel

## Parts of Lathe Machine

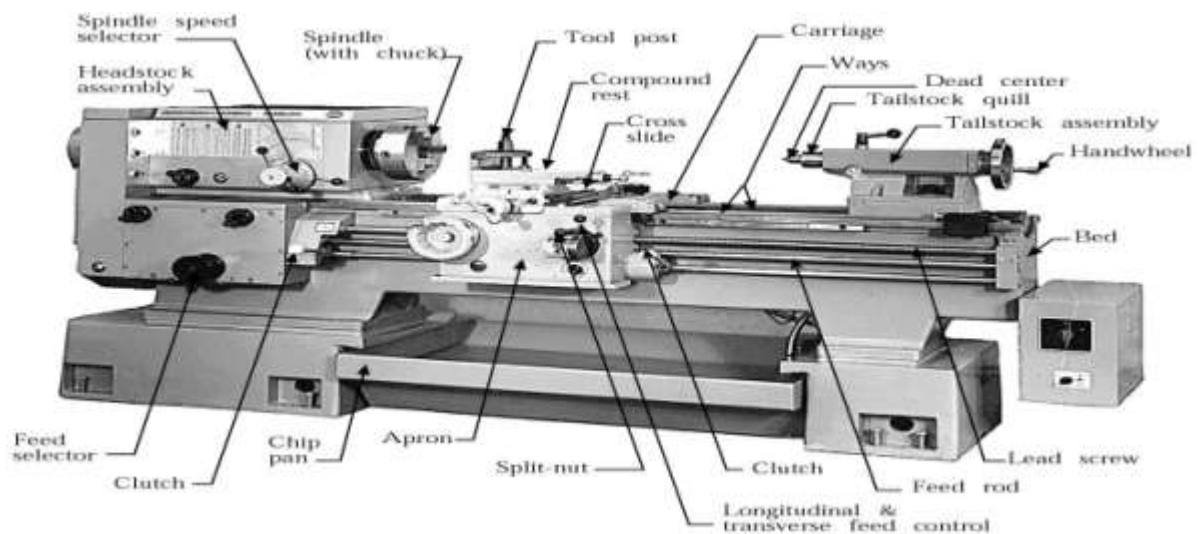

**Fig 2: Parts of Lathe Machine**

- 1. Bed :-** It is the foundation of lathe .On the top of bed there are two sets of guide ways – outer ways is for the carriage and inner ways for the tailstock .The bed is made of CI to absorb the shocks and vibration , during machining

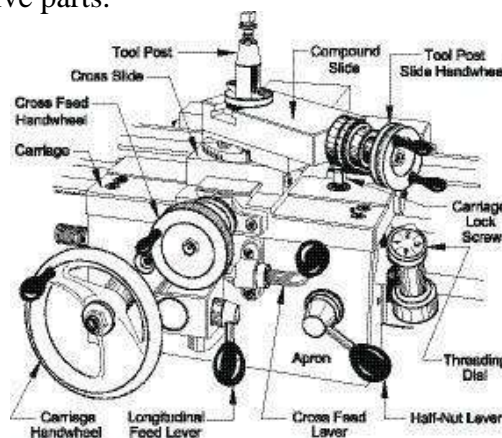

**Fig 3: Bed**

2. **Head stock:-**The headstock spindle, a hollow cylindrical shaft supported by bearings, provides a drive from the motor to the work holding device. A live centre and sleeve, a face plate, or a chuck can be fitted to the spindle nose to hold and drive the work.

### 3. Carriage:

The carriage controls and supports the cutting tool. By the help of this tool moves away or towards the headstock. It has five parts.



**Fig 4: Carriage**

- (i) **Saddle:** - On the top it supports the cross slide. It is H shaped casting mounted on the top of the lathe ways so it slides the way between the headstock and tailstock.
- (ii) **Cross slide:** - It is mounted on the saddle. The cross slide dovetail provides the cross movement (towards or away the operator) to the cutting tool. It supports the compound rest.



(iii) **Compound rest:** It is mounted on the top of the cross slide and is used to support the cutting tool. It can be swivelled to any angle for taper turning operations.

(iv) **Tool post:** - It is mounted above the compound rest. A T – slot is machined in the compound rest to accommodate the tool post. It clamps the cutting tool or cutting tool holder in a desired position.

(v) **Apron:** - It is fastened to the saddle and contains the feeding mechanism. The automatic feed lever is used to engage power feeds to the carriage and the cross slide

4. **Feed Rod and Lead Screw :**Feed rod is powered by a set of gears from the headstock

5. **Tailstock:** It is located at the right end of the lathe bed and it can be positioned anywhere in the bed. It is used for supporting lengthy jobs and also carries tool to carry out operations such as tapping, drilling, reaming.

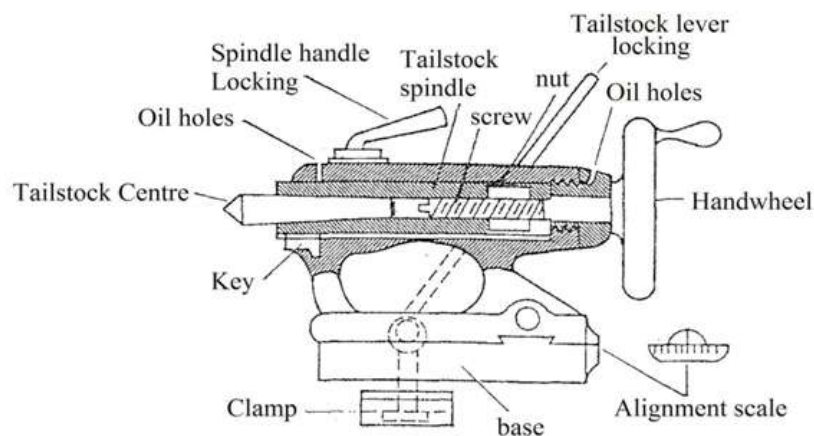

**Fig 5: Tail stock**

## WORK HOLDING DEVICES

1. **Lathe centers:** - They are used to support work. It has two categories of centers. Live center is one which is fitted in the headstock spindle. Dead is another one which is fitted in the tail stock.

2. **Chuck:** - It is a device used to hold a job. It is easily fitted on the thread cut on the end of



Head stock spindle. Various types of chuck are

(a) Two jaw chuck b) three jaw chuck c) four jaw chuck d) collet chuck e) Magnetic chuck

**3. Centers:** These are used to support work. Types of centers are:

Live centre

Dead centre

Tipped centre

Ball centre

**4. Rests:** - Rests are used to prevent bending of a slender job (having its length more than 12 times the diameter of the job approximately) due to its own weight and the vibrations during operations.

There are two types of rests

1. Steady rest or fixed steady

2. Follower rest of steady

**5. Mandrels :**

Plain mandrel

Stepped mandrel

Collared mandrel

Screwed mandrel

**6. Tail stock:** - It is located at the right end of the lathe bed and it can be positioned anywhere in the bed. It is used for supporting lengthily jobs and also carries tool to carry out operations such as tapping, drilling reaming.

**Lathe Operations:-**

1. **Facing:** - To produce a flat surface at the end of the part or for making face grooves.

2. **Turning:** produce straight, conical, curved, or grooved work pieces

3. **Taper Turning :-** It is different form of turning operation

4. **Chamfering:-** Cutting edge cuts an angle on the corner of the cylinder, forming a "chamfer

**5. Drilling and Reaming Operation:-**

Drilling is an operation through which holes are produced in a solid metal by means of a revolving tool called drill.

A drill is a rotary end cutting tool with more cutting lips and usually more flutes for the passage of chips and the admission of cutting fluid.

It is formed by the machine tool which is called drilling machine.

6. **Knurling:** - It is process of making serration on the work piece with the help of knurling tool. Work piece is rotated at lower speed amount of feed is given.

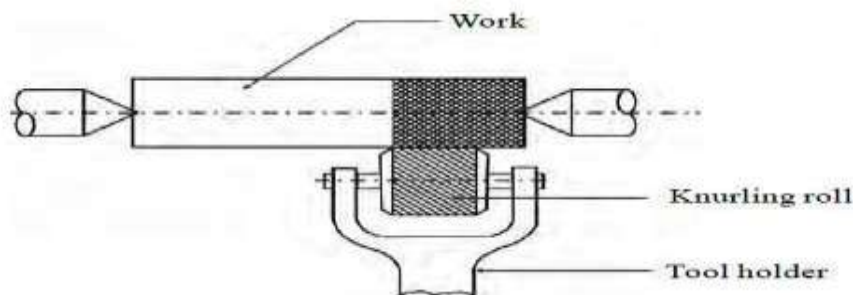

**Fig 6: Knurling Process**

**Cutting speed:-**

It is the peripheral speed of the work piece to the cutting tool

It is speed at which metal is removed by the tool from the work piece.

It is expressed in meter/min.

$$\text{Cutting speed } V = \pi DN / 1000$$

Where D= diameter of w/p in mm

N= r.p.m.



### **Feed:-**

It is defined as the rate of tool travel across a surface cutting it.

It is the distance of the tool advances for each revolution of the work piece.

It is expressed in mm/rev.

### **Depth of cut:-**

It is the perpendicular distance measured from the machined surface to the uncut surface of work. It is expressed in mm.

$$\text{Depth of cut } t = (D-d)/2,$$

Where: D=diameter of w/p before machining

d=diameter of w/p after machining

### **Expected Outcome:-**

### **Comments by Student:-**

## [SELF ASSESSMENT REPORT]



### 6.2 Additional facilities created for improving the quality of learning experience in laboratories: (25)

S. No.	Facility name	Details	Reason(s) for creating facility	Utilization	Areas in which students are expected to have enhanced learning	Relevance to POs/PSOs
1	Moon rider club	Fabrication	Lab is dedicated for students to fabricate various vehicles	As needed	Automobile and its components	PO1/ PO3/ PO9
2	Centre of excellence	Mechanical design software	Additional support for students	40 hours per month	Identify the problem and to attend the problem solving skills using design software	PO1/ PO2/ PO12
3	Heat pump, Vapor absorption, Spring testing machine, Window AC,	Machines and models	Additional knowledge for students	As needed	Various mechanical field	PO1
4	Internet facility	150 Mbps	Self learning/ seminars/ presentations/ solve assignments			
5	Smart class room	Fully equipped class room with projector	To demonstrate	As needed	Presentation/ seminars	PO5
6	Seminar hall	Mike setup and projector facility	For conducting workshops/ seminars/ conferences/ dept level extra-curricular activities	As needed	Exposure to current technologies	
7	Department library	Text books and references books	Additional support for students	As needed	Curriculum specified subjects	
8	Aerodynamic modelling	Fabrication	Students will be able to learn basic aerodynamic modelling and recent advancement in the field	As needed	Aerodynamics	PO1/PO2/ PO3/PO9/ PO12
9	Video's from NPTEL, etc.	Displayed in the smart class room	In-depth knowledge of respective subjects	As needed	Various mechanical subjects	

## [SELF ASSESSMENT REPORT]



10	e-books facility	e-learning materials, journal and magazines	To know about recent trends in science and technology and update the subject knowledge using various books and journals	As needed	Engineering and technology, automotive, advanced manufacturing etc.	
----	------------------	---	---	-----------	---	--

**Table B.6.2**

### Mapping of additional facilities with PO'S

PO Facility	PO1	PO2	PO3	PO4	PO5	PO6	PO7	PO8	PO9	PO10	PO11	PO12
Moon rider club	H	H	H	H	-	-			H	M	M	M
Centre of excellence	H	H	H	H	H				M			M
Heat pump, Vapour absorption, Window AC	H	M					M		M			
Spring testing machine	H	M					M		M			
Internet facility	M									M		
Smart class room										M		
Seminar hall										M		
Department library	M									M		
Aerodynamic modelling	H	M							M	M		
Video's from NPTEL, etc.	H									M		
e-books facility	H	M			M					M		



MOONRIDER CLUB



CENTRE OF EXCELLENCE



SPRING TESTING MACHINE





HEAT PUMP TEST RIG



AIR CONDITION TEST RIG

# [SELF ASSESSMENT REPORT]



**Report on CADD centre training:**

**Course Name: CADD Software Training**

**Faculty Coordinator:**

S.No.	Name	Department	Contact	Email
1	Satyendra Kumar	ME	8955480411	<a href="mailto:satyendrakumar.me@jecrc.ac.in">satyendrakumar.me@jecrc.ac.in</a>
2	Ravi Yadav	ME	9782891969	<a href="mailto:raviyadav.me@jecrc.ac.in">raviyadav.me@jecrc.ac.in</a>

## **1. Duration of Training**

### **Slot-1 AUTO CAD & ANSYS**

#### **Training Duration**

**Auto CAD- 40 Hours**

**ANSYS- 50 Hours**

Date- 31<sup>th</sup> Jan.2018 to 22<sup>th</sup> Feb.2018

Batch 1-1:30 pm to 3:30 pm

Batch 2- 3:30 pm to 5:30 pm

Venue- Cad Lab (DF-08 and DS- 11 -D Block)

### **Slot-2 SOLIDWORS**

#### **Training Duration (50 Hours)**

Date- 8<sup>th</sup> March.2018 to 25<sup>th</sup> April.2018 (approximated)

Time- 1:30 pm to 3:30 pm

Venue- Basement (DF-08-D- Block)

## [SELF ASSESSMENT REPORT]



### 2. No. of Students Attending Training:

#### Slot-1 Training Total Registration:

##### Auto CAD

S. No.	Branch	6 <sup>th</sup> Sem.	4 <sup>th</sup> Sem.	Total
1	ME	5	27	32

##### ANSYS

S. No.	Branch	6 <sup>th</sup> Sem.	4 <sup>th</sup> Sem.	Total
1	ME	3	22	25

#### Slot-2 Training Total Registration:

S. No.	Branch	6 <sup>th</sup> Sem.	4 <sup>th</sup> Sem.	Total
1	ME	5	33	38

### 6.3 Laboratories: Maintenance and overall ambiance: (10)

#### Infrastructure and Facility of the Mechanical Department:

S. No.	Infrastructure and Facility	Maintenance Description
1	Laboratories	Regular maintenance of machine is done. Budget is prepared based on academic requirement.
2	Equipment	Regular maintenance and records of equipments is maintained.
3	Computers	Lab instructor of computer laboratory is responsible for maintenance of systems and software.
4	Department Library	A faculty member is assigned as in-charge of department library. Students and faculty members of department will make use of the books available.
5	Internet /Intranet	Internet related matters are maintained by instructor.
6	Electricity	Electrical maintenance will be carried by electrical maintenance incharge.



**Maintenance Description**

**Ambience of the Mechanical Department**

1	Department has aquired number of laboratories as per academic requirement
2	Faculty members are provided with cabins with all the necessary facilities
3	The lab premises and the experimental setup/equipments are kept in good working conditions
4	Display of CO's, PO's, PEO's and display charts of the laboratories is maintained
5	Preventive maintain of the equipments carried out on regular basis. In case of major failure / repair, the service is carried out from external service providers
6	Drinking water facility to the students is provided
7	Cleanliness is maintained in the department by disposing all the waste material on a daily basis with the help of sufficient man-power
8	The labs are provided with power backup facilities wherever necessary and student baggage counters.
9	First Aid facility is maintained and monitored regularly.
10	Labs are provided with entry and exit gates separately to reduce conjunction and maintained decorum.

**Ambience in department**

**6.4 Project laboratory: (5)**

**Facilities for Project Lab**

1	Special lab with systems is provided for carrying out project work.
2	Every project batch has been allotted with guide in order to pursue with their project work.
3	Internet facility is provided to students. (CAD LAB)
4	The old project reports and the project models are kept in the project lab premises.

# [SELF ASSESSMENT REPORT]



## Mapping of Projects with PO/PSO's

S#	PROJECT NAME	PO / PSO
1	Design of car for specially - abled person	PO1,PO2,PO3,PO10,PO11,PO12/ PSO1,PSO2
2	All – Terrain vehicles	PO1,PO2,PO3,PO10,PO11,PO12/ PSO1,PSO2
3	LPG refrigerator	PO1,PO2,PO3,PO10,PO11,PO12
4	Hub less bike	PO1,PO2,PO3,PO10,PO11,PO12,PSO1
5	Compressed air engine	PO1,PO2,PO3,PO10,PO11,PO12,PSO1
6	Design and analysis of composites of piston cylinder head	PO1,PO2,PO3,PO10,PO11,PO12 / PSO2
7	Milling attachment	PO1,PO2,PO3,PO10,PO11,PO12
8	Fabrication and analysis of glass fiber composite	PO1,PO2,PO3,PO10,PO11,PO12
9	Design and Fabrication of Solar power steam Engine	PO1,PO2,PO3,PO10,PO11,PO12 / PSO2
10	Fabrication and Research on smart grinding attachment for lathe machine	PO1,PO2,PO3,PO4,PO10,PO11,PO12
11	Design and Fabrication of go cart	PO1,PO2,PO3,PO5,PO10,PO11,PO12/ PSO1,PSO2
12	Analysis of Solar vapor absorption system with different fluids	PO1,PO2,PO3,PO10,PO11,PO12
13	Analysis of fuel from plastic waste by pyrolysis Method	PO1,PO2,PO3,PO4,PO10,PO11,PO12



**DESIGN OF CAR FOR SPECIALLY - ABLED PERSON**

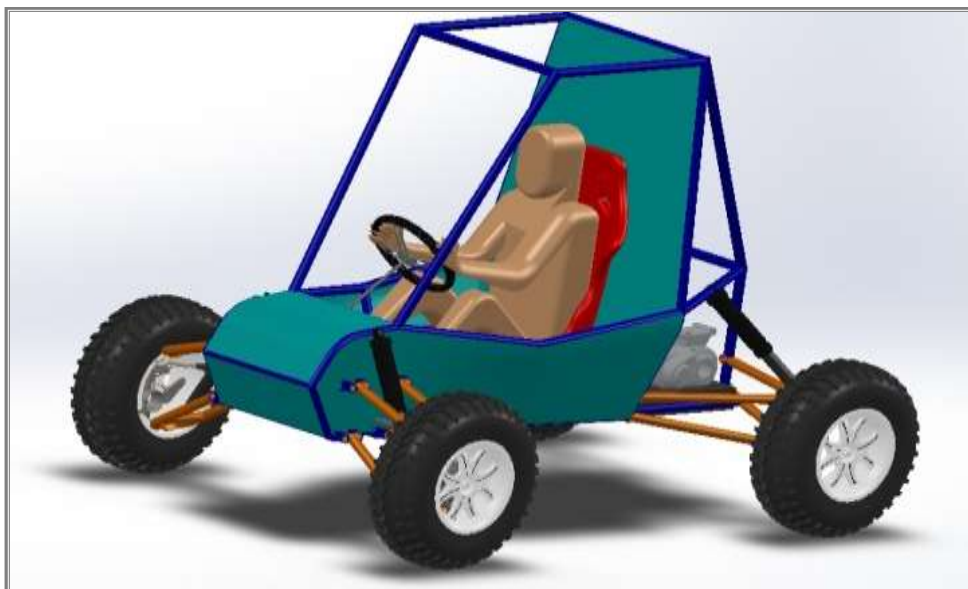

**ALL – TERRAIN VEHICLES**



**LPG REFRIGERATOR**



**HUB LESS BIKE**



**COMPRESSED AIR ENGINE**

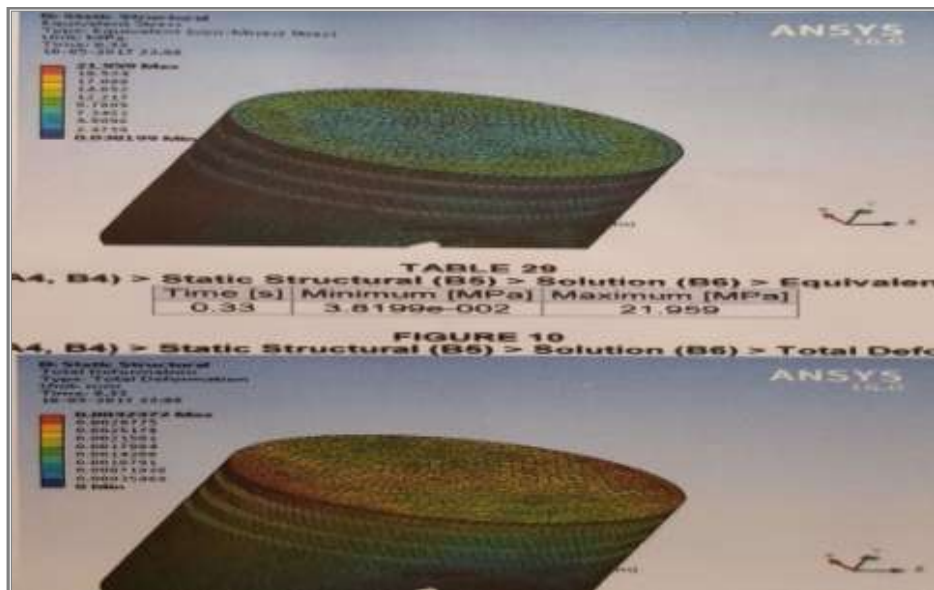

**DESIGN AND ANALYSIS OF COMPOSITES OF PISTON  
CYLINDER HEAD**



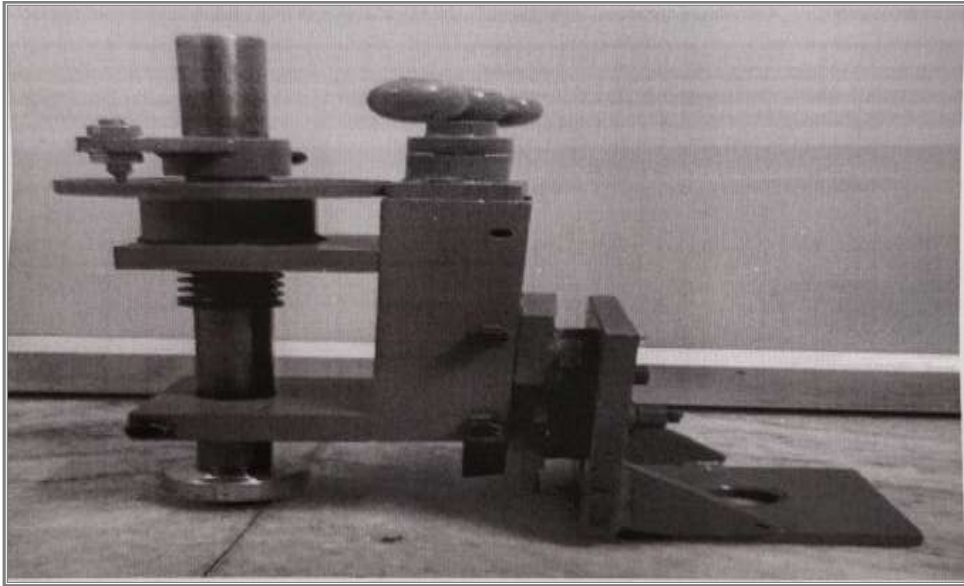

**MILLING ATTACHMENT**



**FABRICATION AND ANALYSIS OF GLASS FIBER  
COMPOSITE**



**DESIGN AND FABRICATION OF SOLAR POWER STEAM ENGINE**



**FABRICATION & RESEARCH ON SMART GRINDING ATTACHMENT FOR LATHE MACHINE**



**DESIGN AND FABRICATION OF GO CART**



**ANALYSIS OF FUEL FROM PLASTIC WASTE BY  
PYROLYSIS METHOD**



**6.5 Safety measures in laboratories: (10)**

S. No.	Safety Measures
1	The safety of equipment and wires are provided by MCB and ELCB. MCB provides protection during short circuits. Fuses provide protection from over currents. Every piece of equipment is provided with proper earthing so that it will be provide protection from internal faults
2	As the college has a multi-block academic ambience precautions have been taken for proper earthing
3	In case of fire, multiple exists should be designed to the buildings and places so that immediate evacuation is required. All the academic floors have two or more entrances / exits
4	The installed fire extinguishers were inspected and refilled after regular interval time
5	The department is provided with first aid boxes in places identified to be critical. The medical aid facility is also provided in the campus and for any serious medical issues, the hospital located within a radius of 2km from college campus
6	Welding is performed under the supervision of lab technicians and all safety measures are taken during welding process
7	Machines have safety covers over the movable parts to insure the safety of operator
8	Vibration damping pads are used during installation of machines
9	Proper gap is insured between the machines
10	Additional safety equipment must be utilized based on specific experiment requirements.

*Table B.6.5*

## [SELF ASSESSMENT REPORT]



CRITERION 7	Continuous Improvement	50
-------------	------------------------	----

### 7. CONTINUOUS IMPROVEMENT (50)

#### 7.1 Actions taken based on the results of evaluation of each of the POs (20)

##### Program Outcomes

- 1. Engineering knowledge:** Apply the knowledge of mathematics, science, engineering fundamentals, and an engineering specialization to the solution of complex engineering problems in Mechanical Engineering.
- 2. Problem analysis:** Identify, formulate, research literature, and analyze complex Mechanical Engineering problems reaching substantiated conclusions using first principles of mathematics, natural sciences, and engineering sciences.
- 3. Design/development of solutions:** Design solutions for complex Mechanical Engineering problems and design system components or processes that meet the specified needs with appropriate consideration for the public health and safety, and the cultural, societal, and environmental considerations.
- 4. Conduct investigations of complex problems:** Use research-based knowledge and research methods including design of experiments, analysis and interpretation of data, and synthesis of the information to provide valid conclusions in Mechanical Engineering.
- 5. Modern tool usage:** Create, select, and apply appropriate techniques, resources, and modern engineering and IT tools including prediction and modeling to complex Mechanical Engineering activities with an understanding of the limitations.
- 6. The engineer and society:** Apply reasoning informed by the contextual knowledge to assess societal, health, safety, legal and cultural issues and the consequent responsibilities relevant to the professional Mechanical Engineering practice.
- 7. Environment and sustainability:** Understand the impact of the professional Mechanical Engineering solutions in societal and environmental contexts, and demonstrate the knowledge of, and need for sustainable development.
- 8. Ethics:** Apply ethical principles and commit to professional ethics and responsibilities and norms of the Mechanical Engineering practice.
- 9. Individual and team work:** Function effectively as an individual, and as a member or leader in diverse teams, and in multidisciplinary settings in Mechanical Engineering.
- 10. Communication:** Communicate effectively on complex Mechanical Engineering activities with the engineering community and with society at large, such as, being able to comprehend and write effective reports and design documentation, make effective presentations, and give and receive clear instructions.
- 11. Project management and finance:** Demonstrate knowledge and understanding of the Mechanical Engineering and management principles and apply these to one's own work, as a member and leader in a team, to manage projects and in multidisciplinary environments.



12. **Life-long learning:** Recognize the need for, and have the preparation and ability to engage in independent and life-long learning in the broadest context of technological change in Mechanical Engineering.

**PSO-Program Specific outcomes**

**PSO1.** Apply the knowledge of material science, manufacturing and design to implement the various concepts of vehicle mechanics.

**PSO2.** Apply the knowledge of 3D printing technology in design and development of prototypes.

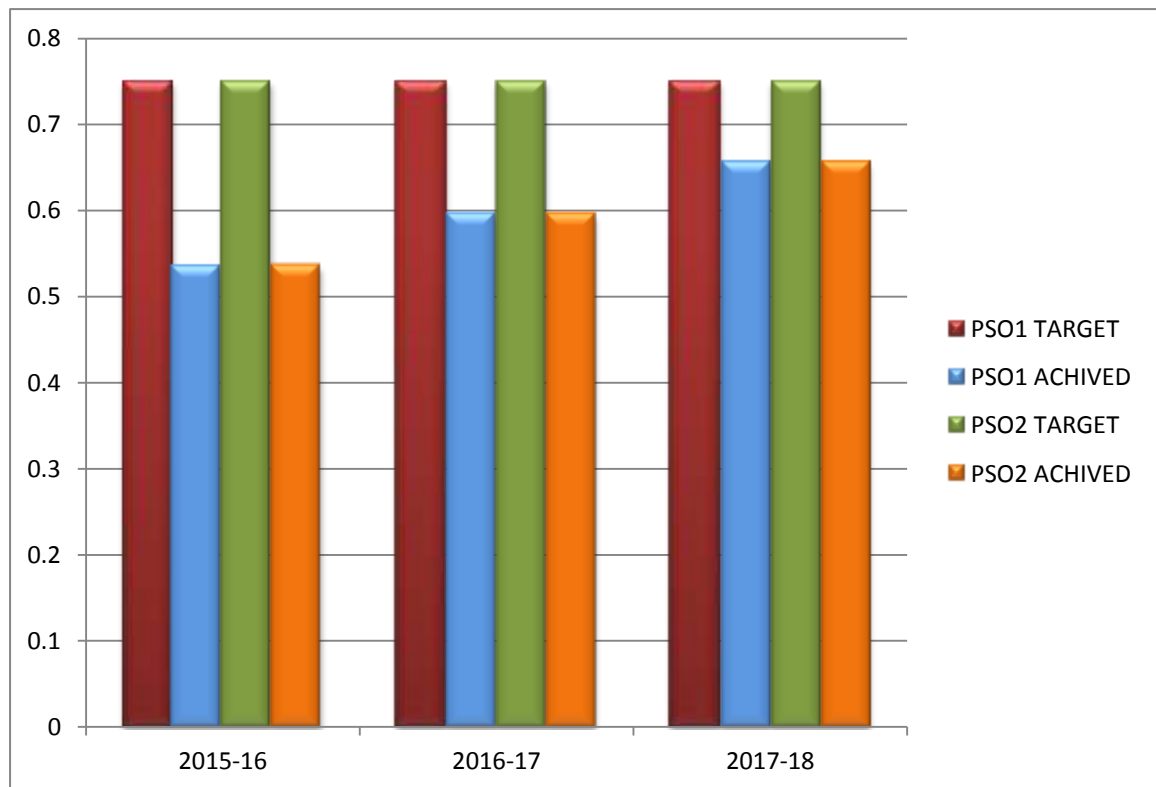

**Figure 7.1 PSOs attainment [Session 2017-18]**

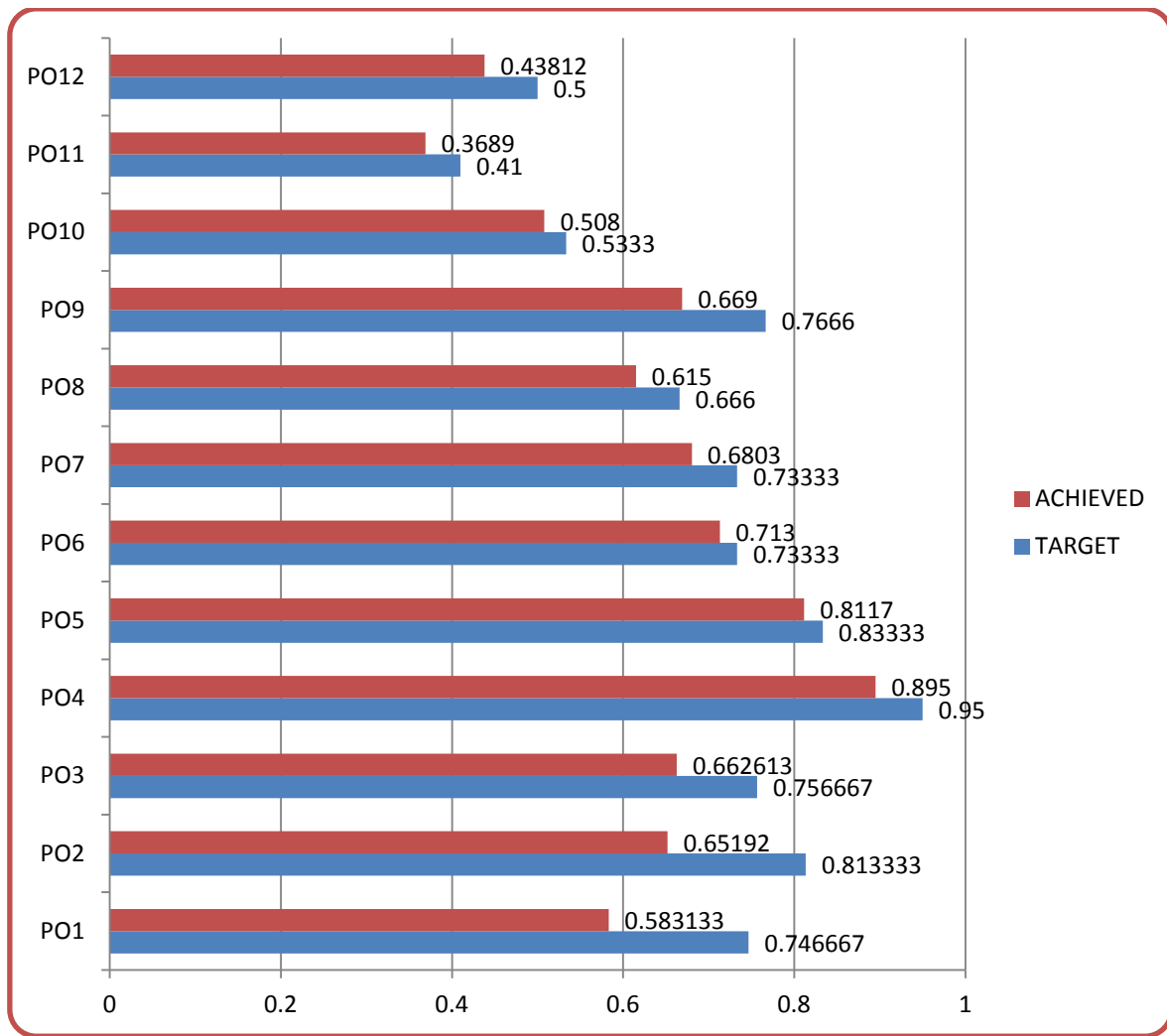

Figure 7.2 POs attainment [Session 2017-18]

Identify the areas of weaknesses in the program based on the analysis of evaluation of POs attainment levels. Planned measures identified and implemented to improve POs attainment levels for the assessment years.

## [SELF ASSESSMENT REPORT]



### PO and PSO Attainment Levels and Actions for improvement CAY: Current Academic Year 2017-18

POs	Target level	Attainment level	Observations
<b>PO1: Apply the knowledge of mathematics, science, engineering fundamentals, and an engineering specialization to the solution of complex engineering problems.</b>			
<b>PO1</b>	<b>0.746667</b>	<b>0.58333</b>	<p><b>Achieved Attainment is low</b>  <b>Observations :</b>                      1. Students (mostly lateral entry students) are not able to solve higher mathematical problems.                      2. Students are not able to apply the basic knowledge of mathematics, science, engineering fundamental in practical engineering problems.                      3. Students find it difficult to solve design related subjects.</p>
<p><b>Actions</b>  <b>(i)Following Technical activities have been organized by department to achieve the target:</b></p> <ol style="list-style-type: none"> <li>1. Guest Lecture on Stress Analysis in Practical Application</li> <li>2. Propello in which the students make their own water bottle propulsion device.</li> <li>3. Cut 2 Design in which the students make 3D objects with help of drawing.</li> <li>4. Fork Lifter in which the students make their device to lift the load.</li> <li>5. CADD mania in which the students use software to make drawing.</li> <li>6. R-mech Olympiad</li> <li>7. Brain quest</li> <li>8. Additional classes of mathematics and fundamental sciences have been conducted.</li> <li>9. Extra design and analysis classes have been conducted.</li> </ol>			

<b>PO2:Identify, formulate, research literature, and analyze complex engineering problems reaching substantiated conclusions using first principles of mathematics, natural sciences, and engineering sciences.</b>			
<b>PO2</b>	<b>0.8133333</b>	<b>0.65192</b>	<p><b>Attainment is low</b>  <b>Observation:</b>                      Students are not able to identify the causes behind the engineering problems.                      Students are not able to analysis complex engineering problems.</p>
<p><b>Actions</b>  <b>Following Technical activities have been organized by department to achieve the target:</b>                      Guest Lecture on Stress Analysis in Practical Application                      Guest Lecture on Recent Innovations in Automobile</p>			



## [SELF ASSESSMENT REPORT]



Guest lecture on Different aspects during designing of ATV.  
 Short term course on product design and development  
 Industrial Visit on Waste Management in hospital.  
 MOONRIDER Lab in which the students fabricate their own vehicle.  
 Embryo in which the students present papers.  
 Mightly Throttle in which the students make their RC-cars and held racing between teams.  
 Propello in which the students make their own water bottle propulsion device.  
 Fork Lifter in which the students make their device to lift the load.  
 CADD mania in which the students use software to make drawing.  
 R-mech Olympiad  
 Brain quest  
 International conference Recent Innovations & Technological Development in Mechanical Engineering.  
 Workshop on Assembling & Disassembling of the engine.

**PO3: Design solutions for complex engineering problems and design system components or processes that meet the specified needs with appropriate consideration for the public health and safety, and the cultural, societal, and environmental considerations.**

<b>PO3</b>	<b>0.7566667</b>	<b>0.6626</b>	<b>Attainment is low</b> <b>Observations:</b> <ol style="list-style-type: none"> <li>1. Students are not able to solve the complex engineering problems with consideration of safety, societal, and environmental for public health.</li> <li>2. Students are not able to analysis complex engineering problems.</li> <li>3. Students are not able to solve complex design problems.</li> </ol>
			<b>Actions</b> <b>Following Technical activities have been organized by department to achieve the target:</b> <ol style="list-style-type: none"> <li>1. Guest Lecture on Stress Analysis in Practical Application.</li> <li>2. Guest Lecture on Recent Innovations in Automobile.</li> <li>3. Workshop on 3-D Printing.</li> <li>4. Short term course on product design and development</li> <li>5. Industrial Visit on CAD-CAM.</li> <li>6. Industrial Visit on Waste Management in hospital</li> <li>7. Centre of Excellence Lab in which the students are learning about mechanical design software.</li> <li>8. MOONRIDER Lab in which the students fabricate their own vehicle.</li> <li>9. International conference Recent Innovations &amp; Technological Development in Mechanical Engineering.</li> <li>10. Guest lecture different aspects during designing of ATV</li> <li>11. Training on Solid works</li> <li>12. Guest lecture on Buckling analysis of mechanical components subjected to different type of loads.</li> </ol>

## [SELF ASSESSMENT REPORT]



**PO4: Use research-based knowledge and research methods including design of experiments, analysis and interpretation of data, and synthesis of the information to Provide valid conclusions.**

<b>PO4</b>	<b>0.95</b>	<b>0.895</b>	<p><b>Attainment is low</b></p> <p><b>Observations:</b></p> <p>1. Students are not able to apply research methodology to analysis and interpretation of data for solving the complex engineering problems.</p>
------------	-------------	--------------	--

**Actions**

**Following Technical activities have been organized by department to achieve the target:**

1. Guest Lecture on Stress Analysis in Practical Application
2. Guest Lecture on Recent Innovations in Automobile
3. RITDME(2016-17)International Conference
4. Embryo in which the students present papers.
5. Buckling analysis of mechanical components subjected to different type of loads.

**PO5: Create, select, and apply appropriate techniques, resources, and modern engineering and IT tools including prediction and modeling to complex engineering activities with an understanding of the limitations.**

<b>PO5</b>	<b>0.8333333</b>	<b>0.8117</b>	<p><b>Attainment is low</b></p> <p>Students are not able to create and apply techniques, resources to the complex engineering activities.</p>
------------	------------------	---------------	---

**Actions**

**Following Technical activities have been organized by department to achieve the target:**

1. Guest Lecture on Stress Analysis in Practical Application
2. Guest Lecture on Recent Innovations in Automobile
3. Workshop on 3-D Printing
4. Workshop on Assembling & Disassembling of the automobiles
5. Industrial Visit on CAD-CAM
6. Industrial Visit on Waste Management
7. Advance CNC programming for cutter/nose radius compensation
8. Buckling analysis of mechanical components subjected to different type of loads using ANSYS

**PO6: Apply reasoning informed by the contextual knowledge to assess societal, health, safety, legal and cultural issues and the consequent responsibilities relevant to the professional engineering practice.**

<b>PO6</b>	<b>0.7333333</b>	<b>0.72</b>	<p><b>Attainment is low</b></p> <p>Students are not able to apply reasoning to</p>
------------	------------------	-------------	--

## [SELF ASSESSMENT REPORT]



			safety, Legal and cultural issues.
--	--	--	------------------------------------

**Actions**

**Following Technical activities have been organized by department to achieve the target:**

1. Guest Lecture on Recent Innovations in Automobile.
2. Industrial Visit on Waste Management.
3. Social activity through “Abhudhya” Club.
4. One week awareness program regarding Road safety.
5. Some Student Projects.

**PO7: Understand the impact of the professional engineering solutions in societal and environmental contexts, and demonstrate the knowledge of, and need for Sustainable development.**

<b>PO7</b>	<b>0.7333333</b>	<b>0.6803</b>	<p><b>Attainment is low</b> It has been observed that role of students towards environment and global awareness was not satisfactory.</p>
------------	------------------	---------------	---

**Actions:**

**Following Technical activities have been organized by department to achieve the target:**

1. Guest Lecture on Recent Innovations in Automobile.
2. Industrial Visit on Waste Management.
3. Social activity through “Abhudhya” Club.
4. Some Student Projects.
5. Students are motivated to participate more in environmental awareness programs like SOCH etc.
6. Development of “App”, useful for the society.

**PO8: Apply ethical principles and commit to professional ethics and responsibilities and norms of the engineering practice.**

<b>PO8</b>	<b>0.666</b>	<b>0.615</b>	<p><b>Attainment is low</b> <b>Observations:</b> Students are not able to apply ethical principal and responsibilities towards engineering practice.</p>
------------	--------------	--------------	--

**Actions**

**Following Technical activities have been organized by department to achieve the target:**

Training on Aptitude/ group discussion/ HR training/ Reasoning, Quantitative.

**PO9: Function effectively as an individual, and as a member or leader in diverse teams, and in multidisciplinary settings.**

<b>PO9</b>	<b>0.7666</b>	<b>0.669</b>	<p><b>Attainment is low</b> <b>Observations:</b> 1. Absence of correlation among the team</p>
------------	---------------	--------------	---

## [SELF ASSESSMENT REPORT]



			<p>Members during the project work has been observed sometimes.</p> <p>2. It has been observed sometimes some students did not perform given task individual as required.</p>
--	--	--	---

**Actions:**

**Following Technical activities have been organized by department to achieve the target:**

Training on Aptitude/ group discussion/ HR training/ Reasoning, Quantitative.

J-Tectrix (project exhibition) was held.

Social activity through “Abhudhya” Club

Students are motivated to participate more in environmental awareness programs like SOCH etc.

Some Student Projects.

One week awareness program regarding Road safety.

Tech fest

**PO10: Communicate effectively on complex engineering activities with the engineering community and with society at large, such as, being able to comprehend and write effective reports and design documentation, make effective presentations, and give and receive clear instructions.**

<b>PO10</b>	<b>0.5333</b>	<b>0.508</b>	<p><b>Attainment is low</b></p> <p><b>Observations:</b></p> <p>Students are not able to present technical activities in proper way with engineering community.</p> <p>Students are not able to produce proper documents effectively of engineering activities.</p>
-------------	---------------	--------------	--

**Actions:**

**Following Technical activities have been organized by department to achieve the target:**

1. Embryo in which the students present papers.
2. Cut 2 Design in which the students make 3D objects with help of drawing.
3. CADD mania in which the students use software to make drawing.
4. H R Training
5. Group discussion
6. Project Report
7. Seminars
8. J-Tectrix (project exhibition) was held.
9. Social activity through “Abhudhya” Club.

## [SELF ASSESSMENT REPORT]



**PO11: Demonstrate knowledge and understanding of the engineering and management principles and apply these to one's own work, as a member and leader in a team, to manage projects and in multidisciplinary environments.**

<b>PO11</b>	<b>0.41</b>	<b>0.3689</b>	<b>Attainment is low</b> Some students are not able to manage project effectively.
-------------	-------------	---------------	---

**Actions:**  
**Following Technical activities have been organized by department to achieve the target:**  
 Short term course on product design and development  
 J-Tectrix (project exhibition) was held.  
 Student project  
 Moon rider club

**PO12: Recognize the need for, and have the preparation and ability to engage in Independent and life-long learning in the broadest context of technological change.**

<b>PO12</b>	<b>0.5</b>	<b>0.43812</b>	<b>Attainment is low</b> It was observed that life-long learning was not satisfactory.
-------------	------------	----------------	---

**Actions:**  
**Following Technical activities have been organized by department to achieve the target:**

1. Guest Lecture on Recent Innovations in Automobile
2. Workshop on 3-D Printing
3. Workshop on Assembling & Disassembling of the automobiles
4. Industrial Visit on Waste Management in hospital.
5. Short term course on product design and development
6. Training on Aptitude/ group discussion/ HR training/ Reasoning, Quantitative

**PSO1. Apply the knowledge of material science, manufacturing and design to implement the various concepts of vehicle mechanics.**

<b>PSO1</b>	<b>0.75</b>	<b>0.6566</b>	<b>Attainment is low</b> <b>Observations:</b> 1. Students are not able to apply the theoretical knowledge in designing the projects
-------------	-------------	---------------	---

**Actions:**  
**Following Technical activities have been organized by department to achieve the target:**

1. Guest Lecture on Different aspects during designing of ATV
2. Guest lecture on working of six stroke engine
3. Workshop on Six Stroke engine
4. Workshop on 3-D printing

## [SELF ASSESSMENT REPORT]



**PSO2. Apply the knowledge of 3D printing technology in design and development prototypes.**

<b>PSO2</b>	<b>0.75</b>	<b>0.656</b>	<p><b>Attainment is low</b>  <b>Observations:</b>                      1. Students are not able to apply the theoretical knowledge in designing the projects                      .</p>
<p><b>Actions:</b>  <b>Following Technical activities have been organized by department to achieve the target:</b></p> <ol style="list-style-type: none"> <li>1. Training on Auto Cad</li> <li>2. Training on Solid Works</li> <li>3. <b>Training on</b> Buckling analysis of mechanical components subjected to different type of loads using ANSYS</li> </ol>			

*Table B.7.1a*

Identify the areas of weaknesses in the program based on the analysis of evaluation of POs attainment levels. Planned measures identified and implemented to improve POs attainment levels for the assessment years.

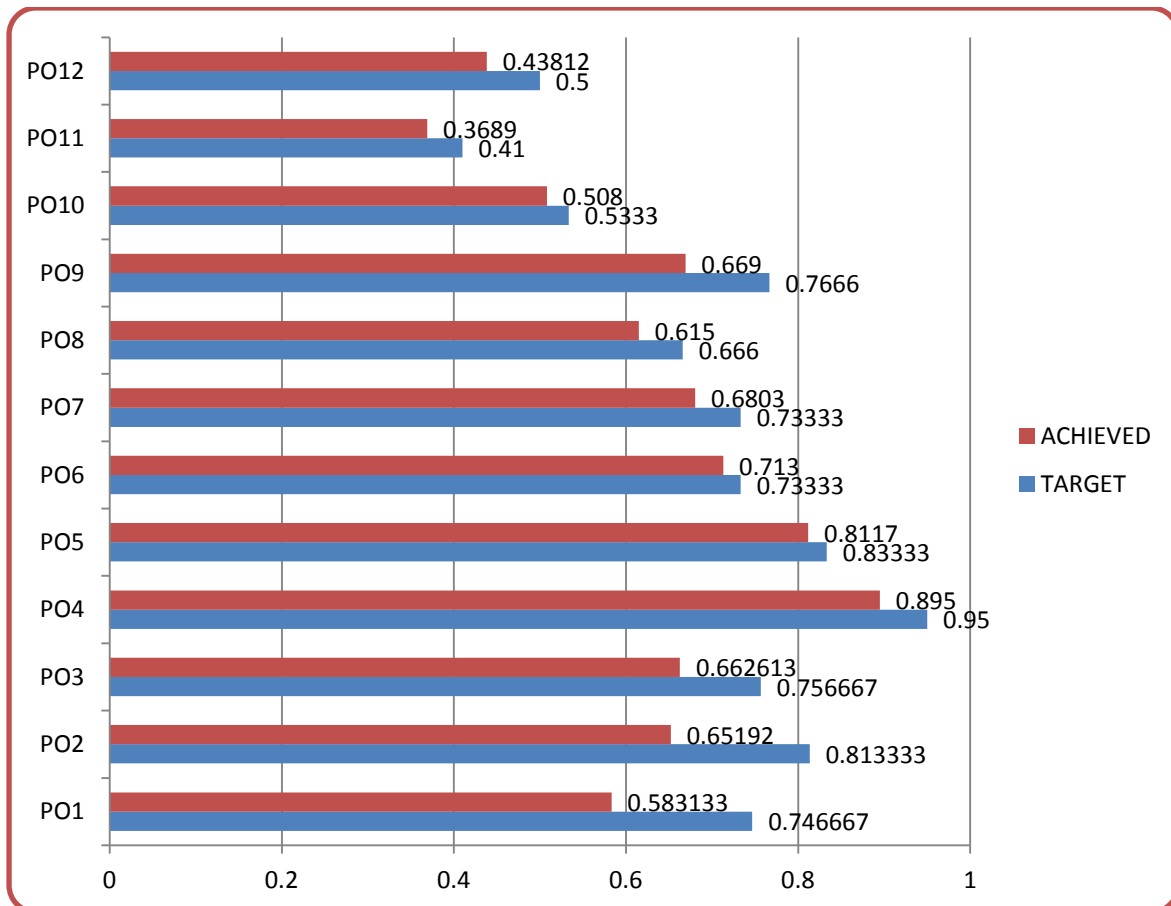

**Fig 7.3 PO Attainment (session 2016-17)**

# [SELF ASSESSMENT REPORT]



## PO and PSO Attainment Levels and Actions for improvement CAYm1: Current Academic Year minus one 2016-17

POs	Target level	Attainment level	Observations
<b>PO1: Apply the knowledge of mathematics, science, engineering fundamentals, and an engineering specialization to the solution of complex engineering problems.</b>			
<b>PO1</b>	<b>0.747</b>	<b>0.556</b>	<p><b>Achieved Attainment is low</b></p> <p><b>Observations :</b></p> <p>1 Students (mostly lateral entry students) are not able to solve higher mathematical problems.</p> <p>2. Students are not able to apply the basic knowledge of mathematics, science, engineering fundamental in practical engineering problems.</p> <p>3. Students find it difficult to solve design related subjects.</p>
<p><b>Actions</b></p> <p><b>(i)Following Technical activities have been organized by department to achieve the target:</b></p> <ol style="list-style-type: none"> <li>1. Guest Lecture on Stress Analysis in Practical Application</li> <li>2. Propello in which the students make their own water bottle propulsion device.</li> <li>3. Fork Lifter in which the students make their device to lift the load.</li> <li>4. CADD mania in which the students use software to make drawing.</li> <li>5. R-mech Olympiad</li> <li>6. Brain quest</li> <li>7. Additional classes of mathematics and fundamental sciences have been conducted.</li> <li>8. Extra design and analysis classes have been conducted.</li> </ol>			

<b>PO2:Identify, formulate, research literature, and analyze complex engineering problems reaching substantiated conclusions using first principles of mathematics, Natural sciences, and engineering sciences.</b>			
<b>PO2</b>	<b>0.813</b>	<b>0.649</b>	<p><b>Attainment is low</b></p> <p><b>Observation:</b></p> <p>Students are not able to identify the causes behind the engineering problems.</p> <p>Students are not able to analysis complex engineering problems.</p>
<p><b>Actions</b></p> <p><b>Following Technical activities have been organized by department to achieve the target:</b></p> <ol style="list-style-type: none"> <li>1. Guest Lecture on Stress Analysis in Practical Application</li> </ol>			

## [SELF ASSESSMENT REPORT]



2. Guest Lecture on Recent Innovations in Automobile
3. Guest lecture on Different aspects during designing of ATV.
4. Short term course on New Manufacturing Technologies.
5. MOONRIDER Lab in which the students fabricate their own vehicle.
6. Embryo in which the students present papers.
7. Mightly Throttle in which the students make their RC-cars and held racing between teams.
8. Propello in which the students make their own water bottle propulsion device.
9. Fork Lifter in which the students make their device to lift the load.
10. CADD mania in which the students use software to make drawing.
11. R-mech Olympiad
12. Brain quest
13. Workshop on Assembling & Disassembling of the engine.
14. Guest Lecture on Application of Advanced Thermodynamics
15. Guest Lecture on Quality Improvement of Product
16. Guest Lecture on Design of Roller Bearing
17. Conference [RESSD-2016]

**PO3: Design solutions for complex engineering problems and design system components or processes that meet the specified needs with appropriate consideration for the public health and safety, and the cultural, societal, and environmental considerations.**

<b>PO3</b>	<b>0.757</b>	<b>0.661</b>	<p><b>Attainment is low</b></p> <p><b>Observations:</b></p> <p>Students are not able to solve the complex engineering problems with consideration of safety, societal, and environmental for public health.</p> <p>Students are not able to analysis complex engineering problems.</p> <p>Students are not able to solve complex design problems.</p>
------------	--------------	--------------	---

**Actions**

**Following Technical activities have been organized by department to achieve the target:**

1. Guest Lecture on Advancement in EDM
2. Guest Lecture on Application of Advanced Thermodynamics
3. Guest Lecture on Basic introduction of Inventor
4. Guest Lecture on Design of Roller Bearing
5. Reverse Engineering
6. R-mecholympiad
7. Brain quest
8. Conference [RESSD-2016]
9. MOONRIDER Lab in which the students fabricate their own vehicle.
- 10. Guest lecture different aspects during designing of ATV**



## [SELF ASSESSMENT REPORT]



**PO4: Use research-based knowledge and research methods including design of experiments, analysis and interpretation of data, and synthesis of the information to provide valid conclusions.**

<b>PO4</b>	<b>0.95</b>	<b>0.895</b>	<p><b>Attainment is low</b>  <b>Observations:</b>                  Students are not able to apply research methodology to analysis and interpretation of data for solving the complex engineering problems.</p>
------------	-------------	--------------	---

**Actions**

**Following Technical activities have been organized by department to achieve the target:**

1. Guest Lecture on Advancement in EDM
2. Guest Lecture on Basic introduction of CREO
3. Workshop on ANSYS Training
4. Conference [RESSD-2016]
5. Embryo in which the students present papers.
6. CADD mania in which the students use software to make drawing.

**PO5: Create, select, and apply appropriate techniques, resources, and modern engineering and IT tools including prediction and modeling to complex engineering activities with an understanding of the limitations.**

<b>PO5</b>	<b>0.833</b>	<b>0.811</b>	<p><b>Attainment is low</b>                  Students are not able to create and apply techniques, resources to the complex engineering activities</p>
------------	--------------	--------------	--

**Actions**

**Following Technical activities have been organized by department to achieve the target:**

1. Guest Lecture on Advancement in EDM
2. Guest Lecture on Basic introduction of CREO
3. Guest Lecture on Quality Improvement of Product
4. Guest Lecture on Design of Roller Bearing
5. Workshop on ANSYS Training

## [SELF ASSESSMENT REPORT]



<b>PO6</b>	<b>0.733</b>	<b>0.714</b>	<p><b>Attainment is low</b> Students are not able to apply reasoning to safety, Legal and cultural issues.</p>
------------	--------------	--------------	--

**Actions**

**Following Technical activities have been organized by department to achieve the target:**

1. Guest Lecture on Advancement of Engines
2. Social activity through “Abhudhya” Club.
3. One week awareness program regarding Road safety.
4. Some Student Projects

**PO7: Understand the impact of the professional engineering solutions in societal and environmental contexts, and demonstrate the knowledge of, and need for Sustainable development.**

<b>PO7</b>	<b>0.733</b>	<b>0.678</b>	<p><b>Attainment is low</b> It has been observed that role of students towards environment and global awareness was not satisfactory.</p>
------------	--------------	--------------	---

**Actions:**

**Following Technical activities have been organized by department to achieve the target:**

1. Students are motivated to participate more in environmental awareness programs like SOCH etc.
2. Guest Lecture on Advancement of Engines
3. Workshop on Assembling and Disassembling of 2 & 4 Stroke Engines
4. Guest Lecture on Recent Innovations in Automobile.
5. Social activity through “Abhudhya” Club.
6. Some Student Projects.
7. Development of APP, useful for the society.

**PO8: Apply ethical principles and commit to professional ethics and responsibilities and norms of the engineering practice.**

<b>PO8</b>	<b>0.667</b>	<b>0.618</b>	<p><b>Attainment is low</b> <b>Observations:</b> Students are not able to apply ethical principal and responsibilities towards engineering practice.</p>
------------	--------------	--------------	--

**Actions**

**Following Technical activities have been organized by department to achieve the target:**

1. Training on Aptitude/ group discussion/ HR training/ Reasoning, Quantitative.
2. Guest Lecture on Career Counseling.

## [SELF ASSESSMENT REPORT]



**PO9: Function effectively as an individual, and as a member or leader in diverse teams, and in multidisciplinary settings.**

<b>PO9</b>	<b>0.767</b>	<b>0.687</b>	<p><b>Attainment is low</b></p> <p><b>Observations:</b></p> <p>1. Absence of correlation among the team Members during the project work has been observed sometimes.</p> <p>2. It has been observed sometimes some students did not perform given task individual as required.</p>
------------	--------------	--------------	--

**Actions:**

**Following Technical activities have been organized by department to achieve the target:**

1. Training on Aptitude/ group discussion/ HR training/ Reasoning, Quantitative.
2. J-Tectrix (project exhibition) was held.
3. Social activity through “Abhudhya” Club
4. Students are motivated to participate more in environmental awareness programs like SOCH etc.
5. Some Student Projects.
6. One week awareness program regarding Road safety.
7. Tech fest.

**PO10: Communicate effectively on complex engineering activities with the engineering community and with society at large, such as, being able to comprehend and write effective reports and design documentation, make effective presentations, and give and receive clear instructions.**

<b>PO10</b>	<b>0.5333</b>	<b>0.517</b>	<p><b>Attainment is low</b></p> <p><b>Observations:</b></p> <p>Students are not able to present technical activities in proper way with engineering community.</p> <p>Students are not able to produce proper documents effectively of engineering activities.</p>
-------------	---------------	--------------	--

**Actions:**

**Following Technical activities have been organized by department to achieve the target:**

1. Embryo in which the students present papers.
2. CADD mania in which the students use software to make drawing.
3. H R Training
4. Group discussion
5. Project Report
6. Seminars
7. Social activity through “Abhudhya” Club.

## [SELF ASSESSMENT REPORT]



**PO11: Demonstrate knowledge and understanding of the engineering and management principles and apply these to one's own work, as a member and leader in a team, to manage projects and in multidisciplinary environments.**

<b>PO11</b>	<b>0.41</b>	<b>0.372</b>	<b>Attainment is low</b> Some students are not able to manage project effectively.
-------------	-------------	--------------	---

**Actions:**

**Following Technical activities have been organized by department to achieve the target:**

1. Short term course on New Manufacturing Technologies
2. J-Tectrix (Project Exhibition) was held.
3. Student project
4. Moon rider club

**PO12: Recognize the need for, and have the preparation and ability to engage in independent and life-long learning in the broadest context of technological change.**

<b>PO12</b>	<b>0.5</b>	<b>0.434</b>	<b>Attainment is low</b> It was observed that life-long learning was not satisfactory.
-------------	------------	--------------	---

**Actions:**

**Following Technical activities have been organized by department to achieve the target:**

1. Guest Lecture on Recent Innovations in Automobile
2. Workshop on Assembling & Disassembling of the automobiles
3. Short term course on product design and development
4. Training on Aptitude/ group discussion/ HR training/ Reasoning, Quantitative
5. Guest Lecture on Career Counseling
6. Guest Lecture on Advancement of Engines
7. Guest Lecture on Quality Improvement of Product
8. Embryo in which the students present papers.
9. Mightily Throttle in which the students make their RC-cars and held racing between teams.

**PSO1. Apply the knowledge of material science, manufacturing and design to implement the various concepts of vehicle mechanics.**

<b>PSO1</b>	<b>0.75</b>	<b>0.596</b>	<b>Attainment is low</b> <b>Observations:</b> 1. Students are not able to solve practical problems related to automobile.
-------------	-------------	--------------	---

**Actions:**

**Following Technical activities have been organized by department to achieve the target:**

1. Guest Lecture on Different aspects during designing of ATV
2. Guest lecture on working of six stroke engine
3. Workshop on Six Stroke engine
4. Workshop on 3-D printing



**PSO2. Apply the knowledge of 3D printing technology in design and development prototypes.**

<b>PSO2</b>	<b>0.75</b>	<b>0.596</b>	<p><b>Attainment is low</b></p> <p><b>Observations:</b></p> <p>1. Students are facing the problems in designing and analysis of mechanical components.</p>
<p><b>Actions:</b></p> <p><b>Following Technical activities have been organized by department to achieve the target:</b></p> <ol style="list-style-type: none"> <li>1. Guest Lecture on Basic introduction of CREO</li> <li>2. Guest Lecture on basic introduction of inventor</li> <li>3. Guest Lecture on Design consideration during design of roller bearing and testing of different types of bearing</li> <li>4. Workshop on Buckling analysis of mechanical components subjected to different type of loads</li> </ol>			

*Table B.7.1b*

**7.2 Academic Audit and Action Taken therefore during the period of Assessment (10)**

**Academic audit**

The Departments of any institution are the backbone of the core business of any institution where the basic activities i.e. teaching, research and service are conducted. To enhance the quality of the Programs in terms of program objectives and to ensure graduate attributes as program outcomes which are defined by each department the academic audit reviews the processes and procedures used by departments.

The main focus of the academic audit is on the following areas

Defining intended Course and Program Outcomes

Designing effective teaching and learning processes

Developing and using outcome based student assessment

Assuring implementation of quality education - significant activities such as research and services, co- curricular and extracurricular activities to support program outcomes

**.Objectives of Academic Audit**



1. To enhance the teaching and learning process and to ensure quality of technical education throughout the system
2. To take care functionalities of technical education.
3. To provide feedback mechanism used for assessing the performance of teachers by students and for curricular development.
4. To provide Computer, internet and library facilities available.

### **1. Internal Quality Assurance Committee**

- Prepare and finalize the PEOs and POs/PSOs, Align them with the Mission and write the process of development of PEOs and POs
- Supervises the COs and their alignment to POs, assignments, tests, quiz, activities, Bloom's Taxonomy and ensures targets set by faculty are realistic.
- Review assessment of Course Outcomes and their relationship with POs/PSOs
- HOD collects recommendations and suggestions and through department InternalQuality Assurance Committee come out with implementable actions or items points for continuous improvements of POs and PEOs
- HOD presents report to principal with resource requirements and academic directions
- For direct assessment collects the student results for respective courses aligned to the PO and analyze the average achievement of performance
- Collects recommendations for improvements

### **Quality of internal semester Question papers, Assignments and Evaluation**

Ensure the paper is fulfilling the Cos requirements and assess the paper according to the syllabus.

Samples answer sheets are taken for the scrutinization of the answer sheet randomly.

### **Question papers**

- To ensure the quality of internal semester question papers, solution of question papers and scrutinization of answer sheets, the department has drafted a committee named as **Moderation and scrutinizing Committee**. The following members being the part of this Committee: The information related to Moderation and scrutinizing Committee is given in table.

## [SELF ASSESSMENT REPORT]



### Moderation and scrutinizing Committee (2018-19)

S#	Faculty	Qualification	Designation	Role
1	Dr. M.P. Singh	B.E, M.Tech, Ph.D	HOD	Chair
2	Dr.Fauzia Siddiqui	B.Tech, M.Tech, Ph.D	Professor	Member
3	Dr. Bhuvnesh Bhardwaj	B.E, M.Tech, Ph.D	Associate Professor	Member
4	Dr. Manish Shrivastava	B.E, M.Tech, Ph.D	Assistant Professor	Member

### Moderation and scrutinizing Committee (2017-18)

S#	Faculty	Qualification	Designation	Role
1	Dr. M.P. Singh	B.E, M.Tech, Ph.D	HOD	Chair
2	Mr. Manish Jain	B.E, M.Tech, Ph.D (Pur.)	Associate Professor	Member
3	Dr. Bhuvnesh Bhardwaj	B.E, M.Tech, Ph.D	Associate Professor	Member
4	Dr. Manish Shrivastava	B.E, M.Tech, Ph.D	Assistant Professor	Member

### Moderation and scrutinizing Committee (2016-17)

S#	Faculty	Qualification	Designation	Role
1	Mr. Manish Jain	B.E, M.Tech, Ph.D (Pur.)	HOD	Chair
2	Dr. M.P. Singh	B.E, M.Tech, Ph.D	Professor	Member
3	Dr. Bhuvnesh Bhardwaj	B.E, M.Tech, Ph.D	Associate Professor	Member
4	Dr. Manish Shrivastava	B.E, M.Tech, Ph.D	Assistant Professor	Member

# [SELF ASSESSMENT REPORT]



## Moderation and scrutinizing Committee (2015-16)

S#	Faculty	Qualification	Designation	Role
1	Mr. Manish Jain	B.E, M.Tech, Ph.D (Pur.)	HOD	Chair
2	Mr. Lalit Kumar Sharma	B.E, M.Tech,	Assistant Professor	Member
3	Mr. Bhuvnesh Bhardwaj	B.E, M.Tech, Ph.D(Pur.)	Assistant Professor	Member
4	Dr. Manish Shrivastava	B.E, M.Tech, Ph.D	Assistant Professor	Member

### Workshop and Lab In charge

Ensure the availability of raw material and equipment for the experiments and the working of the machine to perform the practical.

Maintain the stock register and continuous record is maintained.

### 7.3 Improvement in Placement, Higher Studies and Entrepreneur (10)

Assessment is based on improvement in:

- Placement: number, quality placement, core industry, pay packages etc.
- Higher studies: performance in GATE, GRE, GMAT, CAT etc., and admissions in premier institutions.

Item	CAY (2017-18)	CAYm1 (2016-17)	CAYm2 (2015-16)
Total No. of Final Year Students (N)	146	149	151
No. of students placed in companies or Government Sector (x)	74	77	84
No. of students admitted to higher studies with valid qualifying scores (GATE or equivalent State or National Level Tests, GRE, GMAT etc.) (y)	2	3	8
No. of students turned entrepreneur in engineering/technology (z)	5	4	4
$x + y + z =$	81	84	96
Placement Index : $(x + y + z) / N$	0.56	0.56	0.64
Average placement = $(P1 + P2 + P3) / 3$	0.58		
Assessment Points = $40 \times$ average placement	23.39		





**7.4 Improvement in the quality of students admitted to the programme (10)**

Assessment is based on improvement in terms of ranks/score in qualifying state level/national level entrances tests, percentage Physics, Chemistry and Mathematics marks in 12<sup>th</sup> standard and percentage marks of the lateral entry student.

Item		CAY (2017-2018)	CAYm1 (2016-2017)	CAYm2 (2015-2016)
National Level Entrance Examination (JEE)	No. of Students admitted	145	138	131
	Opening Score/Rank	198	147	739 (Rank)
	Closing Score/Rank	46	89	4836 (Rank)
State/ University/ Level Entrance Examination/ Others	No. of Students admitted	N/A	N/A	N/A
	Opening Score/Rank	N/A	N/A	N/A
	Closing Score/Rank	N/A	N/A	N/A
Name of the Entrance Examination for Lateral Entry or Lateral entry details	No. of Students admitted	22	14	9
	Opening Score/Rank	-----	-----	-----
	Closing Score/Rank	-----	-----	-----

**Table B.7.4**

## [SELF ASSESSMENT REPORT]



CRITERION 8	First Year Academics	50
-------------	----------------------	----

### **8.1 First Year student faculty Ratio (5)**

**Data for first year courses to calculate FYSFR**

Year	No. of students (Approved intake strength)	No. of faculty members (Considering fractional load)	FYSFR	Assessment = (5×20)/Average FYSFR (Limited to Max. 5)
CAYp1: 2018-19	990	46	21.52	4.64
CAY: 2017-18	997	48	20.77	4.81
CAYm1: 2016-17	1020	51	20.00	5.00
<b>Average</b>	<b>1002</b>	<b>48.33</b>	<b>20.76</b>	<b>4.81</b>

**Table B. 8.1**

### **8.2 Qualification of Faculty Teaching First Year Common Courses (5)**

Assessment of qualification =  $(5X+3Y)/RF$ , X = No. of Regular Faculty with Ph.D., Y = No. of Regular Faculty with Post Graduate qualification, RF = No. of faculty members required as per SFR of 20:1, faculty definition as define in 5.1

Year	X	Y	RF	Assessment of faculty qualification (5X+3Y)/RF
CAYp1: 2018-19	22	24	49.50	3.67
CAY: 2017-18	24	24	49.85	3.85
CAYm1: 2016-17	29	22	51.00	4.13
Average Assessment				<b>3.88</b>

**Table B. 8.2**

### **8.3 First Year Academic Performance (10)**

*Academic Performance = ((Mean of 1st Year Grade Point Average of all successful Students on a 10 point scale) or (Mean of the percentage of marks in First Year of all successful students/10)) x(number of successful students/number of students appeared in the examination)*

Successful students are those who are permitted to proceed to the second year.

First Year Academic Performance is shown in the table below:

S. No.	CAY	Academic Performance (10 Scale)
1	CAYp1: 2018-19	Result yet to be declared
2	CAY: 2017-18	7.9
3	CAYm1: 2016-17	7.9

Table 8.3a Academic Performance (10 Scale)

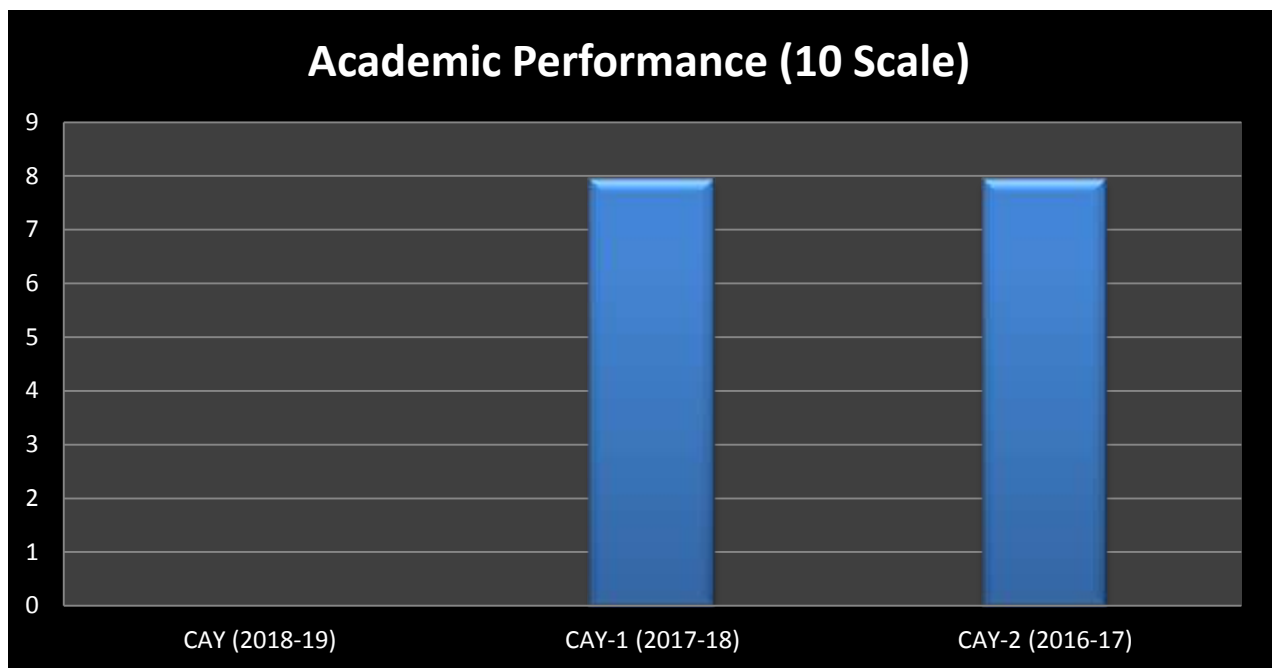

Figure 8.3(a) Academic Performance (10 Scale)

# [SELF ASSESSMENT REPORT]



Session: 2017-18 (II Sem)

S. No	SUBJECT	No. of Students	Passed	Mean of %	10 scale
1	Communication Skills	524	517	98.66	9.7
2	Human Values	486	476	97.94	9.6
3	Engineering Chemistry	469	398	84.86	7.2
4	Engineering Physics	500	438	87.60	7.7
5	Engineering Mathematics-II	964	874	90.66	8.2
6	Basic Civil Engineering	861	794	92.22	8.5
7	Computer Programming-II	984	826	83.94	7.0
8	Engineering Mechanics	1016	831	81.79	6.7
9	Basic Mechanical Engineering	127	91	71.65	5.1
	<b>AVERAGE</b>	<b>656</b>	<b>583</b>	<b>87.70</b>	<b>7.7</b>

Table B.8.3b Academic Performance 2017-18 Sem.-II

Session: 2017-18 (Sem.-I)

S. No.	Subject	No. of Students	Passed	Mean of %	10 Scale
1	Communication Skills	490	484	98.78	9.8
2	Human Values	523	500	95.60	9.1
3	Engineering. Chemistry	511	464	90.80	8.2
4	Engineering Physics	474	379	79.96	6.4
5	Engineering Mathematics I	974	794	81.52	6.6
6	Environmental Engineering and Disaster Management	986	930	94.32	8.9
7	Computer Programming	994	892	89.74	8.1
	<b>AVERAGE</b>	<b>707</b>	<b>635</b>	<b>90.10</b>	<b>8.1</b>

Table B.8.3c Academic Performance 2017-18 Sem.-I

## [SELF ASSESSMENT REPORT]



Session: 2016-17 (Sem. - II)

S. No.	Subject	No. of Students	Passed	Mean of %	10 Scale
1	Communication Techniques	1001	993	99.20	9.8
2	Engineering Mathematics-II	992	791	79.74	6.4
3	Engineering Physics-II	1005	880	87.56	7.7
4	Chemistry & Environmental Engineering	1001	936	93.51	8.7
5	Engineering Mechanics	1001	866	86.51	7.5
6	Fundamentals of Computer Programming	976	808	82.79	6.9
<b>AVERAGE</b>		<b>996</b>	<b>879</b>	<b>88.21</b>	<b>7.8</b>

Table B.8.3d Academic Performance 2017-18 Sem.-II

Session: 2016-17 (Sem.-I)

S. No.	Subject	No. of Students	Passed	Mean of %	10 Scale
1	Communicative English	1015	965	95.07	9.0
2	Engineering Mathematics-I	1014	822	81.07	6.6
3	Engineering Physics-I	1009	803	79.58	6.3
4	Engineering Chemistry-I	1014	959	94.58	8.9
5	Basic Electrical and Electronics Engineering	1019	875	85.87	7.4
<b>AVERAGE</b>		<b>1014</b>	<b>885</b>	<b>87.23</b>	<b>7.6</b>

Table B.8.3e Academic Performance 2016-17 Sem.-I

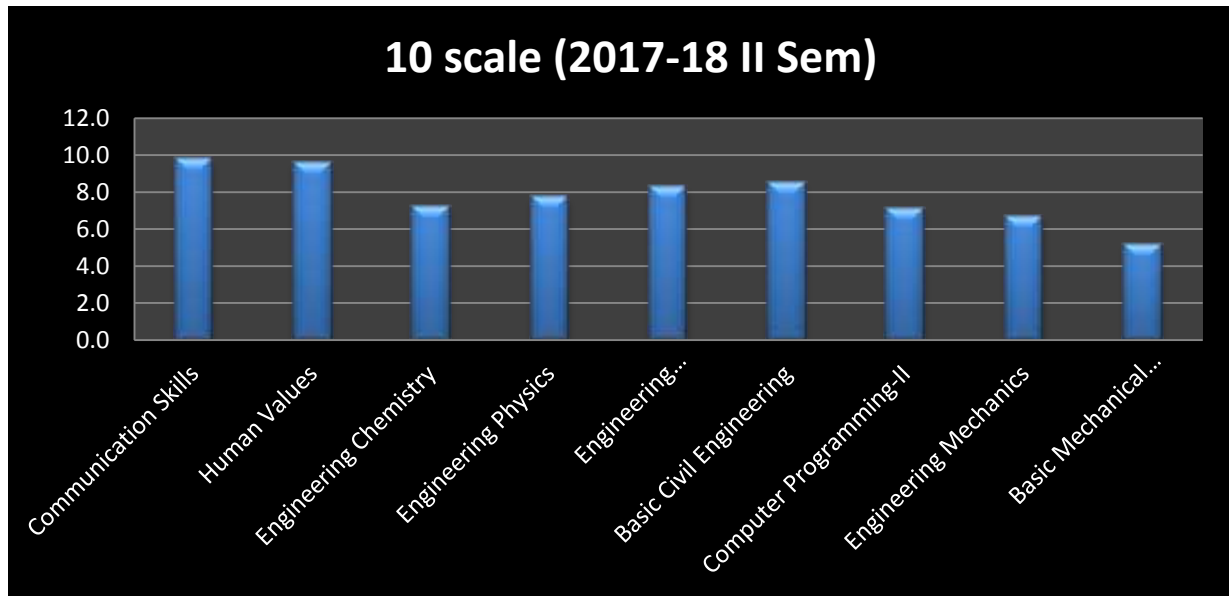

Figure 8.3b Academic Performance 2017-18 I Sem. (10 Scale)

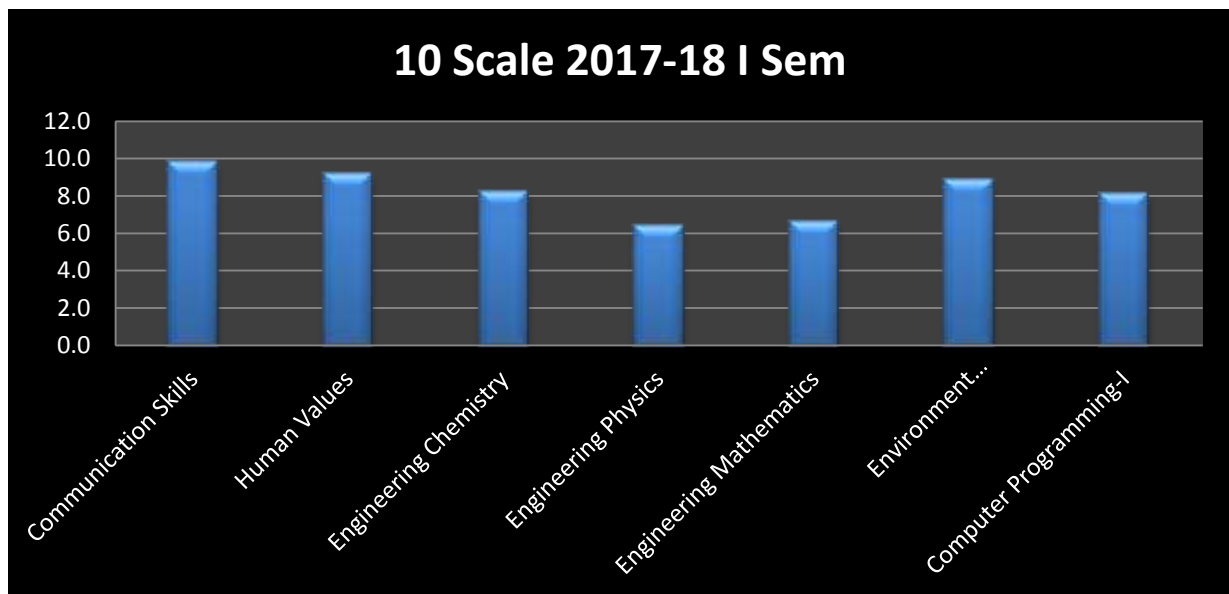

Figure 8.3c Academic Performance 2017-18 I Sem. (10 Scale)

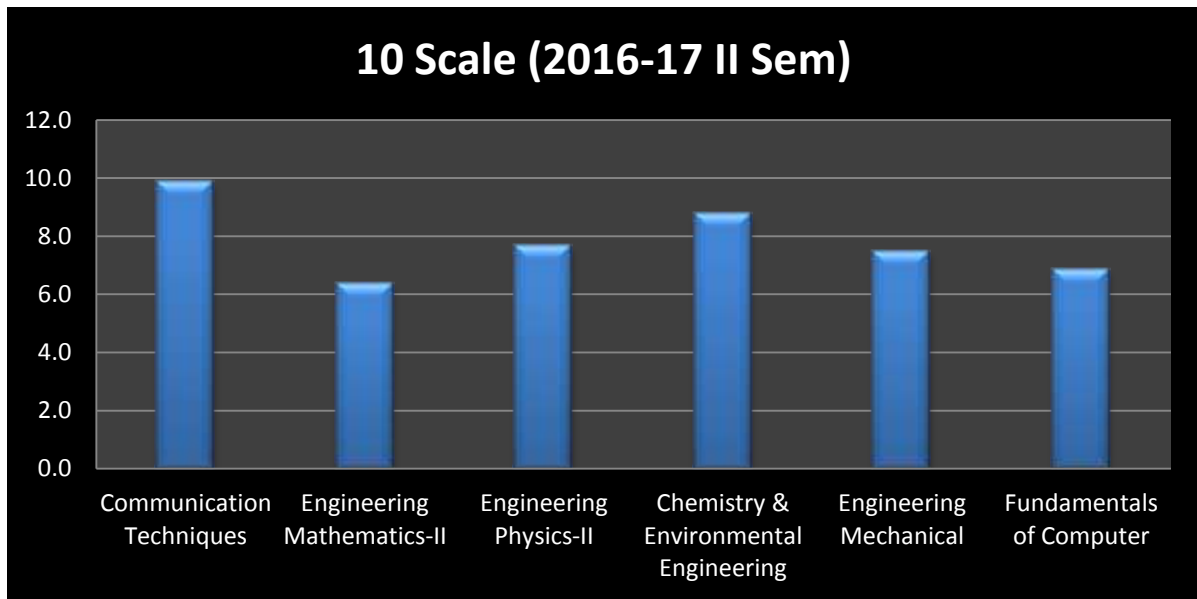

Figure 8.3d Academic Performance 2016-17 II Sem. (10 Scale)

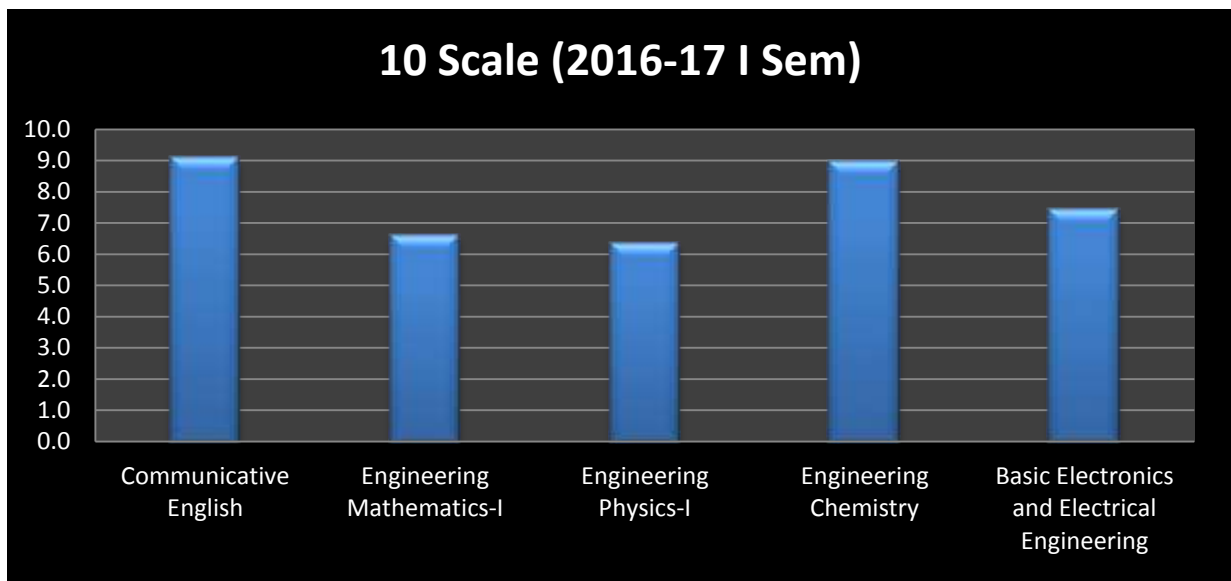

Figure 8.3e Academic Performance 2016-17 I Sem. (10 Scale)

**8.4. Attainment of Course Outcomes of first year courses (10)**

**8.4.1. Describe the assessment processes used to gather the data upon which the evaluation of Course Outcomes of first year is done (5)**

*(Examples of data collection processes may include, but are not limited to, specific exam questions, laboratory tests, internally developed assessment exams, oral exams assignments, presentations, tutorial sheets etc.)*

**The assessment process used to gather the data upon which the evaluation of courseoutcomes of first year is done is as follows:**

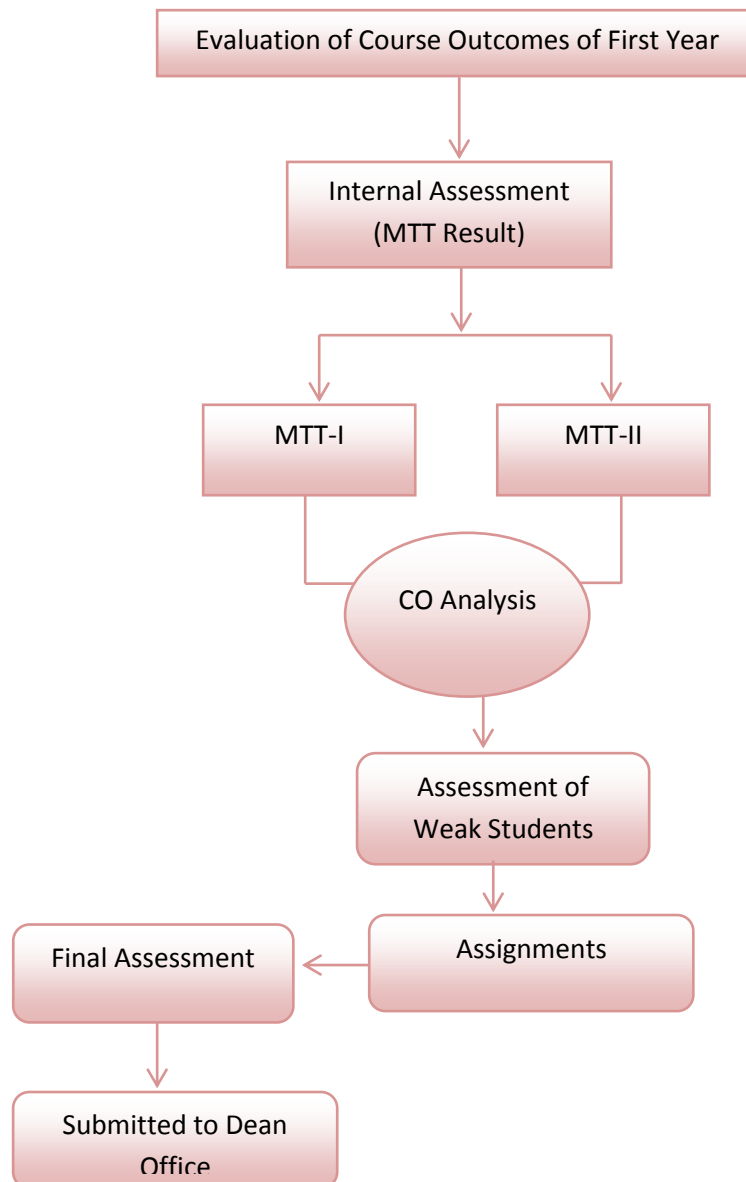

**Figure 8.4a Attainment of Course Outcome of First Year Course**





### **Assessment Process for the Year 2018-19**

- Internal assessment will be done by taking two Mid Term Tests and assignment/presentations (co wise) as per the RTU guidelines.
- The performance of a student in internal assessment with respect to all the CO's will be recorded.
- End semester University exam performance of students for the maximum marks will be considered for external exam performance.
- For laboratory assessment, the over all performance of a student in sessional will be assessed as in Final lab internal test, Final lab internal Viva voce and Class performance during the whole semester (record + attendance). Total of these three is considered for internal lab assessment.
- Performance of a student in external lab exam i.e. Practical will be assessed as in performance and viva voce. Total of this is considered for external practical exam performance.
- The summation of these two performances is considered as cumulative assessment for a prescribed lab outcome.

### **Assessment Process for the Year 2016-17 & 2017-18**

- Two internal tests for a maximum marks 10 are conducted and total of two internals is considered for final internal assessment.
- The performance of a student in internal assessment with respect to all the CO's is recorded.
- End semester University exam performance of students for the maximum marks 100 is considered for external exam performance.
- For laboratory assessment, the over all performance of a student in sessional is assessed as in Final lab internal test, Final lab internal Viva voce and Class performance during the whole semester (Record + attendance). Total of these three is considered for internal lab assessment.
- Performance of a student in external lab exam i.e. Practical is assessed as in performance and viva voce. Total of this is considered for external practical exam performance.
- The summation of these two performance is considered as cumulative assessment for a prescribed lab outcome.

**8.4.2. Record the attainment of Course Outcomes of all first year courses (5)**

Program shall have set attainment levels for all first year courses.

*(The attainment levels shall be set considering average performance levels in the university examination or any higher value set as target for the assessment years. Attainment level is to be measured in terms of student performance in internal assessments with respect the COs of a subject plus the performance in the University examination)*

**Attainment of Course Outcome**

**Target for Assessment Year 2017-2018 = 60%**

**Semester I (Session: 2017-2018)**

S. No.	Subject	CO1	CO2	CO3	CO4	Average Attainment
1	Communication Skills (HU-101)	79.63%	67.70%	82.10%	-	76.47%
2	Human Values (HU-103)	75.38%	66.79%	76.15%	-	72.77%
3	Engineering Mathematics-I(MA-101)	70.92	75.60	51.43	44.78	60.68%
4	Engineering Physics (PY-101)	70.75	69.55	73.53	-	71.28%
5	Engineering Chemistry (CY-101)	77.31%	66.07%	72.43%	69.42%	71.30%
6.	Computer Programming-I(CS-101)	48.2	51.1	47.3	53.5	50%%
7.	Environmental & Disaster Management(CE-101)	89.15	90.30	85.71	82.88	87.01%

**Table B.8.4.2a Attainment of Course Outcome Semester I (2017-2018)**

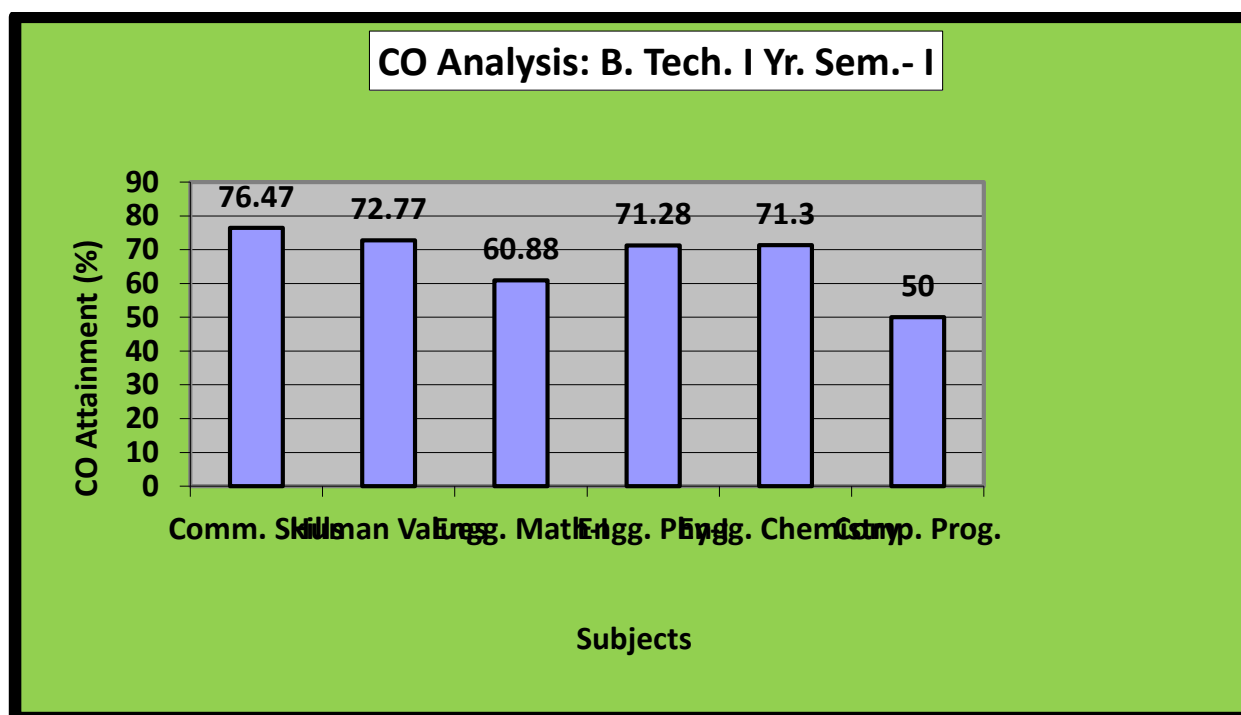

Figure 8.4.2a CO Analysis B.Tech I Yr. Sem.-I (2017-18)

Target for Assessment Year 2017-2018= 60%

Semester II (Session: 2017-2018)

S. No.	Subject	CO1 (in %)	CO2	CO3	CO4	Average Attainment
1.	Communication Skills (HU-101)	80.34	55.91	87.21	-	74.48
2.	Human Values (HU-103)	70.49	67.62	73.15	-	70.42
3.	Engineering Mathematics-I(MA-101)	81%	59%	79%	39%	65%
4.	Engineering Physics (PY-101)	<b>76.57</b>	<b>75.45</b>	<b>79.05</b>	--	<b>77.04</b>
5.	Engineering Chemistry (CY-101)	60.83	43.99	71.16	52.73	57.18
6.	Computer Programming-I(CS-101)	65.83	58.14	66.86	64.11	63.73
7.	Basic Mechanical Engineering (ME-101)	82.38	87.32	-	-	84.85
8.	Basic Civil Engineering (CE-103)	85.07	83.23	66.75	76.64	
9.	Engineering Mechanics (OE-101)	80	78.57	87.96	56.94	75.87

Table B.8.4.2b Attainment of Course Outcome Semester I (2017-2018)

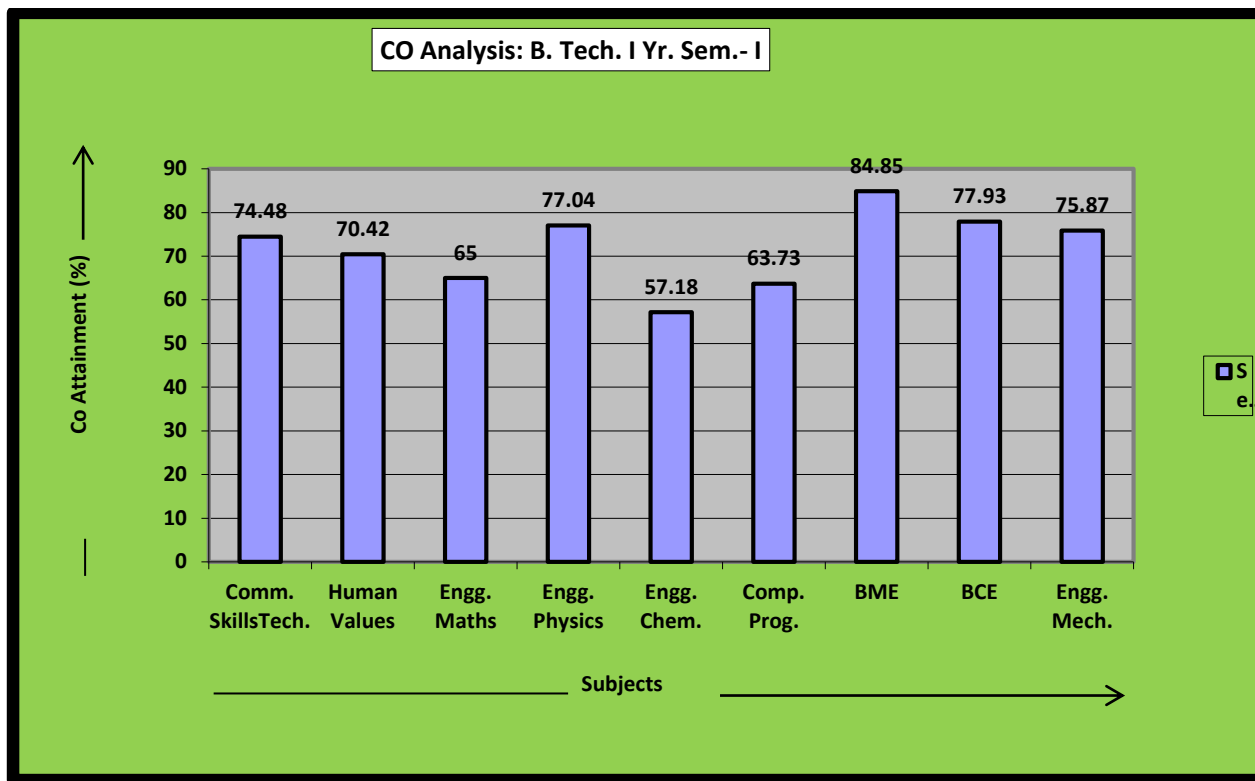

Figure 8.4.2b CO Analysis B.Tech I Yr. Sem.-II (2017-18)

Target for Assessment Year 2016-2017= 60%

Semester I (Session: 2016-2017)

S. No.	Subject	CO1	CO2	CO3	CO4	CO5	Average Attainment
1	Communicative English(101)	82.36	78.81	80.09	-	-	80.39
2	Engineering Mathematics-I(102)	70.73	49.99	61.93	-	-	60.88
3	Engineering Physics-I(103)	92.68	82.05	-	-	-	87.37
4	Engineering Chemistry(104)	86.53	79.66	57.54	---	---	74.57
5	Basic Electrical & Electronics Engg.(105)	54.27	44.04	42.43	47.81	52.5	48.20

Table B.8.4.2c Attainment of Course Outcome Semester I (2016-2017)

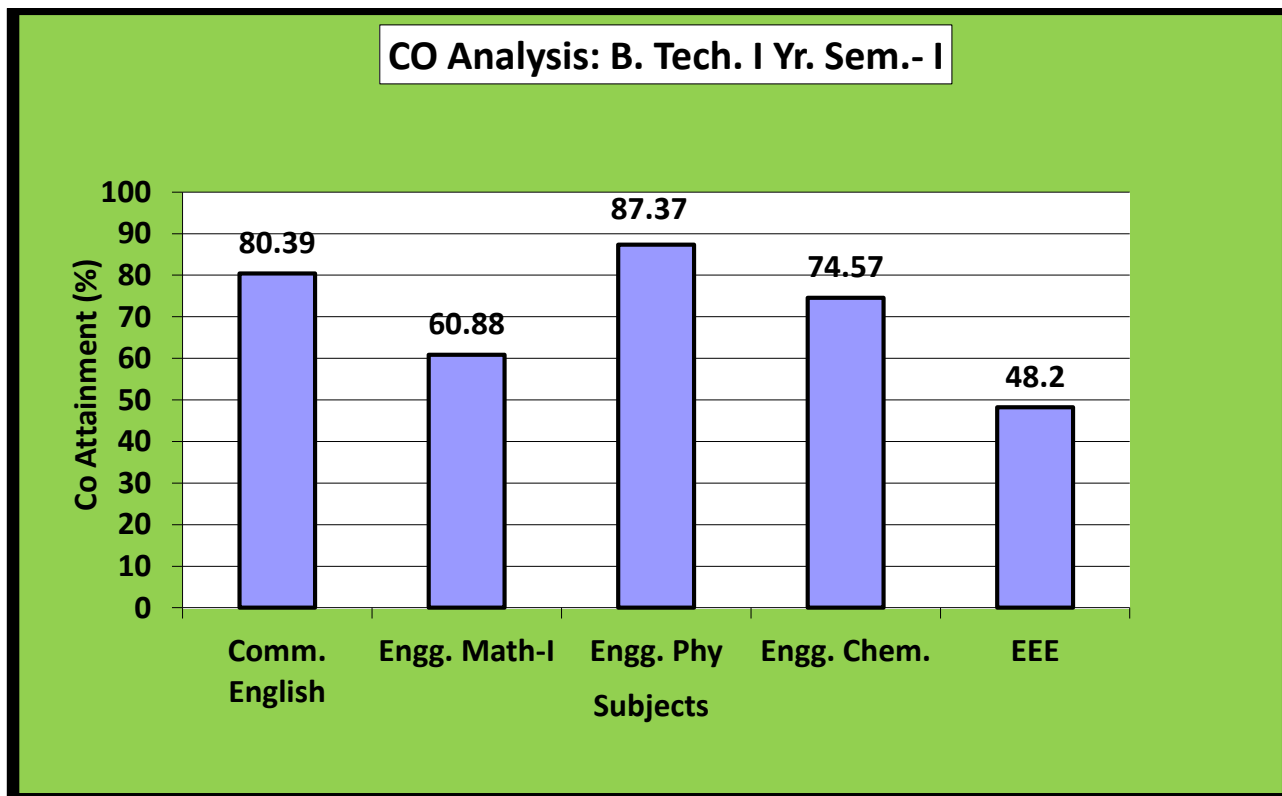
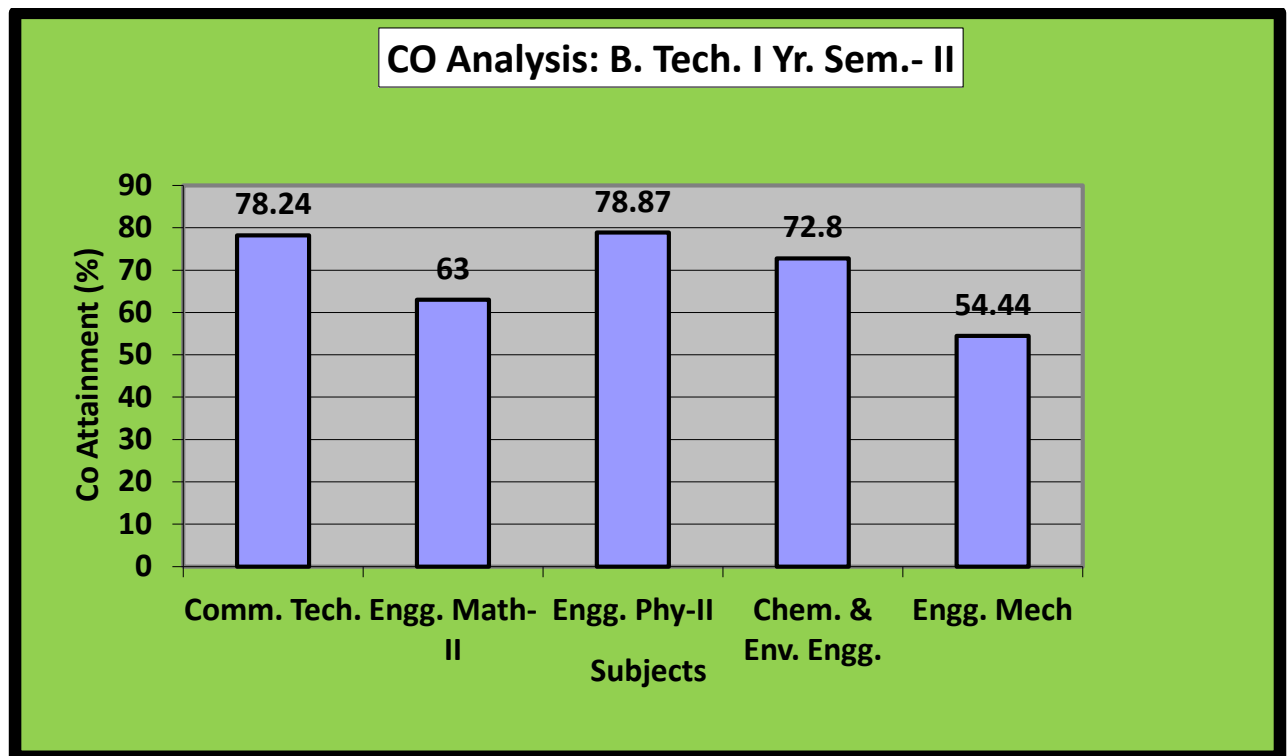

Figure 8.4.2c CO Analysis B.Tech I Yr. Sem.-I (2016-17)

Target for Assessment Year 2016-2017= 60%  
Semester II (Session: 2016-2017)

S.No.	Subject	CO1	CO2	CO3	CO4	CO5	Average Attainment
1	Communication Technique(201)	76.22	84.41	74.11	-	-	78.24
2	Engineering Mathematics-II(202)	67	82	66	37	-	63
3	Engineering Physics-II(203)	77.26	80.48	-	-	-	78.87
4	Chemistry & Environmental	85.74	68.96	63.76	-	-	72.8
5	Engineering Mechanics(205)	60.33	48.56	-	-	-	54.44
6	Fundamentals of Computer Programming(206)	77	60.5	79.3	53.8		67.65

Table B.8.4.2d Attainment of Course Outcome Semester II (2016-17)



**Figure 8.4.2d CO Analysis B.Tech I Yr. Sem.-II (2016-17)**

### 8.5: Attainment of Program Outcomes from I year courses (20)

#### 8.5.1: Indicate results of evaluation of each relevant PO and/or PSO, if applicable (15)

*The relevant Program outcomes that are to be addressed at first year need to be identified by the institution.*

*Program outcome attainment levels shall be set for all relevant PO's and/or PSO's through First year courses.*

*(Describe the assessment processes that demonstrate the degree to which the Program outcomes are attained through First year courses and document the attainment levels. Also include information on assessment processes used to gather the data upon which the evaluation of each Program Outcome is based indicating the frequency with which these processes are carried out)*

Assessment Process used to gather the data upon which the evaluation of each Program Outcome is based

Process to Calculate Attainment of PO's (Annually)

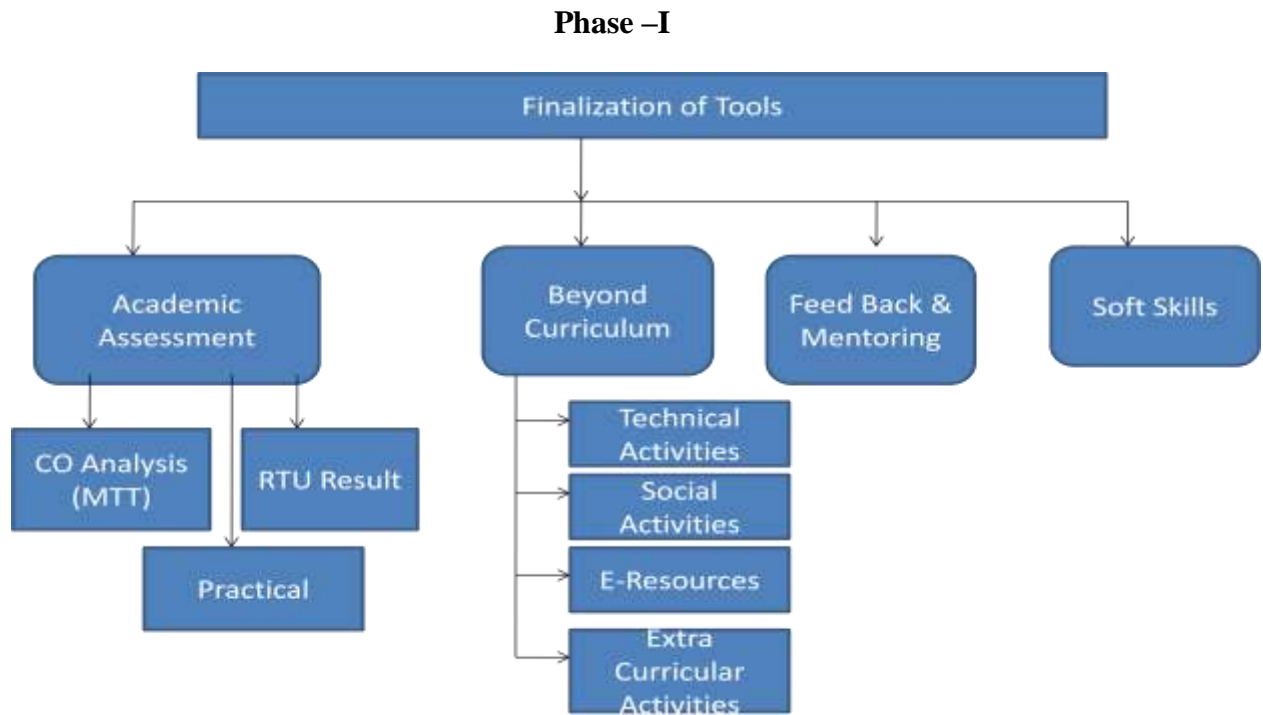

Figure 8.5.1a Process to Calculate Attainment of PO's

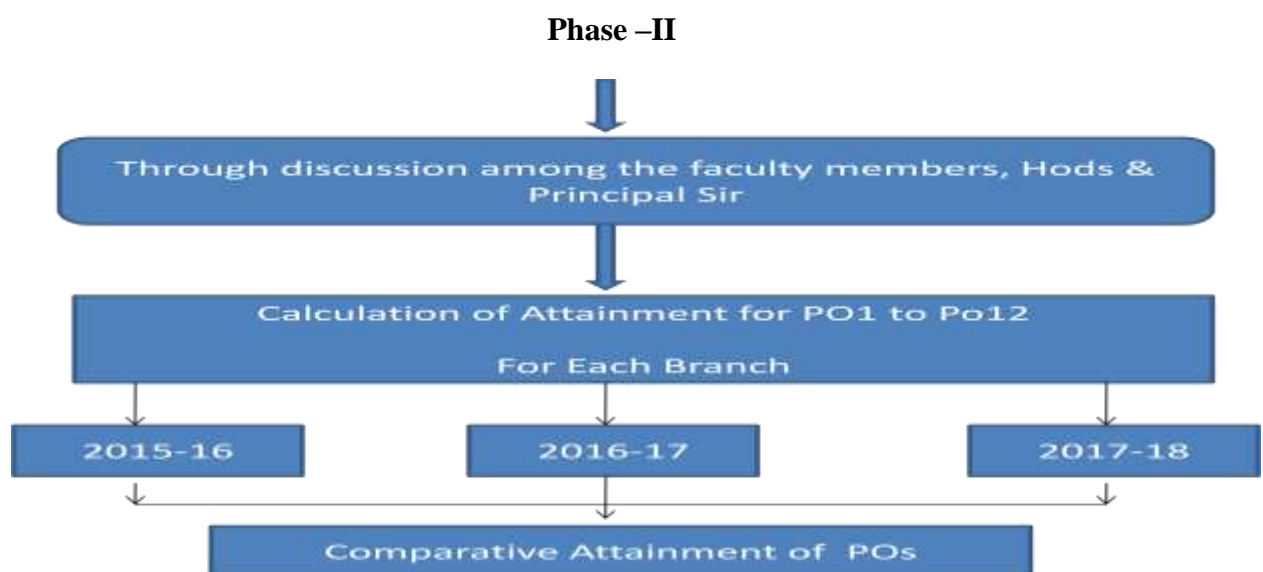

Figure 8.5.1b Process of Finalization of Rubrics

# [SELF ASSESSMENT REPORT]



## Rubrics for PO Attainment

**PO1:** Engineering knowledge: Apply the knowledge of mathematics, science, engineering fundamentals, and an engineering specialization to the solution of complex engineering problems.

Tool	Tools	Mapping	Rubric
Academic Assessment	MTT Result	H	70% students >65%=>100% marks 70% students >60%=>80% 60% students >65%=>60% 60% students >60%=>50% Else =>0 marks
	Final RTU Result	L	70% students >65%=>100% marks 70% students >60%=>80% 60% students >65%=>60% 60% students >60%=>50% Else=> 0 marks
	Lab/Experiments	M	Attendance=> 20% marks Performance =>20% marks Record /File =>10% Internal assessment -1 =>30% External assessment -1 =>20%
Beyond Curriculum	Technical Events	H	>=80% students participated =>100% marks 70-79% students participated=>80% 60-69% students participated=>60% 50-59% students participated=>50% Else=> 0 marks
	Social Events	NA	>=25% students participated =>100% marks 20-24 % students participated =>80% 15-19 % students participated =>60% 10-14 % students participated =>50% Else=> 0 marks
	E-Resources	M	>=50% students =>100% marks 40-49 % students =>80% 30-39 % students =>60% 20-29 % students =>50% Else=> 0 marks



## [SELF ASSESSMENT REPORT]



	Extra Curricular Activity	NA	>=25% students participated =>100% marks 20-24 % students participated =>80% 15-19 % students participated =>60% 10-14 % students participated =>50% Else=> 0 marks
	Mentoring	H	>=100% students mentored => 100% >=90% students mentored=> 90% >=80% students mentored => 80%
			>=70% students studied => 70% Else=>= 0 marks
	Soft Skills	NA	>=80% students retained=> 100% >=70% students retained=> 80% >60% students retained => 70% >=50% students retained=> 60% Else=>= 0 marks

**Table B.8.5.1a Assesment Process for Attaining PO1**

**PO2: Problem analysis:** Identify, formulate, research literature, and analyze complex engineering problems reaching substantiated conclusions using first principles of mathematics, natural sciences, and engineering sciences.

Tool	Tools	Mapping	Rubric
Academic Assessment	MTT Result	M	70% students >65%=>100% marks 70% students >60%=>80% 60% students >65%=>60% 60% students >60%=>50% Else =>0 marks
	Final RTU Result	M	70% students >65%=>100% marks 70% students >60%=>80% 60% students >65%=>60% 60% students >60%=>50% Else=> 0 marks
	Lab/Experiments	M	Attendance=> 20%marks Performance =>20% marks Record /File =>10%

## [SELF ASSESSMENT REPORT]



			Internal assessment -1 =>30% External assessment -1 =>20%
Beyond Curriculum	Technical Events	H	>=80% students participated =>100% marks 70-79% students participated=>80% 60-69% students participated=>60% 50-59% students participated=>50% Else=> 0 marks
	Social Events	NA	>=25% students participated =>100% marks 20-24 % students participated =>80% 15-19 % students participated =>60% 10-14 % students participated =>50% Else=> 0 marks
	E-Resources	M	>=50% students =>100% marks 40-49 % students =>80% 30-39 % students =>60% 20-29 % students =>50% Else=> 0 marks
	Extra Curricular Activity	NA	>=25% students participated =>100% marks 20-24 % students participated =>80% 15-19 % students participated =>60% 10-14 % students participated =>50% Else=> 0 marks
	Mentoring	M	>=100% students mentored => 100% >=90% students mentored=> 90% >=80% students mentored => 80% >=70% students studied => 70% Else=>= 0 marks
	Soft Skills	NA	>=80% students retained=> 100% >=70% students retained=> 80% >60% students retained => 70%

## [SELF ASSESSMENT REPORT]



			>=50% students retained=> 60%  Else=>= 0 marks
--	--	--	--

**Table B.8.5.1b Assessment Process for Attaining PO2**

**PO3: Design/development of solutions:** Design solutions for complex engineering problems and design system components or processes that meet the specified needs with appropriate consideration for the public health and safety, and the cultural, societal, and environmental considerations.

Tool	Tools	Mapping	Rubric
Academic Assessment	MTT Result	M	70% students >65%=>100% marks 70% students >60%=>80% 60% students >65%=>60% 60% students >60%=>50% Else =>0 marks
	Final RTU Result	NA	70% students >65%=>100% marks 70% students >60%=>80% 60% students >65%=>60% 60% students >60%=>50% Else=> 0 marks
	Lab/Experiments	NA	Attendance=> 20%marks Performance =>20% marks Record /File =>10% Internal assessment -1 =>30% External assessment -1 =>20%
Beyond Curriculum	Technical Events	M	>=80% students participated =>100% marks 70-79% students participated=>80%  60-69% students participated=>60%  50-59% students participated=>50%  Else=> 0 marks
	Social Events	H	>=25% students participated =>100% marks 20-24 % students participated =>80%  15-19 % students participated =>60%  10-14 % students participated =>50%  Else=> 0 marks
	E-Resources	L	>=50% students =>100% marks 40-49 % students =>80%

## [SELF ASSESSMENT REPORT]



			30-39 % students =>60% 20-29 % students =>50% Else=> 0 marks
	Extra Curricular Activity	NA	>=25% students participated =>100% marks 20-24 % students participated =>80% 15-19 % students participated =>60% 10-14 % students participated =>50% Else=> 0 marks
	Mentoring	H	>=100% students mentored => 100% >=90% students mentored=> 90% >=80% students mentored => 80% >=70% students studied => 70% Else=>= 0 marks
	Soft Skills	NA	>=80% students retained=> 100% >=70% students retained=> 80% >60% students retained => 70% >=50% students retained=> 60% Else=>= 0 marks

**Table B.8.5.1c Assesment Process for Attaining PO3**

**PO4: Conduct investigations of complex problems:** Use research-based knowledge and research methods including design of experiments, analysis and interpretation of data, and synthesis of the information to provide valid conclusions.

Tool	Tools	Mapping	Rubric
Academic Assessment	MTT Result	NA	70% students >65%=>100% marks 70% students >60%=>80% 60% students >65%=>60% 60% students >60%=>50% Else =>0 marks
	Final RTU Result	NA	70% students >65%=>100% marks 70% students >60%=>80% 60% students >65%=>60% 60% students >60%=>50%

## [SELF ASSESSMENT REPORT]



			Else=> 0 marks
	Lab/Experiments	NA	Attendance=> 20% marks Performance =>20% marks Record /File =>10% Internal assessment -1 =>30% External assessment -1 =>20%
Beyond Curriculum	Technical Events	H	>=80% students participated =>100% marks 70-79% students participated=>80%  60-69% students participated=>60%  50-59% students participated=>50%  Else=> 0 marks
	Social Events	NA	>=25% students participated =>100% marks 20-24 % students participated =>80%  15-19 % students participated =>60%  10-14 % students participated =>50%  Else=> 0 marks
	E-Resources	L (2)	>=50% students =>100% marks 40-49 % students =>80%  30-39 % students =>60%  20-29 % students =>50%  Else=> 0 marks
	Extra Curricular Activity	NA	>=25% students participated =>100% marks 20-24 % students participated =>80%  15-19 % students participated =>60%  10-14 % students participated =>50%  Else=> 0 marks
	Mentoring	H	>=100% students mentored => 100%  >=90% students mentored=> 90%  >=80% students mentored => 80%  >=70% students studied => 70%  Else=>= 0 marks
	Soft Skills	NA	>=80% students retained=> 100%

## [SELF ASSESSMENT REPORT]



			<p><math>\geq 70\%</math> students retained <math>\Rightarrow 80\%</math></p> <p><math>&gt; 60\%</math> students retained <math>\Rightarrow 70\%</math></p> <p><math>\geq 50\%</math> students retained <math>\Rightarrow 60\%</math></p> <p>Else <math>\Rightarrow 0</math> marks</p>
--	--	--	--

**Table B.8.5.1d Assessment Process for Attaining PO4**

**PO5: Modern tool usage:** Create, select, and apply appropriate techniques, resources, and modern engineering and IT tools including prediction and modeling to complex engineering activities with an understanding of the limitations.

Tool	Tools	Mapping	Rubric
Academic Assessment	MTT Result	NA	<p><math>70\%</math> students <math>&gt; 65\% \Rightarrow 100\%</math> marks</p> <p><math>70\%</math> students <math>&gt; 60\% \Rightarrow 80\%</math></p> <p><math>60\%</math> students <math>&gt; 65\% \Rightarrow 60\%</math></p> <p><math>60\%</math> students <math>&gt; 60\% \Rightarrow 50\%</math></p> <p>Else <math>\Rightarrow 0</math> marks</p>
	Final RTU Result	NA	<p><math>70\%</math> students <math>&gt; 65\% \Rightarrow 100\%</math> marks</p> <p><math>70\%</math> students <math>&gt; 60\% \Rightarrow 80\%</math></p> <p><math>60\%</math> students <math>&gt; 65\% \Rightarrow 60\%</math></p> <p><math>60\%</math> students <math>&gt; 60\% \Rightarrow 50\%</math></p> <p>Else <math>\Rightarrow 0</math> marks</p>
	Lab/Experiments	NA	<p>Attendance <math>\Rightarrow 20\%</math> marks</p> <p>Performance <math>\Rightarrow 20\%</math> marks</p> <p>Record /File <math>\Rightarrow 10\%</math></p> <p>Internal assessment -1 <math>\Rightarrow 30\%</math></p> <p>External assessment -1 <math>\Rightarrow 20\%</math></p>
Beyond Curriculum	Technical Events	H	<p><math>\geq 80\%</math> students participated <math>\Rightarrow 100\%</math> marks</p> <p><math>70-79\%</math> students participated <math>\Rightarrow 80\%</math></p> <p><math>60-69\%</math> students participated <math>\Rightarrow 60\%</math></p> <p><math>50-59\%</math> students participated <math>\Rightarrow 50\%</math></p> <p>Else <math>\Rightarrow 0</math> marks</p>
	Social Events	NA	<p><math>\geq 25\%</math> students participated <math>\Rightarrow 100\%</math> marks</p> <p><math>20-24\%</math> students participated <math>\Rightarrow 80\%</math></p> <p><math>15-19\%</math> students participated <math>\Rightarrow 60\%</math></p> <p><math>10-14\%</math> students participated <math>\Rightarrow 50\%</math></p> <p>Else <math>\Rightarrow 0</math> marks</p>
	E-Resources	L	$\geq 50\%$ students $\Rightarrow 100\%$ marks

## [SELF ASSESSMENT REPORT]



			40-49 % students =>80% 30-39 % students =>60% 20-29 % students =>50% Else=> 0 marks
	Extra Curricular Activity	NA	>=25% students participated =>100% marks 20-24 % students participated =>80% 15-19 % students participated =>60% 10-14 % students participated =>50% Else=> 0 marks
10%	Mentoring	H	>=100% students mentored => 100% >=90% students mentored=> 90% >=80% students mentored => 80% >=70% students studied => 70% Else=>= 0 marks
	Soft Skills	NA	>=80% students retained=> 100% >=70% students retained=> 80% >60% students retained => 70% >=50% students retained=> 60% Else=>= 0 marks

**Table B.8.5.1e Assesment Process for Attaining PO5**

**PO6: The engineer and society:** Apply reasoning informed by the contextual knowledge to assess societal, health, safety, legal and cultural issues and the consequent responsibilities relevant to the professional engineering practice.

Tool	Tools	Mapping	Rubric
Academic Assessment	MTT Result	NA	70% students >65%=>100% marks 70% students >60%=>80% 60% students >65%=>60% 60% students >60%=>50% Else =>0 marks
	Final RTU Result	NA	70% students >65%=>100% marks 70% students >60%=>80%

## [SELF ASSESSMENT REPORT]



			60% students >65% =>60% 60% students >60% =>50% Else => 0 marks
	Lab/Experiments	NA	Attendance => 20% marks Performance => 20% marks Record /File => 10% Internal assessment -1 => 30% External assessment -1 => 20%
Beyond Curriculum	Technical Events	NA	>=80% students participated =>100% marks 70-79% students participated =>80%  60-69% students participated =>60%  50-59% students participated =>50%  Else => 0 marks
	Social Events	H	>=25% students participated =>100% marks 20-24 % students participated =>80%  15-19 % students participated =>60%  10-14 % students participated =>50%  Else => 0 marks
	E-Resources	L	>=50% students =>100% marks 40-49 % students =>80%  30-39 % students =>60%  20-29 % students =>50%  Else => 0 marks
	Extra Curricular Activity	L	>=25% students participated =>100% marks 20-24 % students participated =>80%  15-19 % students participated =>60%  10-14 % students participated =>50%  Else => 0 marks
	Mentoring	H	>=100% students mentored => 100%  >=90% students mentored => 90%  >=80% students mentored => 80%  >=70% students studied => 70%



## [SELF ASSESSMENT REPORT]



			Else=>= 0 marks
	Soft Skills	NA	>=80% students retained=> 100% >=70% students retained=> 80% >60% students retained => 70% >=50% students retained=> 60% Else=>= 0 marks

**Table B.8.5.1f Assesment Process for Attaining PO6**

**PO7: Environment and sustainability:** Understand the impact of the professional engineering solutions in societal and environmental contexts, and demonstrate the knowledge of, and need for sustainable development.

Tool	Tools	Mapping	Rubric
Academic Assessment	MTT Result	M	70% students >65%=>100% marks 70% students >60%=>80% 60% students >65%=>60% 60% students >60%=>50% Else =>0 marks
	Final RTU Result	L	70% students >65%=>100% marks 70% students >60%=>80% 60% students >65%=>60% 60% students >60%=>50% Else=> 0 marks
	Lab/Experiments	NA	Attendance=> 20%marks Performance =>20% marks Record /File =>10% Internal assessment -1 =>30% External assessment -1 =>20%
Beyond Curriculum	Technical Events	L	>=80% students participated =>100% marks 70-79% students participated=>80%  60-69% students participated=>60%  50-59% students participated=>50%  Else=> 0 marks
	Social Events	H	>=25% students participated =>100% marks 20-24 % students participated =>80%

## [SELF ASSESSMENT REPORT]



			15-19 % students participated =>60% 10-14 % students participated =>50% Else=> 0 marks
	E-Resources	L	>=50% students =>100% marks 40-49 % students =>80% 30-39 % students =>60% 20-29 % students =>50% Else=> 0 marks
	Extra Curricular Activity	NA	>=25% students participated =>100% marks 20-24 % students participated =>80% 15-19 % students participated =>60% 10-14 % students participated =>50% Else=> 0 marks
	Mentoring	H	>=100% students mentored => 100% >=90% students mentored=> 90% >=80% students mentored => 80% >=70% students studied => 70% Else=>= 0 marks
	Soft Skills	NA	>=80% students retained=> 100% >=70% students retained=> 80% >60% students retained => 70% >=50% students retained=> 60% Else=>= 0 marks

**Table B.8.5.1g Assesment Process for Attaining PO7**

## [SELF ASSESSMENT REPORT]



**PO8: Ethics:** Apply ethical principles and commit to professional ethics and responsibilities and norms of the engineering practice.

Tool	Tools	Weightage	Mapping	Rubric
Academic Assessment	MTT Result	NA	NA	70% students >65%=>100% marks 70% students >60%=>80% 60% students >65%=>60% 60% students >60%=>50% Else =>0 marks
	Final RTU Result	NA	NA	70% students >65%=>100% marks 70% students >60%=>80% 60% students >65%=>60% 60% students >60%=>50% Else=> 0 marks
	Lab/Experiments	NA	NA	Attendance=> 20%marks Performance =>20% marks Record /File =>10% Internal assessment -1 =>30% External assessment -1 =>20%
Beyond Curriculum	Technical Events	NA	NA	>=80% students participated =>100% marks 70-79% students participated=>80%  60-69% students participated=>60%  50-59% students participated=>50%  Else=> 0 marks
	Social Events	NA	NA	>=25% students participated =>100% marks 20-24 % students participated =>80%  15-19 % students participated =>60%  10-14 % students participated =>50%  Else=> 0 marks
	E-Resources	NA	NA	>=50% students =>100% marks 40-49 % students =>80%  30-39 % students =>60%  20-29 % students =>50%  Else=> 0 marks
	Extra Curricular Activity	NA	NA	>=25% students participated =>100% marks 20-24 % students participated =>80%

## [SELF ASSESSMENT REPORT]



				15-19 % students participated =>60% 10-14 % students participated =>50% Else=> 0 marks
	Mentoring	NA	NA	>=100% students mentored => 100% >=90% students mentored=> 90% >=80% students mentored => 80% >=70% students studied => 70% Else=>= 0 marks
	Soft Skills	NA	NA	>=80% students retained=> 100% >=70% students retained=> 80% >60% students retained => 70% >=50% students retained=> 60% Else=>= 0 marks

**Table B.8.5.1h Assesment Process for Attaining PO8**

**PO9: Individual and team work:** Function effectively as an individual, and as a member or leader in diverse teams, and in multidisciplinary settings.

Tool	Tools	Mapping	Rubric
Academic Assessment	MTT Result	NA	70% students >65%=>100% marks 70% students >60%=>80% 60% students >65%=>60% 60% students >60%=>50% Else =>0 marks
	Final RTU Result	NA	70% students >65%=>100% marks 70% students >60%=>80% 60% students >65%=>60% 60% students >60%=>50% Else=> 0 marks
	Lab/Experiments	NA	Attendance=> 20% marks Performance =>20% marks Record /File =>10% Internal assessment -1 =>30% External assessment -1 =>20%

## [SELF ASSESSMENT REPORT]



Beyond Curriculum	Technical Events	L	>=80% students participated =>100% marks 70-79% students participated=>80%  60-69% students participated=>60%  50-59% students participated=>50%  Else=> 0 marks
	Social Events	H	>=25% students participated =>100% marks 20-24 % students participated =>80%  15-19 % students participated =>60%  10-14 % students participated =>50%  Else=> 0 marks
	E-Resources	NA	>=50% students =>100% marks 40-49 % students =>80%  30-39 % students =>60%  20-29 % students =>50%  Else=> 0 marks
	Extra Curricular Activity	H	>=25% students participated =>100% marks 20-24 % students participated =>80%  15-19 % students participated =>60%  10-14 % students participated =>50%  Else=> 0 marks
	Mentoring	L	>=100% students mentored => 100%  >=90% students mentored=> 90%  >=80% students mentored => 80%  >=70% students studied => 70%  Else=>= 0 marks
	Soft Skills	NA	>=80% students retained=> 100%  >=70% students retained=> 80%  >60% students retained => 70%  >=50% students retained=> 60%

## [SELF ASSESSMENT REPORT]



			Else=>= 0 marks
--	--	--	-----------------

**Table B.8.5.1i Assesment Process for Attaining PO9**

**PO10: Communication:** Communicate effectively on complex engineering activities with the engineering community and with society at large, such as, being able to comprehend and write effective reports and design documentation, make effective presentations, and give and receive clear instructions.

Tool	Tools	Mapping	Rubric
Academic Assessment	MTT Result	L	70% students >65%=>100% marks 70% students >60%=>80% 60% students >65%=>60% 60% students >60%=>50% Else =>0 marks
	Final RTU Result	L	70% students >65%=>100% marks 70% students >60%=>80% 60% students >65%=>60% 60% students >60%=>50% Else=> 0 marks
	Lab/Experiments	NA	Attendance=> 20% marks Performance =>20% marks Record /File =>10% Internal assessment -1 =>30% External assessment -1 =>20%
Beyond Curriculum	Technical Events	M	>=80% students participated =>100% marks 70-79% students participated=>80%  60-69% students participated=>60%  50-59% students participated=>50%  Else=> 0 marks
	Social Events	L	>=25% students participated =>100% marks 20-24 % students participated =>80%  15-19 % students participated =>60%  10-14 % students participated =>50%

## [SELF ASSESSMENT REPORT]



			Else=> 0 marks
	E-Resources	L	>=50% students =>100% marks 40-49 % students =>80%  30-39 % students =>60%  20-29 % students =>50%  Else=> 0 marks
	Extra Curricular Activity	L	>=25% students participated =>100% marks 20-24 % students participated =>80%  15-19 % students participated =>60%  10-14 % students participated =>50%  Else=> 0 marks
	Mentoring	L	>=100% students mentored => 100%  >=90% students mentored=> 90%  >=80% students mentored => 80%  >=70% students studied => 70%  Else=>= 0 marks
	Soft Skills	NA	>=80% students retained=> 100%  >=70% students retained=> 80%  >60% students retained => 70%  >=50% students retained=> 60%  Else=>= 0 marks

**Table B.8.5.1j Assesment Process for Attaining PO10**

**PO11: Project management and finance:** Demonstrate knowledge and understanding of the engineering and management principles and apply these to one's own work, as a member and leader in a team, to manage projects and in multidisciplinary environments.

## [SELF ASSESSMENT REPORT]



Tool	Tools	Mapping	Rubric
Academic Assessment	MTT Result	NA	70% students >65%=>100% marks 70% students >60%=>80% 60% students >65%=>60% 60% students >60%=>50% Else =>0 marks
	Final RTU Result	NA	70% students >65%=>100% marks 70% students >60%=>80% 60% students >65%=>60% 60% students >60%=>50% Else=> 0 marks
	Lab/Experiments	NA	Attendance=> 20%marks Performance =>20% marks Record /File =>10% Internal assessment -1 =>30% External assessment -1 =>20%
Beyond Curriculum	Technical Events	NA	>=80% students participated =>100% marks 70-79% students participated=>80% 60-69% students participated=>60% 50-59% students participated=>50% Else=> 0 marks
	Social Events	NA	>=25% students participated =>100% marks 20-24 % students participated =>80% 15-19 % students participated =>60% 10-14 % students participated =>50% Else=> 0 marks
	E-Resources	NA	>=50% students =>100% marks 40-49 % students =>80% 30-39 % students =>60% 20-29 % students =>50% Else=> 0 marks
	Extra Curricular Activity	NA	>=25% students participated =>100% marks 20-24 % students participated



## [SELF ASSESSMENT REPORT]



			<p>=&gt;80%</p> <p>15-19 % students participated =&gt;60%</p> <p>10-14 % students participated =&gt;50%</p> <p>Else=&gt; 0 marks</p>
Placement	Mentoring	NA	<p>&gt;=100% students mentored =&gt; 100%</p> <p>&gt;=90% students mentored=&gt; 90%</p> <p>&gt;=80% students mentored =&gt; 80%</p> <p>&gt;=70% students studied =&gt; 70%</p> <p>Else=&gt;= 0 marks</p>
	Soft Skills	NA	<p>&gt;=80% students retained=&gt; 100%</p> <p>&gt;=70% students retained=&gt; 80%</p> <p>&gt;60% students retained =&gt; 70%</p> <p>&gt;=50% students retained=&gt; 60%</p> <p>Else=&gt;= 0 marks</p>

**Table B.8.5.1k Assesment Process for Attaining PO11**

**PO12:Life-long learning:** Recognize the need for, and have the preparation and ability to engage in independent and life-long learning in the broadest context of technological change.

Tool	Tools	Mappin g	Rubric
Academic Assessment	MTT Result	L	<p>70% students &gt;65%=&gt;100% marks</p> <p>70% students &gt;60%=&gt;80%</p> <p>60% students &gt;65%=&gt;60%</p> <p>60% students &gt;60%=&gt;50%</p> <p>Else =&gt;0 marks</p>
	Final RTU Result	L	<p>70% students &gt;65%=&gt;100% marks</p> <p>70% students &gt;60%=&gt;80%</p> <p>60% students &gt;65%=&gt;60%</p> <p>60% students &gt;60%=&gt;50%</p> <p>Else=&gt; 0 marks</p>

## [SELF ASSESSMENT REPORT]



	Lab/Experiments	NA	Attendance=> 20% marks Performance =>20% marks Record /File =>10% Internal assessment -1 =>30% External assessment -1 =>20%
Beyond Curriculum	Technical Events	L	>=80% students participated =>100% marks 70-79% students participated=>80% 60-69% students participated=>60% 50-59% students participated=>50% Else=> 0 marks
	Social Events	L	>=25% students participated =>100% marks 20-24 % students participated =>80% 15-19 % students participated =>60% 10-14 % students participated =>50% Else=> 0 marks
	E-Resources	L	>=50% students =>100% marks 40-49 % students =>80% 30-39 % students =>60% 20-29 % students =>50% Else=> 0 marks
	Extra Curricular Activity	L	>=25% students participated =>100% marks 20-24 % students participated =>80% 15-19 % students participated =>60% 10-14 % students participated =>50% Else=> 0 marks
Placement	Mentoring	L	>=100% students mentored => 100% >=90% students mentored=> 90% >=80% students mentored => 80% >=70% students studied => 70%

## [SELF ASSESSMENT REPORT]



			Else=>= 0 marks
	Soft Skills	L	>=80% students retained=> 100% >=70% students retained=> 80% >60% students retained => 70% >=50% students retained=> 60% Else=>= 0 marks

**Table B.8.5.11 Assesment Process for Attaining PO12**

**PO Attainment Levels through First Year courses:**

**Session: 2018-19**

**Semeter I**

Course Code	Course	PO 1	PO 2	PO 3	PO 4	PO 5	PO 6	PO 7	PO 8	PO 9	PO 10	PO 11	PO 12
CO1 01	Engineering Mathematics -I	3	1	-	-	-	-	-	-	1	1	-	1
CO1 02	Engineering Physics	2	1	-	-	-	0.25	-	-	1	0.25	-	1
CO1 02	Engineering Chemistry	2	1	0.75	0.5	-	0.75	0.75	-	-	0.75	-	-
CO1 03	Communication Skills	-	-	2	-	-	3	2	3	2	1	-	1
CO1 04	Programming for Problem Solving	1.5	1.75	1.75	1.75	1.25	0.5	0.75	NA	0.25	1.25	NA	1.5
CO1 05	Basic Electrical Engineering	2.66	2.33	1	1.33	1.33	-	-	-	2	0.33	-	-
CO1	Engineering	2	1	1	-	-	0.5	-	-	1	1	-	2

## [SELF ASSESSMENT REPORT]



06	Physics Lab												
CO1 06	Engineering Chemistry Lab	1.6 6	1.6 6	-	1	-	-	0.6 6	-	1	2	-	-
CO1 07	Language Lab	-	1	-	-	-	1	-	-	3	3	-	1
CO1 08	Computer Programmin g Lab	1.6 7	1.3 3	1.6 7	0.3 3	0.6 7	1	NA	N A	1	0.6 7	NA	0. 67

**Table B.8.5.1(a) PO Attainment of Sem. I (2017-18)**

**Session: 2017-18**

**Semeter I**

Course Code	Course	PO1	PO 2	PO3	PO 4	PO 5	PO 6	PO7	PO 8	PO 9	PO 10	PO 11	PO 12
MA-101	Engineering Mathematics-1	3	2	1	-	1.25	1	2	-	3	2	-	1
HU-103	Human Values	-	-	2	-	-	3	2	3	2	1	-	1
PY-101	Engineering Physics	2	1	1	-	-	1	-	-	1	1	-	1
CS-101	Computer Programming-I	2.75	1.75	1.50	1.75	1.5	1.25	1	-	-	1.25	-	2.5
CE-101	Environmental Engineering and Disaster Management	2	0.75	1	0.5	-	1.75	1.75	1	.75	.5	-	1
HU-104	Human Values: Activities	-	-	1	-	-	3	3	3	1	1	-	1
PY-102	Engineering Physics Lab	2	1	1	-	-	1	-	-	1	1	-	1
CS-102	Computer Programming-I Lab	2	3	2	1	-	-	-	-	2	1	-	1
CE-102	Computer Aided Engineering	3	-	-	-	-	-	-	-	2	2	-	1

## [SELF ASSESSMENT REPORT]



	Graphic												
ME-101	Mechanical Workshop Practice	3	-	-	-	-	-	-	-	2	2	-	1
	Average Attainment	2.46	1.58	1.21	1.08	1.37	1.71	1.95	2.33	1.63	1.27	-	1.15

**Table B.8.5.1(b) PO Attainment of Sem. I (2017-18)**

**Session: 2017-18**

### SEM II

Course Code	Course	PO 1	PO 2	PO 3	PO 4	PO 5	PO 6	PO 7	PO 8	PO 9	PO 10	PO 11	PO 12
MA-102	Engineering Mathematics-II	3	2	1	-	1.25	1	2	-	3	2	-	1
HU-101	Communication Skills	-	1	2	-	-	1	-	-	3	3	-	1
CY-101	Engineering Chemistry	2	1	0.5	0.5	-	0.25	0.5	-	-	0.5	-	-
CS-103	computer Programming-II	2.25	1.75	1.5	2.25	2	1.75	2	--	-	2	-	1.75
CE-103	BASic Civil Engineering	1.5	1	.5	-	-	.25	.5	.25	.75	.25	.5	.25
ME-102	Basic Mechanical Engineering	2.25	-	.75	2.25	.75	.25	1.5	2.25	.5	1.25	-	1

## [SELF ASSESSMENT REPORT]



CY-102	Engineering Chemistry Lab	2	2	-	1	-	-	-	-	1	2	-	-
CS-104	Computer Programming-II	2	2	3	1	-	--	-	-	2	1	2	1
HU-102	Communication Skills Lab	-	1	-	-	-	1	-	-	3	3	-	1
ME-104	Computer Aided Machine Drawing	3	2	2	-	2	2	2	-	-	2	-	2
	Average Attainment	2.25	1.52	1.40	1.40	1.50	0.93	1.41	1.25	1.89	1.70	1.25	1.12

**Table B.8.5.1(c) PO Attainment of Sem. II (2017-18)**

**Session: 2016-2017(I Semester)**

Course Code	Course	PO1	PO2	PO3	PO 4	PO 5	PO 6	PO7	PO 8	PO 9	PO 10	PO 11	PO 12
101	Communicative English	-	1	1	-	-	-	1.3	-	-	3	-	1
102	Engg. Maths-I	3	3	1.6	1	1	1	1	-	2	2	-	1
103	Engg. Physics-I	3	3	1	.75	1.5	2.5	1.75	-	2	1.25	1	1.5
104	Engg. Chemistry	2	1.3	1	1	-	2	2	-	-	1	-	1
105	Basic EE	2.8	2.6	2	2	1.4	1.2	1.2	-	1.8	1	1.4	2.2
106	Physics Lab	3	3	2.5	1	2.5	3	2.5	2	2.5	1	1	2
107	Chemistry lab	2	1.67	1.67	1	-	2	2	-	1	1	-	1

## [SELF ASSESSMENT REPORT]



108	EE Lab	2.8	2.9	1.4	-	-	2	-	-	0.33	-	-	3
110	Workshop	3	1.5	1	0.5	-	1	0.5	-	1	0.5	0.5	1.5
	Average Attainment	2.7	2.21	1.46	1.03	1.6	1.83	1.53	2	1.51	1.34	0.97	1.57

**Table B.8.5.1(d) PO Attainment of Sem.I (2015-16,2016-17,2017-18)**

# [SELF ASSESSMENT REPORT]



**Session: 2016-2017(II Semester)**

Course Code	Course	PO1	PO2	PO3	PO 4	PO 5	PO 6	PO 7	PO 8	PO 9	PO 10	PO 11	PO 12
201	Communication Techniques	-	1	2	-	-	1	-	1	3	3	-	1
202	Engg. Maths-II	3	2	1	-	1.25	1	2	-	3	2	-	1
203	Engg. Physics-II	3	3	2	1	1.8	2.2	2	-	1.6	1.4	1	2
204	Chemistry & Env. Engg.	2	1.33	1	-	-	-	2	-	-	1	-	1
205	Engg. Mechanics	3	2	-	-	-	-	-	-	-	-	-	2
206	FOC	2.75	1.5	1.5	1.25	1.25	1	1.25	-	1.75	1.25	-	1.25
207	Physics Lab-II	3	3	2.5	2	3	3	1.5	1.5	2.5	2	1	2
208	Chemistry lab	2	1	1	1	-	1	2	-	1	1	-	1
209	CP Lab	2.7	1.5	1	1.2	1.2	1	1.2	-	1.7	1.2	-	1.2
210	Machine Drawing	3	2	2	-	2	2	2	-	-	2	-	2
211	CT Lab	-	-	1	-	-	1	-	1	3	3	-	1
	Average Attainment	2.71	1.83	1.5	1.29	1.75	1.46	1.74	1.16	2.19	1.78	1	1.4

**Table B.8.5.1(e) PO Attainment of Sem.I (2015-16,2016-17,2017-18)**

## 8.5.2. Actions taken based on the results of evaluation of relevant POs (5)

*(The attainment levels by direct (student performance) are to be presented through Program level Course-PO matrix as indicated)*

### **PO Attainment Levels and Actions for improvement – CAYp1 only – Mention for relevant POs**

- **2018 -19 session going on (Results awaited)**



# [SELF ASSESSMENT REPORT]



**PO Attainment Levels and Actions for improvement – CAY only – Mention for relevant POs**

**Session: 2017-2018**

POs	Target Level in %	Attainment Level in %	Observations
<b>PO1: Engineering knowledge:</b>			
PO1	58.05	46.93	Observations: <ul style="list-style-type: none"><li>• Targets are not fully achieved in RTU results.</li><li>• Students are not exposed to complex engineering problems.</li></ul>
Action 1: More technical activities were conducted to improve the participation of students.			
Action 2: University question papers are solved in classes.			
<b>PO2: Problem analysis:</b>			
PO2	67.38	55.61	Observations : <ul style="list-style-type: none"><li>• Students are not exposed to complex engineering problems</li><li>• Curriculum designed for I Year does not contain literature research and analysis of problem</li></ul>
Action 1: Students are motivated to participate in science project exhibition for developing an analytical mind which can work towards problem solving.			
Action 2: Students are motivated for optimum utilization of E-Resources to enhance their knowledge.			
<b>PO3: Design/development of solutions:</b>			
PO3	67.79	62.75	Observations : <ul style="list-style-type: none"><li>• I Year curriculum include only basic knowledge of Engineering and sciences.</li></ul>
Action 1: More activities involving designing solutions like Hackathon are initiated in the campus.			

## [SELF ASSESSMENT REPORT]



Action 2: Students are motivated to improve their participation in technical/social/extra-curricular activities.

### **PO4: Conduct investigations of complex problems:**

PO4:	51.58	46.91	Observations : <ul style="list-style-type: none"><li>• Few activities related to understanding of complex problems and its investigation.</li></ul>
------	-------	-------	---

Action 1: Workshops are conducted to give the hands on experience to students and faculty member.

Action 2: They are motivated to use E- Resources and register themselves in online courses.

### **PO5: Modern tool usage:**

PO5	55.54	50.31	Observations : <ul style="list-style-type: none"><li>• Target and attainment both are less as students learn basics of computer programming in I Year.</li><li>• Other subjects does not use modern IT tools for problem solving.</li></ul>
-----	-------	-------	---

Action 1: Technical events are organized at institute level so that students can participate and learn latest techniques and methods of problem solving.

Action 2: Students are motivated to participate in inter college events to get exposure to real world problems.

### **PO6: The engineer and society:**

PO6	61.8	56.33	Observations : <ul style="list-style-type: none"><li>• The students are found to be less active as far as social activities were concerned; also they were unaware about the basic health and safety issues with engineering point of view.</li><li>• Most of the courses of B.Tech first year are not addressing the needs of, health, safety and social concerns regarding engineering practices in real life.</li></ul>
-----	------	-------	--

Action 1: The students are motivated to be a part of social groups like Soch, Suhasini,

## [SELF ASSESSMENT REPORT]



Aashayein, Zarurat available at Institute.

Action 2: These groups encouraged students to take part in Swachh Bharat drives, Blood Donation Camps, Village visits, voluntary teaching and mentoring of downtrodden children.

### **PO7: Environment and sustainability:**

PO7	54.66	48.79	Observations : <ul style="list-style-type: none"><li>• Less awareness of students about the issues related to global and environmental sustainability.</li></ul>
-----	-------	-------	--

Action 1: Students are encouraged to indulge in projects in which global and environmental issues are improved.

Action 2: The activities like Tree Plantation Drive and Cleanliness Drive are organized to instill in them the responsibility towards environment.

Action 3: The students were mentored to practice rain water harvesting, water conservation and waste recycling at the individual level.

### **PO8: Ethics:**

PO8	14.27	10.99	Observations: <ul style="list-style-type: none"><li>• The students were reluctant to bear upon a responsibility in the competitive activities. Moreover, some of the students were found to be casual in their conduct.</li></ul>
-----	-------	-------	---

Action 1: As far as professional conduct and behavior is concerned the students are made to attend anti- ragging seminars, interactive talks on personal conduct and behavior with eminent advisors in the college.

Action 2: The college has a well- established spiritual cell which encourages students to experience professional life with high moral conduct and spirituality.

### **PO9: Individual and team work:**

PO9	69	63.07	Observations: <ul style="list-style-type: none"><li>• Classroom teaching does not provide environment for team work, whereas student can show his/her working as a team member or team leader during</li></ul>
-----	----	-------	--

## [SELF ASSESSMENT REPORT]



			practical classes and other co curricular activities.
<p>Action 1: The students are mentored and encouraged by the faculty member to participate in group activities and lead the group as a responsible leader. The group activities included Hackathon, Fun activities at college fest, Model United Nations etc.</p> <p>Action 2: The activities like Group discussions, quizzes etc., technical events like J- Techtrix, JECRC Hackathon etc. and volunteering and coordinating for various events in annual fest Renaissance.</p>			
<b>PO10: Communication:</b>			
PO10	49.94	40.27	<p>Observations:</p> <ul style="list-style-type: none"> <li>The students are found to be hesitant in public speaking and express their opinion.</li> </ul>
<p>Action 1: In order to address this issue, the group of students are asked to prepare and give power point presentations on the topics within the curriculum as well as the beyond the curriculum.</p> <p>Action 2: They are encouraged to participate in house and inter-college competitions to enhance their communication skills.</p>			
<b>PO11: Project management and finance:</b>			
PO11	NA	NA	<p>Observations:</p> <ul style="list-style-type: none"> <li>I Year students are not involved in project management and finance, but they can learn the basics by participating in other activities organized in college.</li> </ul>
<p>Action 1: Annual Project exhibition is organized in the college where I year students participate learn the basics of project handling and finance.</p>			
<b>PO12: Life-long learning:</b>			
PO12	33.05	25.18	<p>Observations :</p> <ul style="list-style-type: none"> <li>The students are ignorant about the significance of the subject in broader</li> </ul>

## [SELF ASSESSMENT REPORT]



			context of life.
<p>Action 1: Lecture content includes applications and advances in subject knowledge of new techniques.</p> <p>Action 2: Students are mentored to work for better achievement forever.</p> <p>Action 3: Students are motivated to improve their participation in technical/social/extra-curricular activities.</p>			

**Table B.8.5.2a PO Attainment Levels and Actions for improvement for 2017-18**

**Attainment of PO's From I Year Courses in the year  
Session: 2017-18**

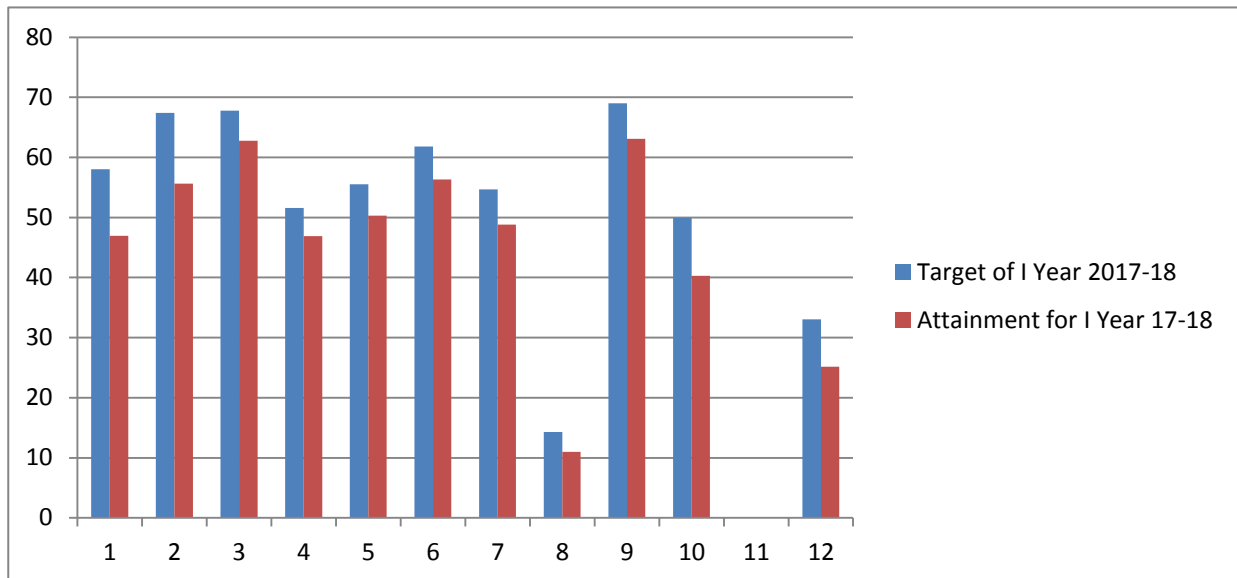

**Figure 8.5.2a Attainment of PO's From I Year Courses in the year 2017-18**

**PO Attainment Levels and Actions for improvement – CAYm1 only – Mention for relevant POs**

**Session: 2016-2017**

POs	Target Level in %	Attainment Level in %	Observations
<b>PO1: Engineering knowledge:</b>			
PO1	62.53	53.64	Observations: <ul style="list-style-type: none"> <li>Participation in technical events can be improved.</li> <li>In RTU result, students are attaining less marks.</li> </ul>

## [SELF ASSESSMENT REPORT]



Action 1: RTU question papers were solved discussed in regular classes to improve the RTU result.

Action 2: Extra classes based on university question paper & pattern was taken.

Action 3: more technical activities were conducted to improve the participation of students.

### **PO2: Problem analysis:**

PO2	70.03	50.03	Observations : <ul style="list-style-type: none"><li>• Curriculum designed for I Year does not contain literature research and analysis of problem</li><li>• Use of e- resources was less so it can be improved.</li></ul>
-----	-------	-------	--

Action 1: Department took the initiative to organize National/International conferences.

Action 2: Students are motivated to participate in science project exhibition for developing an analytical mind which can work towards problem solving.

Action 3: Students are guided to use more & more e-resources.

### **PO3:Design/development of solutions:**

PO3	67.18	55.46	Observations : <ul style="list-style-type: none"><li>• I Year curriculum include basic knowledge of Engineering and sciences.</li><li>• Participation in technical &amp; social activities was less.</li></ul>
-----	-------	-------	--

Action 1: Students were motivated to improve their participation in technical/social/extra-curricular activities.

Action 2: Students are motivated to join various Technical Clubs in Institute.

### **PO4: Conduct investigations of complex problems:**

PO4:	42.65	38.1	Observations : <ul style="list-style-type: none"><li>• Participation in technical activities was less.</li><li>• Use of e- resources was less .</li><li>• Students have less understanding of complex problems and its investigation.</li></ul>
------	-------	------	---

## [SELF ASSESSMENT REPORT]



Action 1: Participation in technical activities was increased by mentoring & motivation.

Action 2: Workshops are conducted to give the hands on experience to students and faculty member.

Action 2: They are motivated to use E- Resources and register themselves in online courses.

### **PO5: Modern tool usage:**

PO5	44.44	38.8	Observations : <ul style="list-style-type: none"><li>• Target and attainment both are less as students learn basics of computer programming in I Year.</li><li>• Other subjects does not use modern it tools for problem solving.</li></ul>
-----	-------	------	---

Action 1: More of technical events are organized at institute level.

Action 2: Students are motivated to join robotics/moon rider etc.

### **PO6: The engineer and society:**

PO6	61.2	51.04	Observations : <ul style="list-style-type: none"><li>• Students need to be made more sensitive towards social issues.</li></ul>
-----	------	-------	---

Action 1: The students are encouraged to join social groups like Soch, Suhasini, Aashayein, Zarurat etc.

### **PO7: Environment and sustainability:**

PO7	48.88	39.49	Observations : <ul style="list-style-type: none"><li>• Less awareness of students about the issues related to global and environmental sustainability.</li></ul>
-----	-------	-------	--

Action 1: Students are encouraged to indulge in projects in which global and environmental issues are improved.

Action 2: The activities related to environment and sustainability are organized.

### **PO8: Ethics:**

PO8	8.14	7.61	Observations:
-----	------	------	---------------

## [SELF ASSESSMENT REPORT]



			<ul style="list-style-type: none"> <li>The students were reluctant to bear upon a responsibility in the competitive activities. Moreover, some of the students were found to be casual in their conduct.</li> </ul>
<p>Action 1: As far as professional conduct and behavior is concerned the students were made to attend anti- ragging seminars, interactive talks on personal conduct and behavior with eminent advisors in the college.</p> <p>Action 2: The college has a well- established spiritual cell which encourages students to experience professional life with high moral conduct and spirituality.</p>			
<b>PO9: Individual and team work:</b>			
PO9	71.85	62.4	<p>Observations:</p> <ul style="list-style-type: none"> <li>Team activities should be included in regular practice.</li> </ul>
<p>Action 2: The team activities like Group discussions, quizzes etc., technical events like J-Techtrix, and volunteering and coordinating for various events in annual fest Renaissance, MUN.</p>			
<b>PO10: Communication:</b>			
PO10	52.4	40.19	<p>Observations:</p> <ul style="list-style-type: none"> <li>The students are unable to express their views on public platform.</li> </ul>
<p>Action 1: In order to address this issue, the group of students are asked to prepare and give power point presentations on the topics within the curriculum as well as the beyond the curriculum.</p> <p>Action 2: They are encouraged to participate various competitions to enhance their communication skills.</p>			
<b>PO11: Project management and finance:</b>			
PO11	NA	NA	<p>Observations:</p> <ul style="list-style-type: none"> <li>I Year students are not involved in project management and finance, but they can learn the basics by participating in other activities</li> </ul>



## [SELF ASSESSMENT REPORT]



			organized in college.
Action 1: Annual Project exhibition is organized in the college where I year students participate learn the basics of project handling and finance.			
<b>PO12: Life-long learning:</b>			
PO12	36.08	32.05	Observations : <ul style="list-style-type: none"> <li>The students were ignorant about the significance of the subject in broader context of life.</li> </ul>
Action 1: Lecture content includes applications and advances in subject knowledge of new techniques.  Action 2: Students were mentored to work for better achievement forever.  Action 3: Students were motivated to improve their participation in technical/social/extra-curricular activities.			

**Table B.8.5.2b PO Attainment Levels and Actions for improvement for 2016-17**

**Attainment of PO's From I Year Courses in the year  
Session: 2016-17**

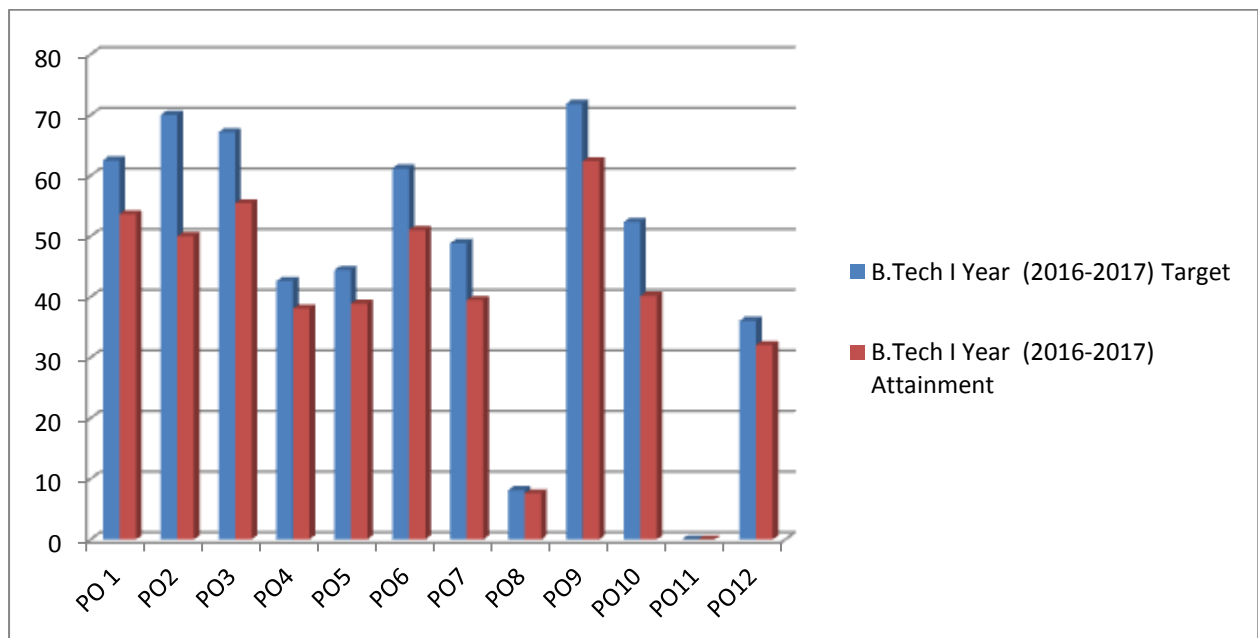

**Figure 8.5.2b Attainment of PO's From I Year Courses in the year 2016-17**



## Gap fulfilling activities

Based on the above observations following actions are taken to overcome the gap

### 1. To attain PO 1 : Facilitating & making them learn the use of E- resources while learning:

- Soft copy of notes is provided to students for reference.
- One or two questions are given in assignment which is to be searched from internet only.

- List of online books is circulated among students which are ready to use on college server.

2. To attain PO 2: Remedial/Problem Solving Classes



- **J-Techtrix(Project Exhibition) Organized by 1<sup>st</sup> Year (Session: 15-16, 16-17, 17-18)**



### 3. To attain PO4: Mentoring by Class Coordinators



**4. To attain PO 5: Motivating students to participate in technical activities**



**5. To attain PO6 & PO10: Using Innovative teaching methods in class & outside class in the form of Industrial Visit.**

- Presentation by students in class



- Some Pics of Industrial Visit of I Year Students [Session: 2017-18]



6. To attain PO7: Students are motivated to celebrate Clean & Green Campus Day and making it a Regular Practice



7. To attain PO8: Social , cultural and moral values are imbibed into them



8. To attain PO 9: Making them learn to be ready for Social Cause:





9. To attain PO 12: Making Induction more informative and interactive to provide a new comer a feeling of trust and belongingness.





CRITERION 9	Student Support Systems	50
-------------	-------------------------	----

**9. STUDENT SUPPORT SYSTEMS (50)**

**9.1 Mentoring System to help at individual level (5)**

*Type of mentoring: Professional guidance/ career advancement/ course work specific/ laboratory specific/ all round development. Number of faculty mentors: Number of students per mentor: Frequency of meeting*

**Professional Guidance/ Career Advancement**

An effective student mentoring system has already been implemented in our college to mentor throughout activities, performance and over all development of students.

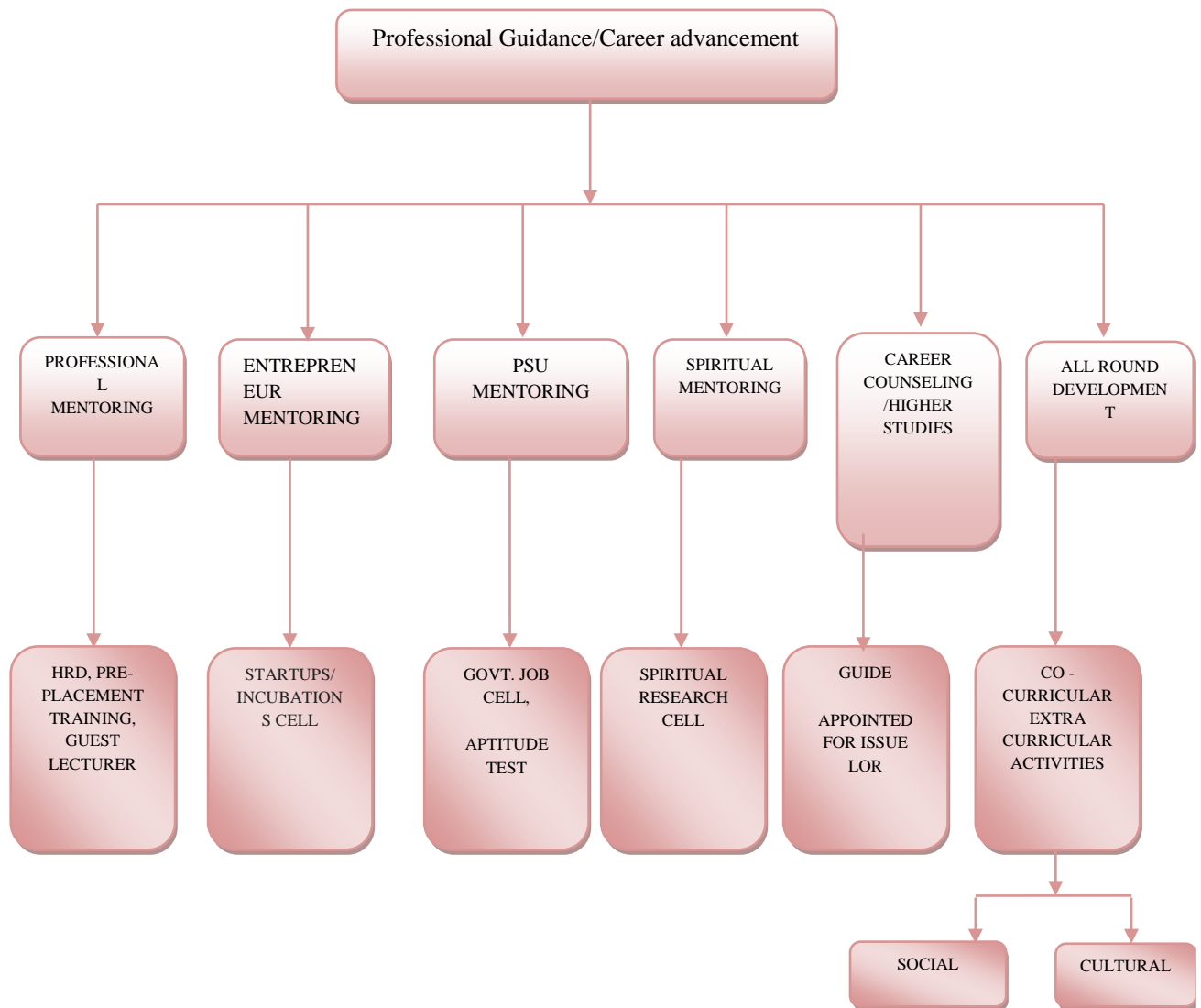

**Fig 9.1a: Professional Guidance/ Career Advancement**



## [SELF ASSESSMENT REPORT]



S.No.	Type of Mentoring	Name
1	PSU Mentoring	Mr. P.K. Tiwari (Rtd. IPS)
		Mr. O.P. Jain (Rtd. IRS)
2	Professional Mentoring	Dr. S.N.Gupta
		Mr. Mukt Bihari
3	Entrepreneur Mentoring	Mr. Siddharth Chaturvedi
4.	Spritual Mentoring	Mr. Mukesh Agrwal
5.	Higher Studies Mentoring	Ms. Neelakshi Chaturvedi
6.	Overall Development	Mr. Anshul Mittal

*Table B.9.1a*

### ➤ Professional mentoring

We have Human Resource & Development cell (HRD), senior advisor and many senior dignitaries who guide students for their career and placement.

Different interactive sessions for students with Dr. S. N.Gupta (senior advisor), Mr. Mukut Bihari and other senior member are organized to motivate and guide them for enhancing career.

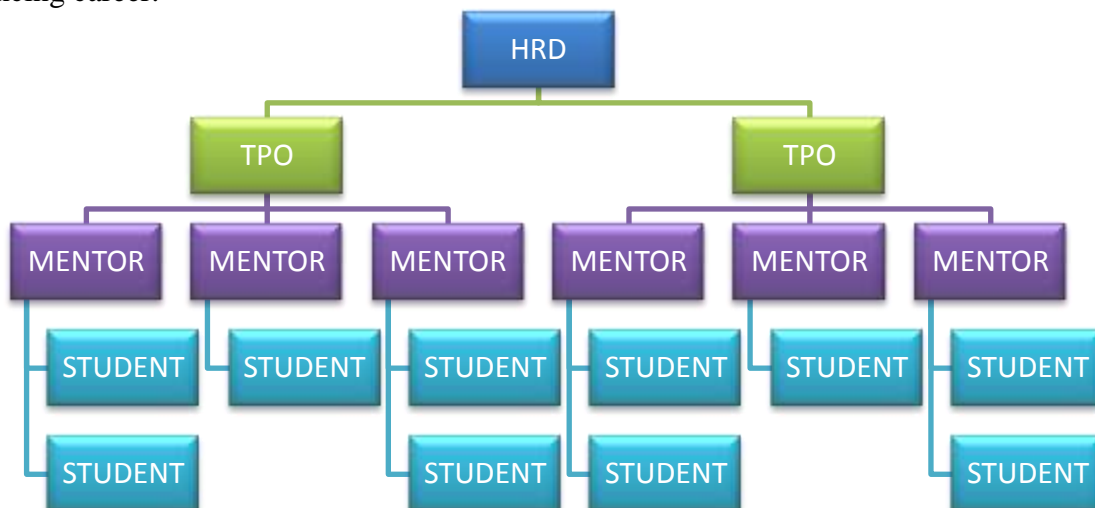

**Fig.9.1b: Professional mentoring**

- **Resume writing sessions:** Organized for students to guide them for effective resume writing.

S.No.	Year	Speaker	Date	No. of participants
1	2015-16	Mr. P.K.Tiwari	23 July,2015	104
2	2016-17	Mr. P.K.Tiwari	25 July,2016	97
3	2017-18	Mr. P.K.Tiwari	21 July,2017	109

*Table B.9.1b*

# [SELF ASSESSMENT REPORT]



- Training conducted for the improvement of professional skills of students in campus itself.

Year	Name of event	Object of event	No. of students participated	Date of event
2015-16	Pre Placement training Program by FACE	Bridging gap between academics & Industry	134	22-07-2015 to 13-08-2015
2016-17	Pre placement training by FACE	Bridging gap between academics & Industry	116	18-7-2016 to 6 -8-2016
2017-18	Pre placement training program by FACE	Bridging gap between academics & Industry	133	20-7-2017 to 14-08-2017

*Table B.9.1c*

## Pre-Placement Training Time Table (Sample)

**Session 2015-16**

Preplacement Training- Batch'17												
S. No.	Class	8:30-9:30	9:30-10:10	10:10-10:50	10:50-11:30	11:30-12:00	12:00-1:30	1:00-1:40	1:40-2:20	2:20-3:00	3:15-4:30	
Mon 25 July	7MEA LT11	APT				B R E A K	Tech-1 B'19 C/C++	PI Tech1 & 2			CBT	
								GD-Slot 1	GD-Slot 2	GD-Slot 3		
	7MEB LT12	APT					Tech-2 LT12	PI Tech1 & 2-			CBT	
							GD-Slot 1	GD-Slot 2	GD-Slot 3			
	7MEC LT11	Tech-1 B'19 C/C++	PI Tech1 & 2				APT				CBT	
			GD-Slot 1	GD-Slot 2	GD-Slot 3		PIHR1 & 2					
Tue 26 July	7MEA LT11	APT				Tech-1 B'19	PIHR1 & 2			CBT		
							GD-Slot 1	GD-Slot 2	GD-Slot 3			
	7MEB LT12	APT					GD-Slot 1	GD-Slot 2	GD-Slot 3	Tech-1 B'19 C/C++	CBT	
	7MEC LT11	PIHR1 & 2			Tech-1 B'19 C/C++	APT						
			GD-Slot 1	GD-Slot 2	GD-Slot 3	PI Tech1 & 2						
Wed 27 July	7MEA LT11	APT				Tech-1 B'19 C/C++	GD-Slot 1	GD-Slot 2	GD-Slot 3	PI Tech1 & 2		CBT
							PIHR1 & 2 - EDC					
	7MEB LT12	APT				Tech-2 LT12	GD-Slot 1	GD-Slot 2	GD-Slot 3	PI Tech1 & 2		CBT
	7MEC LT11	Tech-1 B'19 C/C++	GD-Slot 1	GD-Slot 2	GD-Slot 3	PIHR1 & 2 - EDC			APT			
			PI Tech1 & 2			APT						
			PIHR1 & 2			APT						

# [SELF ASSESSMENT REPORT]



Preplacement Training- Batch'17												
S.No.	Class	8:30-9:30	9:30-10:10	10:10-10:50	10:50-11:30	11:30-12:00	12:00-1:00	1:00-1:40	1:40-2:20	2:20-3:00	3:15-4:30	
Thu 28 July	7MEA LT11	APT				B R E A K	Tech-1 B <sup>+</sup> 19 C/C++	PI Tech1 & 2			CBT	
	7MEB LT12	APT						Tech-2 LT12	PIHR1 & 2			
		GD-Slot 1			GD-Slot 2				GD-Slot 3			
7MEC LT11	Tech-1 B <sup>+</sup> 19 C/C++	PI Tech1 & 2			APT			CBT				
FIHR1 & 2			GD-Slot 1				GD-Slot 2		GD-Slot 3			
Fri 29 July	7MEA LT11	APT					B R E A K	Tech-1 B <sup>+</sup> 19	PIHR1 & 2			CBT
	7MEB LT12	APT							Tech-2 LT12 C/C++	PI Tech1 & 2		
		GD-Slot 1			GD-Slot 2			GD-Slot 3		PIHR1 & 2		
7MEC LT11	Tech-1 B <sup>+</sup> 19	FIHR1 & 2			APT			CBT				
GD-Slot 1			GD-Slot 2	GD-Slot 3	PI Tech1 & 2							
Sat 30 July	7MEA LT11	APT				B R E A K		Tech-ET19	PIHR1 & 2			CBT
	7MEB LT12	APT							Tech-2 LT12 C/C++	PI Tech1 & 2		
		GD-Slot 1			GD-Slot 2			GD-Slot 3		PIHR1 & 2		
7MEC LT11	Tech-1 B <sup>+</sup> 19	FIHR1 & 2			APT			CBT				
GD-Slot 1			GD-Slot 2	GD-Slot 3	PI Tech1 & 2							

# [SELF ASSESSMENT REPORT]



Preplacement Training- Batch'17													
S. No.	Class	8:30-9:30	9:30-10:10	10:10-10:50	10:50-11:30	11:30-12:00	12:00-1:00	1:00-1:40	1:40-2:20	2:20-3:00	3:15-4:30		
Mon 1 Aug	7MEA LT11	APT				B R E A K	Tech-1 BT19 C/C++	PI Tech1 & 2			CBT		
	7MFB LT12	APT						Tech-2 T12	PI Tech1 & 2			CBT	
		APT							PIHR1 & 2				
7MEC LT11	Tech-1 BT13	PI Tech1 & 2			GD-Slot 1		GD-Slot 2	GD-Slot 3	APT			CBT	
7MEA LT11		APT							PIHR1 & 2				CBT
		7MEB LT12	APT						PI Tech1 & 2				
Tue 2 Aug	7MEC LT11	PIHR1 & 2			Tech-1 BT19		PIHR1 & 2			CBT			
	7MEA LT11	APT					PI Tech1 & 2				CBT		
		PI Tech1 & 2					Tech-2 LT12 C/C++					CBT	
Wed 3 Aug	7MEA LT11	APT				B R E A K	Tech-BT15	PIHR1 & 2			CBT		
	7MEB LT12	AP						Tech-1 LT12	PI Tech1 & 2			CBT	
		APT							API				CBT
7MEC LT11	Tech-1 BT13	PI Tech1 & 2			GD-Slot 1		GD-Slot 2	GD-Slot 3	APT			CBT	
7MEA LT11		APT							PIHR1 & 2				CBT
		7MEB LT12	APT						PI Tech1 & 2				

Preplacement Training- Batch'17														
S. No.	Class	8:30-9:30	9:30-10:10	10:10-10:50	10:50-11:30	11:30-12:00	12:00-1:00	1:00-1:40	1:40-2:20	2:20-3:00	3:15-4:30			
Thu 4 Aug	7MFA LT11	APT				B R E A K	Tech-BT15	PI Tech1 & 2			CBT			
	7MEB LT12	APT						Tech-2 LT12	PIHR1 & 2			CBT		
		APT							PI Tech1 & 2				CBT	
7MEC LT11	Tech-1 BT13	PI Tech1 & 2			GD-Slot 1		GD-Slot 2	GD-Slot 3	APT			CBT		
7MEA LT11		APT							PIHR1 & 2				CBT	
		7MEB LT12	APT						PI Tech1 & 2					CBT
Fri 5 Aug	7MEA LT11	Reserved Day					B R E A K	Reserved Day					CBT	
	7MEB LT12	Reserved Day						Reserved Day						CBT
	7MEC LT11	Reserved Day						Reserved Day						
Sat 6 Aug	7MEA LT11	CBT	PI-Tech1			GD1, GD2		PI-HR1			CBT			
	7MEB LT12		PI-Tech2					PI-HR2				CBT		
			PI-Tech3					PI-HR3						
7MEC LT11	CBT	PI-HR1			GD1, GD2	PI-Tech1			CBT					
		PI-HR2				PI-Tech2								
		PI-HR3				PI-Tech3								
7MEC LT11	CBT	PI-Tech1			GD1, GD2	PI-HR1			CBT					
		PI-Tech2				PI-HR2								
		PI-Tech3				PI-HR3								

# [SELF ASSESSMENT REPORT]



## Pre-Placement Training Time Table (Sample) Session 2016-17

Session 2016-17 Pre-placement Training						
Date	8:30 - 9:00	9:00 - 12:00	12:00 - 12:30	12:30 - 1:30	1:30 - 2:30	2:30 - 3:30
<b>18-Jul</b>	<b>Booklet</b> 1. Numbers 2. GD	<b>CBT</b>	<b>BREAK</b>			
<b>19-Jul</b>	<b>Booklet</b> 1. Data Arrangement and 2. Data Interpretations	<b>CBT</b>				
<b>20-Jul</b>	<b>Booklet</b> 1. Sentence Corrections 2. Sentence Completion and Para-jumbles	<b>CBT</b>				
<b>21-Jul</b>	<b>Booklet</b> 1. P&C and Probability 2. Percentage	<b>CBT</b>				
<b>22-Jul</b>	<b>Booklet</b> 1. Time & Work 2. Clocks & calendars	<b>CBT</b>				
<b>23-Jul</b>	<b>Booklet</b> 1. Profit and Loss	<b>CBT</b>				

# [SELF ASSESSMENT REPORT]



## Pre-Placement Training Time Table (Sample) Session 2017-18

7MEA									
PI-Tech1: _____, PI-Tech2: _____; PI-HR1: _____, PI-HR2: _____; GD: _____									
Fill all venues and faculty names									
Date	8:30-9:30	9:30-10:30	10:30-11:30	11:30 - 12:00	12:00-1:00	1:00-2:00	2:00-3:00	3:00-4:00	Check List
24-Jul	APT			BREAK	Tech-1 Subject Faculty	PI Tech1 & 2 ( , )	CBT1		
						PI HR1 & 2 ( , )			
						GD- Slot ( )			
25-Jul	APT				Tech-2 Subject Faculty	PI HR1 & 2 ( , )	CBT2		
						GD- Slot ( )			
						PI Tech1 & 2 ( , )			
26-Jul	APT				Tech-3 Subject Faculty	GD- Slot ( )	CBT3		
						PI Tech1 & 2 ( , )			
						PI HR1 & 2 ( , )			
27-Jul	APT				BREAK	Tech-4 Subject Faculty	PI Tech1 & 2 ( , )		CBT4
							PI HR1 & 2 ( , )		
							GD- Slot ( )		
28-Jul	APT			Tech-5 C&C++ NM		PI HR1 & 2 ( , )	CBT5		
						GD- Slot ( )			
						PI Tech1 & 2 ( , )			
29-Jul	APT			Tech-6 C&C++ NM		GD- Slot ( )	CBT6		
						PI Tech1 & 2 ( , )			
						PI HR1 & 2 ( , )			
31-Jul	APT			BREAK		Tech-7 C&C++ NM	PI Tech1 & 2 ( , )	CBT7	
							PI HR1 & 2 ( , )		
							GD- Slot ( )		
01-Aug	APT				Tech-8 C&C++ NM	PI HR1 & 2 ( , )	CBT8		
						GD- Slot ( )			
						PI Tech1 & 2 ( , )			
02-Aug	APT				Tech-9 Subject Faculty	GD- Slot ( )	CBT9		
						PI Tech1 & 2 ( , )			
						PI HR1 & 2 ( , )			
03-Aug	APT				BREAK	Tech-10 Subject Faculty	PI Tech1 & 2 ( , )	CBT10	
							PI HR1 & 2 ( , )		
							GD- Slot ( )		
04-Aug	APT			Tech-11 Subject Faculty		PI HR1 & 2 ( , )	CBT11		
						GD- Slot ( )			
						PI Tech1 & 2 ( , )			
05-Aug	APT			Tech-12 Subject Faculty		GD- Slot ( )	CBT12		
						PI Tech1 & 2 ( , )			
						PI HR1 & 2 ( , )			

# [SELF ASSESSMENT REPORT]



7MEB PI-Tech1: ____, PI-Tech2: ____, PI-HR1: ____, PI-HR2: ____; GD: ____ Fill all venues and faculty names											
Date	8:30-9:30	9:30-10:30	10:30-11:30	11:30 - 12:00	12:00-1:00	1:00- 3:00	3:00-4:00	Check List			
24-Jul	APT			BREAK	Tech-1 Subject Faculty	PI Tech1 & 2 ( , )	CBT1	PI(Tech)-1 PI(HR)-1 GD-1 Tech-3 CBT-3 APT-3			
25-Jul	APT					Tech-2 Subject Faculty			PI HR1 & 2 ( , )	CBT2	
									GD- Slot ( )		
26-Jul	APT				Tech-3 Subject Faculty	PI Tech1 & 2 ( , )	CBT3				
						PI HR1 & 2 ( , )					
27-Jul	APT				BREAK	Tech-4 Subject Faculty	PI Tech1 & 2 ( , )		CBT4		
28-Jul	APT						Tech-5 Subject Faculty			PI HR1 & 2 ( , )	CBT5
										GD- Slot ( )	
29-Jul	APT					Tech-6 Subject Faculty	PI Tech1 & 2 ( , )		CBT6		
				PI HR1 & 2 ( , )							
31-Jul	APT			BREAK		Tech-7 Subject Faculty	PI Tech1 & 2 ( , )	CBT7			
01-Aug	APT						Tech-8 Subject Faculty		PI HR1 & 2 ( , )	CBT8	
									GD- Slot ( )		
02-Aug	APT					Tech-9 C&C++ NM	PI Tech1 & 2 ( , )	CBT9			
					PI HR1 & 2 ( , )						
03-Aug	APT				BREAK	Tech-10 C&C++ NM	PI Tech1 & 2 ( , )	CBT10			
04-Aug	APT						Tech-11 C&C++ NM		PI HR1 & 2 ( , )	CBT11	
									GD- Slot ( )		
05-Aug	APT					Tech-12 C&C++ NM	PI Tech1 & 2 ( , )	CBT12			
				PI HR1 & 2 ( , )							

# [SELF ASSESSMENT REPORT]



Branch	Date	8:30-10:00	10:00-11:30	11:30 - 12:30	12:30-2:00	2:00-3:30
MEA MEB	20-Jul	CBT @ Home		<b>BREAK</b>	Orientation Program	Motivation and Material distribution (TPO & HoD)
	21-Jul	CBT @ Home			C, C++ (MEA & MEB, C-401 ) By NM Project / Seminar (EEA , C-501) By (CEA, __) By __	C, C++ (EEA & CEA, C-501) By AM Project / Seminar MEA & MEB, C-401 ) By —
	22-Jul	CBT @ Home			Resume writing	Interview skills

Topic wise time table						
Subject	Date	8:30-10:00	10:00-11:30	11:30 - 12:30	12:30-2:00	2:00-3:30
OP MA & __	20-Jul	Orientation Program	Orientation Program		Orientation Program	Orientation Program
RW+IS PKT	21-Jul	Resume writing	Interview skills		Resume writing	Interview skills
	22-Jul	Resume writing	Interview skills		Resume writing	Interview skills
Subject	Date	8:30-10:00	10:00-11:30	11:30 - 12:30	12:30-2:00	2:00-3:30
	21-Jul	MEC & IT C-401 NM	EEB & CEB C-501 AM	<b>BREAK</b>	MEA & MEB C-401 NM	EEA & CEA C-501 AM
	22-Jul	ECA & ECB C-401 NM	CSA & CSB C-501 AM		ECC & ECD C-401 NM	CSC & CSD C-501 AM
Subject	Date	8:30-10:00	10:00-11:30	11:30 - 12:30	12:30-2:00	2:00-3:30
	21-Jul	EEB - C501 By __ CEB - TBD By __	MEC- TBD By __ IT-C401 By __	<b>BREAK</b>	EEA , C-501 By __ CEA,TBD By __	MEA & MEB, C-401 By __
	22-Jul	CSA & CSB, C-501 By NC	ECA & ECB, C-401 By __		CSC & CSD, C-501 By NC	ECC & ECD, C-401 By __
Subject	Date	8:30-10:00	10:00-11:30	11:30 - 12:30	12:30-2:00	2:00-3:30
Motivation & Material distribution Venue: Department	20-Jul	MEC IT EEB CEB (TPO & HoD)	ECA,ECB (TPO & HoD)  CSA,CSB (TPO & HoD)		ECC,ECD (TPO & HoD)  CSC,CSD (TPO & HoD)	MEA, MEB (TPO & HoD)  EEA CEA (TPO & HoD)



# [SELF ASSESSMENT REPORT]



Mock-Drill 8-9 August					
Group No.	Classes	9-11am	11:30	12:30	02:30
08-Aug	7 CSE 7 ECE	CBT  CSE - IBM, CP1, CP2, CP3, CP4, CP8 CP22, CP23, CP27  ECE- EE-CAD, ECE- CAD, ME-CAD, CP14, CP15 CP18, CP19, CP20, CP21	GD GD1 - Meeting Room GD2 - EDC Conf. Room GD3 - Conf Hall GD4 - LH4	Tech 1. CS - CP1 2. CS - CP2 3. CS - CP3 4. CS - CP4 5. CS - IBM 6. CS - IBM 7. CS - IBM 8. EC1 - CP7 9. EC2 - CP7 10. EC3 - CP8	HR 1. Sh. PKT - Offc 2. Prof. Mukt Bihari- Offc 3. Prof. S. N. Gupta - IL1 4. JU - IL 2 5. JU - IL 3 6. JU - CP5 7. Saguna Chaturvedi-Offc 8. Alok Bhargav - CP6
09-Aug	7 ME 7 EE 7 IT 7 CE	CBT  CSE - IBM, CP1, CP2, CP3, CP4, CP8 CP22, CP23, CP27  ECE- EE-CAD, ECE- CAD, ME-CAD, CP14, CP15 CP18, CP19, CP20, CP21	GD GD1 - Meeting Room GD2 - EDC Conf. Room GD3 - Conf Hall GD4 - LH4	Tech 1. EE - CP1 2. EE - CP2 3. IT - CP3 4. IT - CP4 5. ME - IBM 6. ME - IBM 7. ME - IBM 8. CE - CP7 9. CE - CP7 10. EE - CP8	HR 1. Sh. PKT - Offc 2. Prof. Mukt Bihari- Offc 3. Prof. S. N. Gupta - IL1 4. JU - IL 2 5. JU - IL 3 6. JU - CP5 7. Saguna Chaturvedi-Offc 8. Alok Bhargav - CP6

Need Based Training (Level - 3)								
1. C&C++(4)    2. PI-Tech(4)    3. PI-HR(4)    4. GD(4)    5. CBT(8)    6. APT(24)								
Date	8:30- 9:30	9:30- 10:30	10:30- 11:30	11:30- 12:00	12:00 - 1:00	1:00 - 2:00	2:00 - 3:00	3:00 - 4:00
11-Aug	C&C++	PI-Tech	PI-HR	BREAK	GD	CBT	CBT	CBT
12-Aug	C&C++	PI-Tech	PI-HR		GD	CBT	CBT	CBT
13-Aug	C&C++	PI-Tech	PI-HR		GD	CBT	CBT	CBT
14-Aug	C&C++	PI-Tech	PI-HR		GD	CBT	CBT	CBT

# [SELF ASSESSMENT REPORT]



Company Specific Training (Level - 4)									
Date	8:30-9:30	9:30-10:30	10:30-11:30	11:30-12:00	12:00 - 1:00	1:00 - 2:00	2:00 - 3:00	3:00 - 4:00	4:00 - 5:00
Day 1	External Agency			BREAK	GD	PI-Tech	PI-HR	CBT	CBT
Day 2	External Agency				GD	PI-Tech	PI-HR	CBT	CBT
Day 3	External Agency				GD	PI-Tech	PI-HR	CBT	CBT
Day 4	External Agency				GD	PI-Tech	PI-HR	CBT	CBT
Day 5	External Agency				GD	PI-Tech	PI-HR	CBT	CBT



**Pre Placement training Program by FACE**



**Pre Placement training Program by ALUMNI**

➤ **Government Job Cell**

The Initiative taken by Prof.(Dr.) Vinay Chandna for making students career in government sector. A cell is under the guidance of Mr. P.K.Tiwari and Mr. O.P.Jain in institute to prepare students towards different competitive examination. In this cell we encourage and inspire students for competitive examination like GATE, CAT, MAT etc.

- Organized classes for GATE aspirants.
- Provided course material to students.
- Career opportunities in government sector are shared with the interested students.

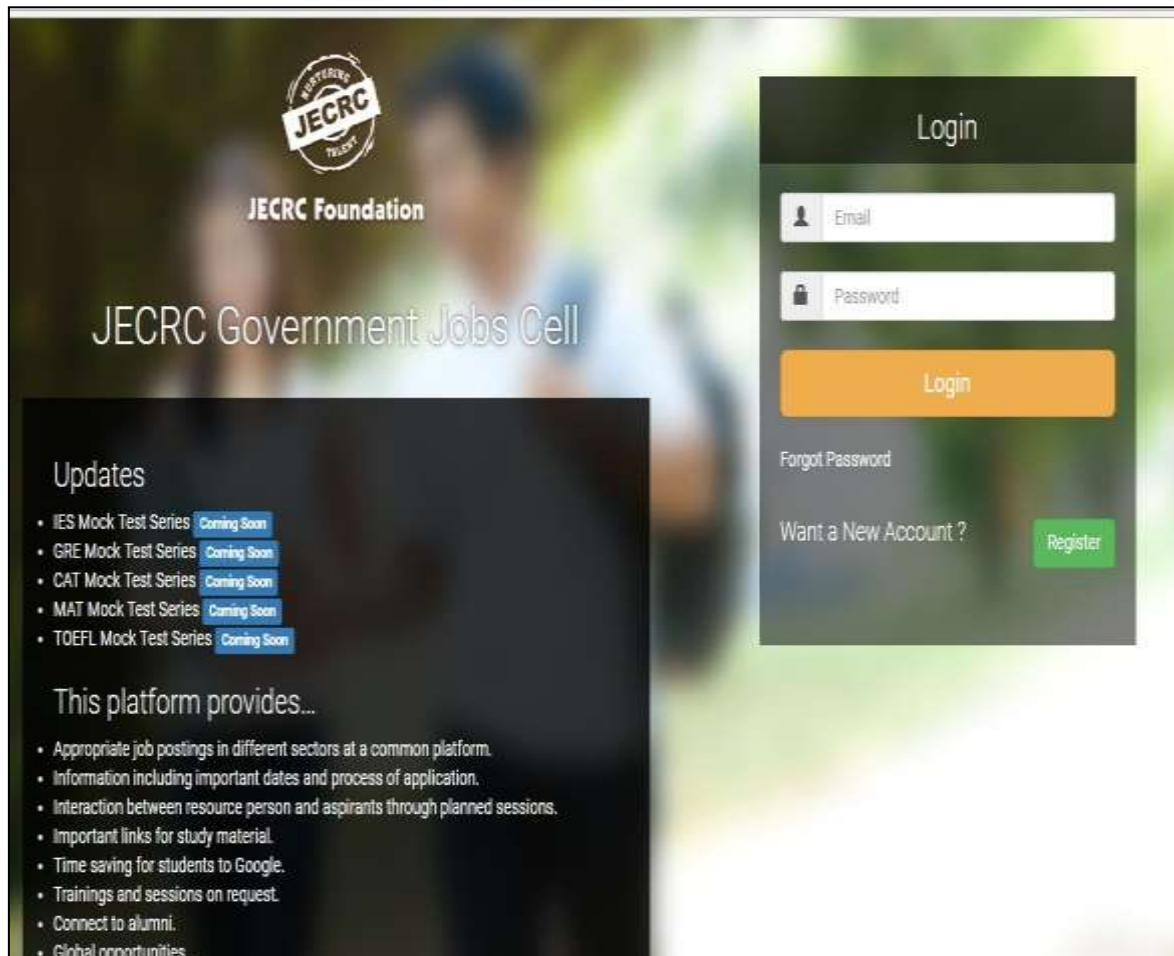

# [SELF ASSESSMENT REPORT]



garena -

[Search Jobs](#)
[About Us](#)
[Central & State Jobs](#)
[Defence](#)
[PSU](#)
[Other Government Jobs](#)
[Activity](#)
[Merchant Navy](#)
[Contact Us](#)

[Study Material](#)



GATE Mock Test

Date: 13 September 2017

Timings: 3 PM- 5 PM

Venue: JECRC College Campus, Block-A, Labs CP1 to CP6

GATE 2017- 18 Data						
Institute Name:		JECRC, JAIPUR				
S. No.	Student Name	Branch	Registered in GATE (Yes/No)	GATE Registration Number	Qualify Gate (Yes/No)	Marks Obtained
1	ABHISHEK RAWAT	ME	YES	ME18S23042226	YES	48.3
2	AISHWERYA JOHARI	ME	YES	ME18S23045103	YES	36.84
3	ARPIT SHARMA	ME	YES	ME18S23041416	YES	45.94
4	ASHISH KUMAR	ME	YES	ME18S23045175	YES	57.74
5	BHAVESH KUMAR PATIDAR	ME	YES	ME18S23041303	YES	43.25
6	HIMANSHU GUNESHWAR	ME	YES	ME18S23041019	YES	36.17
7	HIMANSHU PALIWAL	ME	YES	ME18S23041358	YES	35.16

## [SELF ASSESSMENT REPORT]



8	LILESHWAR SINGH	ME	YES	ME18S13045210	YES	32.88
9	LINCOLN GORI	ME	YES	ME18S13042439	YES	41.78
10	MAYANK SHARMA	ME	YES	ME18S13045126	YES	35.85
11	MUDIT GARG	ME	YES	ME18S23041687	YES	37.52
12	PALLAV PANDEY	ME	YES	ME18S13043216	YES	38.48
13	PIYUSH KATARIA	ME	YES	ME18S13043039	YES	48.67
14	PRASHANT PRAJAPATI	ME	YES	ME18S23042420	YES	51
15	RAHUL GAHLOT	ME	YES	ME18S13045130	YES	35.85
16	RAJA JANMEJAY	ME	YES	ME18S13045131	YES	43.43
17	SAURABH MANGAL	ME	YES	ME18S13043045	YES	54.31
18	SHUBHAM HEDA	ME	YES	ME18S23043259	YES	42.57

### ➤ Entrepreneur cell

Entrepreneurship cell is established in mentorship of Mr. Siddharth Chaturvedi, our college for encouraging and inspiring students for startups and entrepreneur. Various interactive sessions for students with alumni and startup representative are organized to know the importance of being an entrepreneur and ways to get financial assistance to become an entrepreneur.

Cell is responsible for:

1. Initiative and Development of Startups/Incubations
2. Initiative towards centre of excellence
3. Relationship with companies
4. Motivate students, guide and help them in the same direction.

An *Entrepreneurship awareness camp organized on 2<sup>nd</sup> Sep, 2016* in which our students and faculties participated.

- Institute has success stories for every pass out year as a result of Entrepreneurship cell and incubation center.

S.No	Name	Batch	Branch	Organisation	Present Location
1	Narendra Tejwani	2016	ME	Frootella Private Limited	Mumbai
2	Parth Mittal	2017	ME	BrunchCare.com	Kota
3	Akash Jain	2017	ME	Chilling Badmash Company Shelter the need of life Champs11 Media Pvt. Ltd.	Jaipur
4	Akash Jain	2017	ME	Chilling Badmash Company Shelter the need of life Champs11 Media Pvt. Ltd.	Jaipur

5	Gaurav	2017	ME	Bharat Timber Industries	Jaipur
---	--------	------	----	--------------------------	--------

## Spiritual Mentoring

A special initiative has been taken by our institute in the form of SPIRITUAL RESEARCH CELL. The cell was established on 6<sup>th</sup> October, 2016. The inauguration was done by the auspicious presence of the Executive Secretary, Brahmakumaris & Vice Chairman, Rajyoga Education & Research Foundation, Rajyogi Mruthyunjaya Ji, Dr. U.S Agarwal, Principal, SMS Medical College, Jaipur and Meditation Expert, B K Sushma Ji. This cell motivates students mentally and builds up their confidence.



Spiritual cell

## ➤ Career Counseling /Higher studies

A Guide has been appointed specifically for higher study counseling and career counseling in December 2016. She counseled many students and encouraged them for further studies. She guided students on the right path for career. She also issued letter of recommendation (LOR) to some students.

## [SELF ASSESSMENT REPORT]



S.No.	Dept. Name	No. of LOR issued (Approx)
1	ME	17

No. of students admitted to higher studies with valid qualifying scores (GATE or equivalent State or National Level Tests, GRE, GMAT etc.)	CAYm1 (2016-17)	CAYm2 (2015-16)	CAYm3 (2014-15)
	09	13	12

### ➤ All round Development

Student Development Officer Mr. Anshul Mittal is responsible for the overall development of student. His responsibility is to encourage students to participate in different co curricular and extracurricular activities.

### SDO Responsibilities:

- Planning, developing and delivering a variety of student services and activities (co-curricular and extracurricular activities)
- Motivate and engage students also oversee students activity on campus
- Handles promotions of college events manual and e-promotions

### Extracurricular activity:

S.NO.	Activity/Event	Date
1	Blood Group check-up camp	11 Sep, 2017
2	Engineers Day	15 Sep, 2017
3	Swachhta Pakhwada	1 to 15 Sep,2017
4	Interactive Session with Dr. Kiran Seth	8 Sep 2017
5	Rally on rivers Seminar	26 Sep,2017
6	OMEN gaming Championship	7 Oct,2017
7	Interactive session with Mr. Niko Philips	1 Nov, 2017
8	VandeMataram-Voice of Unity	8 Nov, 2017
9	National Girl Child Day Celebration,	24 Jan, 2018
10	Orphanage Children Interactive Program	12 Feb, 2018
11	Soch	12 Feb 2018
12	Renaissance 2018	25 to 28 March 2018
13	Seminar on Careers in Entertainment Industry	12 Narch 2018

**Course Work Specific/ Laboratory Specific**

- For II and III year we have Tutor Guide (TG) who follows instructions given by Class Coordinator (CC).
- Counseling of irregular students to attend regularly laboratory classes and complete backlog experiments during specified extra hours.

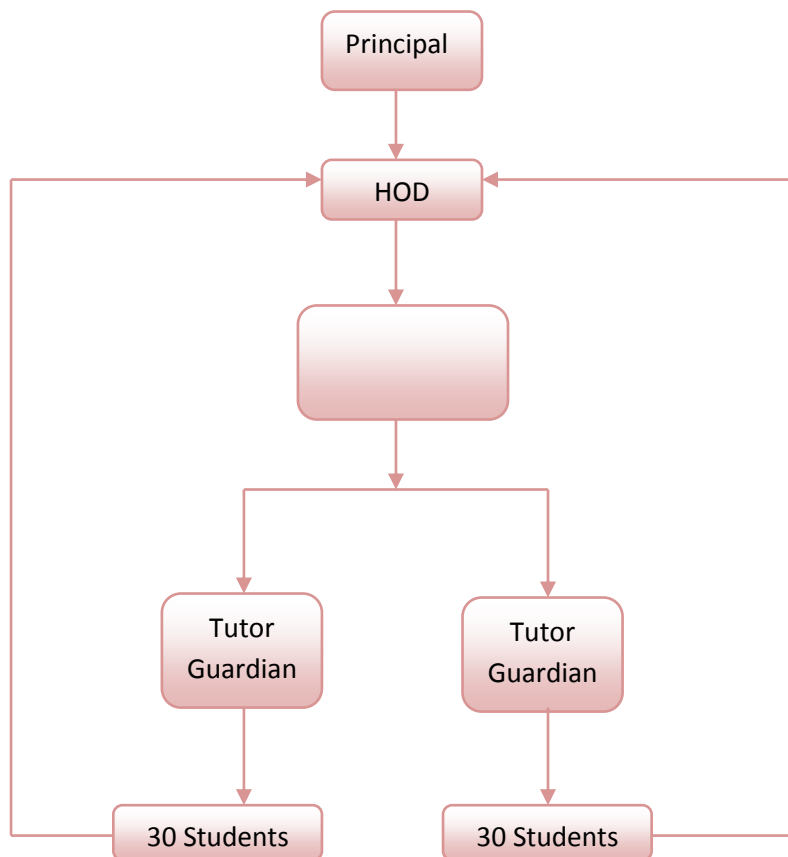

**Class Coordinator Responsibilities:**

- Creating learning opportunities and motivating the student community.
- Providing guidance on academic, personal and career matters.
- Resolving academic issues of students.
- Tracking academic and extra-curricular performance of students.
- Meet the students periodically and monitor their performance and their activities

**No of students per class coordinator:** around 20-25

S.No.	Year	No of Class coordinator
1	2015-16	6
2	2016-17	6
3	2017-18	6

- For IV year we have Mentor Mentee system for guiding students also.



## [SELF ASSESSMENT REPORT]



The mentor is a model, a guide by the side, a motivator, a trainer and a counselor to the student.

Mentoring is a process for the informal transmission of knowledge and the psychosocial support. Mentoring entails informal communication, usually face-to-face and during a sustained period of time, between a person who is perceived to have greater relevant knowledge, wisdom, or experience (the mentor) and a person who is perceived to have less.

### **Mentor's Responsibilities:**

- Take an interest in developing student's career and well-being.
- Mentors keep track of their students' progress and achievements, setting milestones and acknowledging accomplishments.
- Monitor student's readiness for Personal Interview (including Resume, Dressing sense etc.)
- **Evaluate Student Progress and Performance in Computer Based Tests. Keep record of his/her attendance in the preparatory classes and keep the department HOD informed.**
- **Encourage students for attending all the sessions for sure success.**
- **Informing students about the profile of companies coming for recruitment as per information obtained from placement department.**
- **Engage the Student beyond the Classroom especially for communication practices and emphasize the importance of communication for sure success.**
- Keep the department / panel members informed, if any student is not taking his/her sessions seriously.
- Guide student for practical training and project presentation.
- Guide students for technical interview.
- Guide and Evaluate student for GD for companies requiring GD.
- Guide students for General Knowledge about Industries in their domain.
- **Provide Ethical Guidance**

### **No of Students per mentor: Around 14-25**

S.No.	Year	No. of Mentor	No of Students per mentor
1	2015-16	11	14-16
2	2016-17	8	19-20
3	2017-18	6	25-26

### **Session 2015-16 Mentor List**

S. No	Faculty Name	Students Assigned (Serial No.)	Semester	Signature
1	Mr. Ravindra Singh Yadav	12EJCME001 To 12EJCME015	VII-A	
2	Prof. R. O. Rustagi	12EJCME016 To 12EJCME029	VII-A	
3	Mr. Akhil Vijay	12EJCME030 To 12EJCME044	VII-A	
4	Mr. Bhuvnesh Bhardwaj	12EJCME044 To 12EJCME059	VII-A	
5	Mr. Rishi Kumar	12EJCME060 To 12EJCME073	VII-A	
6	Mr. Kuldeep Sharma	12EJCME074 To 12EJCME087	VII-B	

## [SELF ASSESSMENT REPORT]



7	Mr. Sandeep Yadav	12EJCME088 To 12EJCME101	VII-B	
8	Mr. Pawan Gupta	12EJCME102 To 12EJCME116	VII-B	
9.	Mr. Aashish Nagpal	12EJCME117 To 12EJCME130	VII-B	
10.	Prof. R. Govindraj	12EJCME131 To 13EJCME308	VII-B	
11.	Dr. Manish Srivatsava	13EJCME309 To 13EJCME323	VII-B	

### Session 2016-17 Mentor List

S. No	Faculty Name	Students Assigned (Serial No.)	Semester	Signature
1	Mr. Veerendra Kumar	13EJCME001 To 13EJCME018	VII-A	
2	Mr. Manish Srivatsava	13EJCME019 To 13EJCME038	VII-A	
3	Mr. Bharat Sharma	13EJCME039 To 13EJCME056	VII-A	
4	Mr. Aashish Nagpal	13EJCME057 To 13EJCME075	VII-A	
5	Mr. Tejendra Singh	13EJCME076 To 13EJCME096	VII-B	
6	Mr. Kuldeep Shrama	13EJCME097 To 13EJCME116	VII-B	
7	Mr. Nikhil Jain	13EJCME117 To 13EJCME856	VII-B	
8	Mr. Ravi Yadav	13EJCME857 To 13EJCME215	VII-B	

### Session 2017-18 Mentor List

S. No	Faculty Name	Students Assigned (Serial No.)	Semester	Signature
1	Mr. Akhil Vijay	14EJCME001 To 14EJCME026	VII-A	
2	Mr. Aashish Nagpal	14EJCME027 To 14EJCME054	VII-A	
3	Dr. Bhuvnesh Bhardwaj	14EJCME055 To 14EJCME082	VII-A	
4	Mr. Manish Srivatsava	14EJCME083 To 14EJCME108	VII-B	
5	Mr. Satyendra Kumar	14EJCME109 To 14EJCME304	VII-B	
6	Mr. Hement Bansal	15EJCME200 To 15EJCME223	VII-B	

### 9.2. Feedback analysis and reward /corrective measures taken, if any (10)

*Feedback collected for all courses: YES/NO; Specify the feedback collection process; Average Percentage of students who participate; Specify the feedback analysis process; Basis of reward/corrective measures, if any; Indices used for measuring quality of teaching & learning and summary of the index values for all courses/teachers; Number of corrective actions taken.*

## [SELF ASSESSMENT REPORT]



- Feedback collected for all courses: **YES**
- Specify the feedback collection process: **Google form**
- Average Percentage of students who participate: **Approximate 80%**

### Feedback collection process

Items	Description
Feedback collection process	YES for all courses
Process	Computerized using software
Feedback receiver	HoD
Frequency of feedback collection	Once in a semester (but oral feedback from the students is taken by HoD almost every month)
Metrics used for calculation	5-Excellent 4-very good 3-good 2-satisfactory 1-below average
Purpose of comment	For improving the quality of teaching learning process

### Specify the feedback analysis process:

The feedback collected from students is first analyzed by internal quality assurance committee (IQAC), headed by the HoD.

- Performance of each individual faculty is assessed by the concerned committee members.
- The contents of the feedback will be shared with each faculty member individually.

All the courses mentioned in the feedback form will be analyzed as follows:

Step-1	Collection of feedback forms for all the subjects from the students based on parameters specified in feed back form.
Step-2	Estimation of mean for all the parameters.
Step-3	After the recommendations of IQAC, threshold value will be finalized. The normal value setup at present is 3.
Step-4	If the threshold exceeds from 3, it will be considered as good. If it is less, the faculty performance is considered as average or below average.
Step-5	If the faculty receives good performance, he will be rewarded. If he / she receives average or below average performance, he / she gets counseling and allows them to get correct their performances.

### System of reward

**System of reward process: Faculty reward is given based on the following factors:**

1. Student's feedback (Format enclosed)
2. The faculty's self-appraisal report (Format enclosed)
3. The marks given by internal quality assurance committee (IQAC), headed by HOD.
4. If the faculty achieves 60% or more than 60%, an appreciation from the principal will be rewarded.

# [SELF ASSESSMENT REPORT]



8/29/2018

Feedback Form (2017-2018)

## Feedback Form (2017-2018)

This questionnaire has been designed by JECRC to seek a feedback from the students to strengthen the quality of teaching-learning environment.

Name of the Department \*

Mechanical engineering

Semester \*

7

Section \*

A

# [SELF ASSESSMENT REPORT]



8/29/2018

Feedback Form (2017-2018)

7ME1A: FINITE ELEMENT METHODS Mark: Excellent = 5 / Very Good = 4 / Good = 3 / Avg. = 2 / Below Avg. = 1 \*

	5	4	3	2	1
Punctuality in the Class	<input type="radio"/>	<input checked="" type="radio"/>	<input type="radio"/>	<input type="radio"/>	<input type="radio"/>
Regularity in taking Classes	<input type="radio"/>	<input checked="" type="radio"/>	<input type="radio"/>	<input type="radio"/>	<input type="radio"/>
Students' attendance/ presence in the class of teacher who is being evaluated	<input type="radio"/>	<input checked="" type="radio"/>	<input type="radio"/>	<input type="radio"/>	<input type="radio"/>
Quality of lectures	<input type="radio"/>	<input type="radio"/>	<input type="radio"/>	<input checked="" type="radio"/>	<input type="radio"/>
Makes alternate arrangement of class in his/her absence	<input type="radio"/>	<input checked="" type="radio"/>	<input type="radio"/>	<input type="radio"/>	<input type="radio"/>
Focus on Syllabus	<input type="radio"/>	<input checked="" type="radio"/>	<input type="radio"/>	<input type="radio"/>	<input type="radio"/>
Self-confidence	<input type="radio"/>	<input checked="" type="radio"/>	<input type="radio"/>	<input type="radio"/>	<input type="radio"/>
Communication skills	<input type="radio"/>	<input checked="" type="radio"/>	<input type="radio"/>	<input type="radio"/>	<input type="radio"/>
Conducting the classroom discussions	<input type="radio"/>	<input checked="" type="radio"/>	<input type="radio"/>	<input type="radio"/>	<input type="radio"/>
Completes syllabus of the course in time	<input type="radio"/>	<input checked="" type="radio"/>	<input type="radio"/>	<input type="radio"/>	<input type="radio"/>

Name of Subject Teacher \*

Hemant bansal

# [SELF ASSESSMENT REPORT]



7ME2A: REFRIGERATION AND AIR CONDITIONING Mark: Excellent = 5 /  
Very Good = 4 / Good = 3 / Avg. = 2 / Below Avg. = 1 \*

	5	4	3	2	1
Punctuality in the Class	<input checked="" type="radio"/>	<input type="radio"/>	<input type="radio"/>	<input type="radio"/>	<input type="radio"/>
Regularity in taking Classes	<input checked="" type="radio"/>	<input type="radio"/>	<input type="radio"/>	<input type="radio"/>	<input type="radio"/>
Students' attendance/ presence in the class of teacher who is being evaluated	<input checked="" type="radio"/>	<input type="radio"/>	<input type="radio"/>	<input type="radio"/>	<input type="radio"/>
Quality of lectures	<input checked="" type="radio"/>	<input type="radio"/>	<input type="radio"/>	<input type="radio"/>	<input type="radio"/>
Makes alternate arrangement of class in his/her absence	<input checked="" type="radio"/>	<input type="radio"/>	<input type="radio"/>	<input type="radio"/>	<input type="radio"/>
Focus on Syllabus	<input checked="" type="radio"/>	<input type="radio"/>	<input type="radio"/>	<input type="radio"/>	<input type="radio"/>
Self-confidence	<input checked="" type="radio"/>	<input type="radio"/>	<input type="radio"/>	<input type="radio"/>	<input type="radio"/>
Communication skills	<input checked="" type="radio"/>	<input type="radio"/>	<input type="radio"/>	<input type="radio"/>	<input type="radio"/>
Conducting the classroom discussions	<input checked="" type="radio"/>	<input type="radio"/>	<input type="radio"/>	<input type="radio"/>	<input type="radio"/>
Completes syllabus of the course in time	<input checked="" type="radio"/>	<input type="radio"/>	<input type="radio"/>	<input type="radio"/>	<input type="radio"/>

Name of Subject Teacher \*

Bhuvneshwar bhardwaj

# [SELF ASSESSMENT REPORT]



## Faculty Appraisal Form

**Jaipur Engineering College and Research Centre, Jaipur**

**FACULTY APPRAISAL FORM**

For Best faculty award

Total 200 points

Name of Faculty Member:

Department:

Designation:

S. No.	Item Name	Maximum Points	Points obtained												
1	Academic result 30 points average (90% students having more than 70% : 30 points, 80-89% students having more than 70% result: 27 points, 70-79% students having more than 70% result: 24 points, 60-69% students having more than 70% result: 21, 60-69% students having more than 60% result: 18 points , 50-59% students having more than 60% result: 15 points else ZERO) Example: <table border="1" style="margin-left: 20px; border-collapse: collapse; width: 60%;"> <thead> <tr> <th style="width: 50%;">Theory Subject</th> <th style="width: 50%;">Points obtained</th> </tr> </thead> <tbody> <tr> <td style="text-align: center;">Sub-1</td> <td style="text-align: center;">30</td> </tr> <tr> <td style="text-align: center;">Sub-2</td> <td style="text-align: center;">27</td> </tr> <tr> <td style="text-align: center;">Sub-3</td> <td style="text-align: center;">0</td> </tr> <tr> <td style="text-align: center;">Sub-4</td> <td style="text-align: center;">18</td> </tr> <tr> <td style="text-align: center;">Average points scored</td> <td style="text-align: center;"><b>75/4 i.e. 18.75</b></td> </tr> </tbody> </table>	Theory Subject	Points obtained	Sub-1	30	Sub-2	27	Sub-3	0	Sub-4	18	Average points scored	<b>75/4 i.e. 18.75</b>	30	
Theory Subject	Points obtained														
Sub-1	30														
Sub-2	27														
Sub-3	0														
Sub-4	18														
Average points scored	<b>75/4 i.e. 18.75</b>														
2	Research Publication 20 points average (1 sci indexed publication: 10 points, 1 publication having ISSN number : 5 points, Else ZERO)	20													
3	Faculty development programme 10 point average (one faculty development programme minimum 5 days attended 5 points, 2 points for attending 2 days workshop, subject to maximum of 10)	10													
4	International / National conference 10 points average ( 5 points for attending International, 3 points for attending National of repute, 2 points for National conference)	10													
5	Research grant average 20 points for having grant of more than 5 lakhs, if only project submitted to DST/other govt agency: 10 points, subject to maximum 20	20													
6	Patent 10 points/Product development / start-up 10 points	10													
7	New Skills / additional specialization / certification course	25													
8	Innovation in teaching learning, video lecture, online MOOCs, Online notes uploading, any other 20 points	20													
9	Technical activity organized 5 points	5													
10	Participation in social responsibility 5 points / activity subject to maximum of 10	10													
11	Institute level activity organized 5 points, participation 2 points subject to maximum of 5	5													
12	Any award received, session chair in conference, guest lecture, invited talk, etc. 5 points	5													
13	HOD recommendation maximum 30 points (Departmental responsibility 2 points, NBA related activity 5)	30													
<b>Total</b>		<b>200</b>													

Note: HOD will verify the documentary proof.

Signature of Faculty

Signature of HOD

[SELF ASSESSMENT REPORT]



Jaipur Engineering College & Research Centre

: OS Office

To : Mr. Shashak Shekhar Singh, ME

20<sup>th</sup> July 2018

Advisory Note

Shashak Shekhar Singh, AP  
Mechanical Engineering

Through Program Coordinator/HOD

per the faculty appraisal form submitted by you for the session 2017-18, you have secured total 89 points out of 200. You are hereby advised to improve your performance during the session 2018-19.

  
PRINCIPAL

Copy to -

1. Vice Chairman
2. Director
3. Concerned Program coordinator/HOD
4. Concerned faculty member
5. Personal File







**Corrective measures:**

- Explanation from the faculty will be demanded for the inappropriate result and subsequent action will be processed.
- Counseling will be given to the concerned faculty by HOD and Principal.
- Promoting and encouraging faculty to attend the faculty development programs (FDP), short term training programme (STTP), Conferences, MOOC'S, Guest lectures, industry visit.
- More emphasis is given to the performance of weak students.
- More emphasis is required towards the institute -industry interaction.

**Faculty Development Program**

Session: 2017-18	Session: 2016-17	Session: 2015-16
FDP on <b>Effective Mentoring Skills</b> (11-13 July 2017)	-----	-----
Short Term Course on <b>PRODUCT DESIGN &amp; DEVELOPMENT</b> By NITTTR, (6/11/2017-10/11/2017)	Short Term Course on <b>New Manufacturing Technology</b> by NITTTR, (7/11/2016-11/11/2016)	Short Term Course on <b>Sustainable Development Challenges &amp; Opportunities</b> by NITTTR, (12/10/2015-16/10/2015)
-----	-----	Short Term Course on <b>Recent Trend in Automobile Engineering</b> by NITTTR, (29/02/2016-04/03/2016)

**National and International Conferences**

S#	Name of conference	Date	Level of conference	Conference outcomes	Relevance to POs
1	NCFTME-2015	14-15 March 2015	National	Knowledge about the research, Innovations and future scope in Mechanical Engineering.	PO1, PO4, PO10, <b>PSO1</b> , <b>PSO2</b>
2	RESSD-2016	07-08 October 2016	National	Knowledge about the recent innovations in Mechanical Engineering.	PO1, PO4, PO10, <b>PSO1</b> , <b>PSO2</b>
3	RITDME-18	06-07 April 2018	International	To Enhance knowledge about recent innovation and research in Mechanical Engineering.	PO1, PO4, PO10, <b>PSO1</b> , <b>PSO2</b>



National Conference “Futuristic Trends In Mechanical Engineering”, held at JECRC, Jaipur, during 14-15 March 2015



National Conference “Renewable Energy Sources and Sustainable Development: Opportunities and Challenges”, held at JECRC, Jaipur, during 07-08 October 2016



Interational Conference “Recent Innovations and Technological Development in Mechanical Engineering”, held at JECRC, Jaipur, during 06-07 April 2018

**Indices used for measuring quality of teaching & learning and summary of the index values for all courses/teachers**

- Students Attendance Report
- MTT Results
- University Results
- Final Passing Percentages
- Placement Record
- Student’s performance in National and International conferences
- Student’s performance in Technical Workshops
- Student’s participation in Intra and Inter college competitions
- Co-curricular and Extra-curricular activities.

**MOU’s have been done with industries to emphasize on**

- (a) Internship
- (b) Project Workshop for Students
- (c) Industrial Visits
- (d) Students specific Training

Details of MOU

S. No.	Company Name	Date
1.	Forsk Technologies 	2-Nov-2017
2.	RedHat Technologies 	7-Nov-2017
3	Infosys Campus Connect 	12-May-2017
4	CADD Centre 	30-Oct-2017
5	Wadhvani Foundation 	13-Oct-2017
6	SakRobotix Lab 	27-Apr-2017
7	Salesforce Technologies Ltd. 	17-Jan-2018
8	Indo Vision Services Pvt. Ltd. 	22-Mar-2017
9	Cyber Security	May-2018

The following are the details of MOUs:

1. **ForskTechnologies:**Forsk Technology offer project based learning in IoT (Internet of Things) and Machine Learning (Data Science). Future courses will be offered

- based on industry requirement and/or student/faculty feedback. These future courses will be on emerging technologies.
2. **Red Hat Technologies Pvt. Ltd.:** Linux World ('LW') is a fast growing ISO 9001:2008 Certified Organization which is fully governed by young and energetic Technocrats, dedicated to Open Source technologies and Linux promotion. Since its inception in the year 2005, LW have achieved the status of centre of excellence wherein there is latest technology, innovative developing methodology, state of the art infrastructure and individual needs of employees are identified and executed professionally, efficiently & ethically.
  3. **Infosys Campus Connect:** Launched by Infosys in May 2004, CC is a unique academia-industry initiative to “architect the education experience”. The objective in launching the CC programme is to enhance the quality and quantity of the IT talent-pool; sustain the growth of the IT industry itself. The portal will provide a digital platform for academia-industry interaction anytime, and anywhere.
  4. **CADD Centre:** As Asia's biggest network of CAD training centers, CADD Centre Training Services is the training arm of the 30 year old CADD Centre Group, head quartered at Chennai, India. They being the only company in India to offer an end-to-end solution to CAD users specializes in Computer Aided Design (CAD), Computer Aided Engineering (CAE), and Computer Aided Manufacturing (CAM) with our wings spread across the globe.
  5. **WADHWANI Foundation:** Launched in 2000 by Dr. Romesh Wadhvani, the Foundations comprising of Wadhvani Charitable Foundation and Wadhvani Operating Foundation are working with the primary mission of accelerating economic development in emerging economies through large-scale job creation with presence in Asia, Africa and Latin America operating in association with governments, corporate, mentors, investors and educational institutes. Its Initiatives are driving job creation through entrepreneurship, skills development and innovation.
  6. **SAKROBOTICS LAB:** Establishing a Robotics Research Centre in the campus of JECRC, providing Internship to JECRC Students and to engage the students in Robotics Training and also offering Robotics product development exposure.



## [SELF ASSESSMENT REPORT]



### 9.3 Feedback on facilities (5)

S. No.	Facility	How feedback is taken	Type of Record	Action Taken
1	Hostel  Sh P. K. Gupta (CAO /Chief warden)	Entry in the register / discussion with warden / written application / Grievance cell	About Stay in the hostel	Sharing of room changed from 4 to 3
			About Food	Student committee and warden
			About Timing	Boys and girls timings are fixed but on demand as per requirement permission is provided.
			Maintenance	Entry in register and corrective action
			Medical Exigency	Ambulance register
2	Transport Sh. Ravi Bhatnagar (Bus Incharge)	Written application with Bus In charge	Route	Recorded with bus in charge and appropriate action is taken
			Fees	
			Flexibility / Maintenance of buses	
3	Library  Dr. Anita Jain (Chief Librarian)	Departments are taking feedback related to library and thus submitted to librarian	Timing	Appropriate action taken by Library incharge
			Books	
			Publication	
			E-books	
			Swayam	
4	Sports Dr. Rajesh Sharma (Sports Incharge)	Feedback taken by sports incharge	Ground	Sports incharge takes appropriation decision
			Participation	
5	Over all maintenance Sh. Yogendra Sharma	Feedback from Block Incharges	About maintenance & Safety	
6	Security Sh. P. K. Tiwari	Over all security	Meetings every month	Feedback in the meeting
7	Medical Facility	CAO is responsible	Files maintained	Medical OPD First aid

#### Cleanliness feedback:

#### Soch Initiative (Soch –Coordinator)

#### SWACHCHH JECRC

**SOCH-KUCHH KAR DIKHAANE KI**, keeping this motto in mind, the **Team Soch** of JECRC stepped an extra mile to realize the dream project of the H'ble Prime Minister Sh. Narendra Modi, **Swachhh Bharat Abhiyan**, by launching an innovative digitally enabled campaign **SWACHCHH JECRC**. This campaign was aimed to contributing to the society in terms of cleaning the JECRC campus through the QR code. This campaign changed the whole idea of cleanliness. Never did anyone think that cleanliness could be monitored digitally.

## [SELF ASSESSMENT REPORT]



In this campaign, a special QR code was designed by the technically advanced students of JECRC and put on the posters, dustbins, all over the campus, to expedite the cleanliness drive, which could be accessed through any smartphone, prompting to fill a google form for complaining against any negligence in cleanliness or giving any suggestions regarding the misplacement of the dustbins, areas not cleaned etc for example.

The following link can be used for filling the form:

<https://goo.gl/EAnOqd>

This google form contains many points, such as, College Area Map, Issues Related to Dustbins, Complaints Related to Cleanliness etc. A few screenshots are:

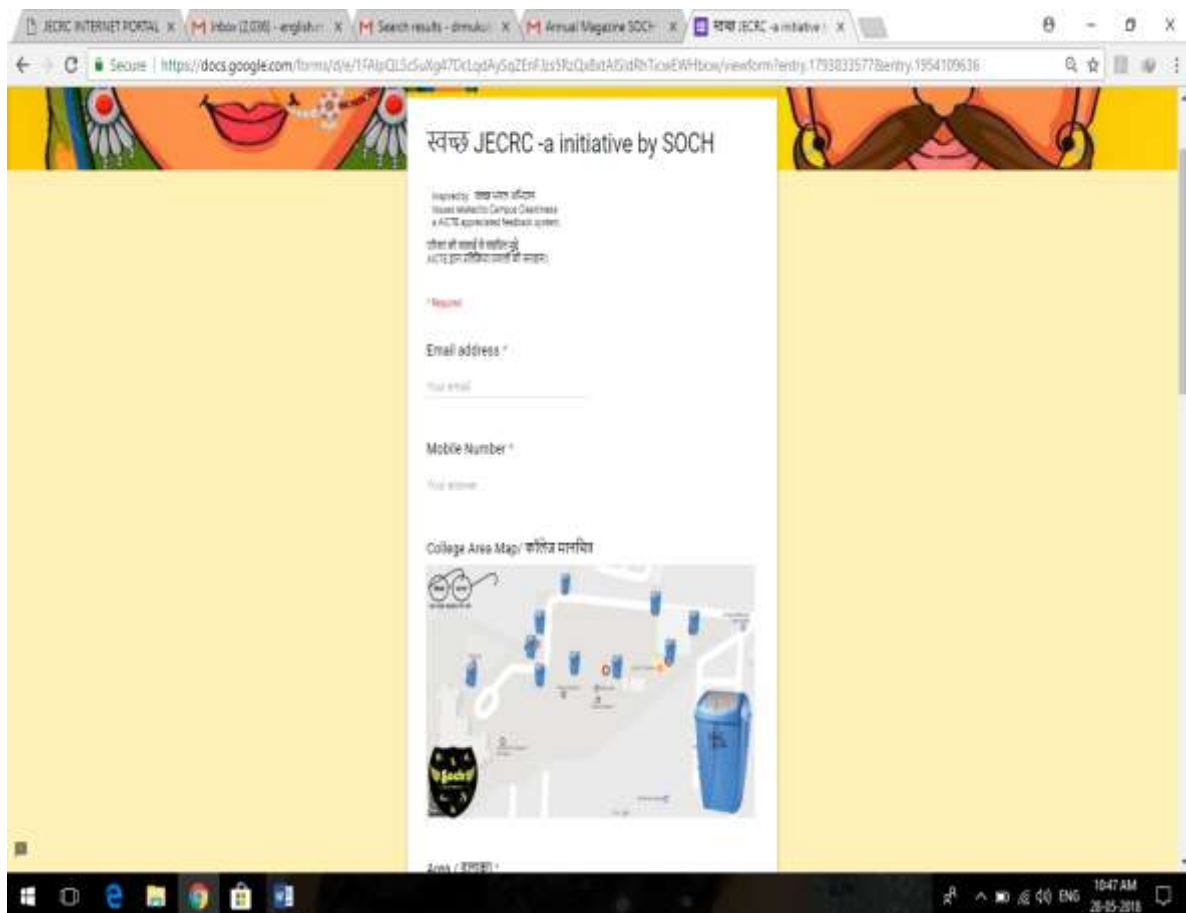

# [SELF ASSESSMENT REPORT]

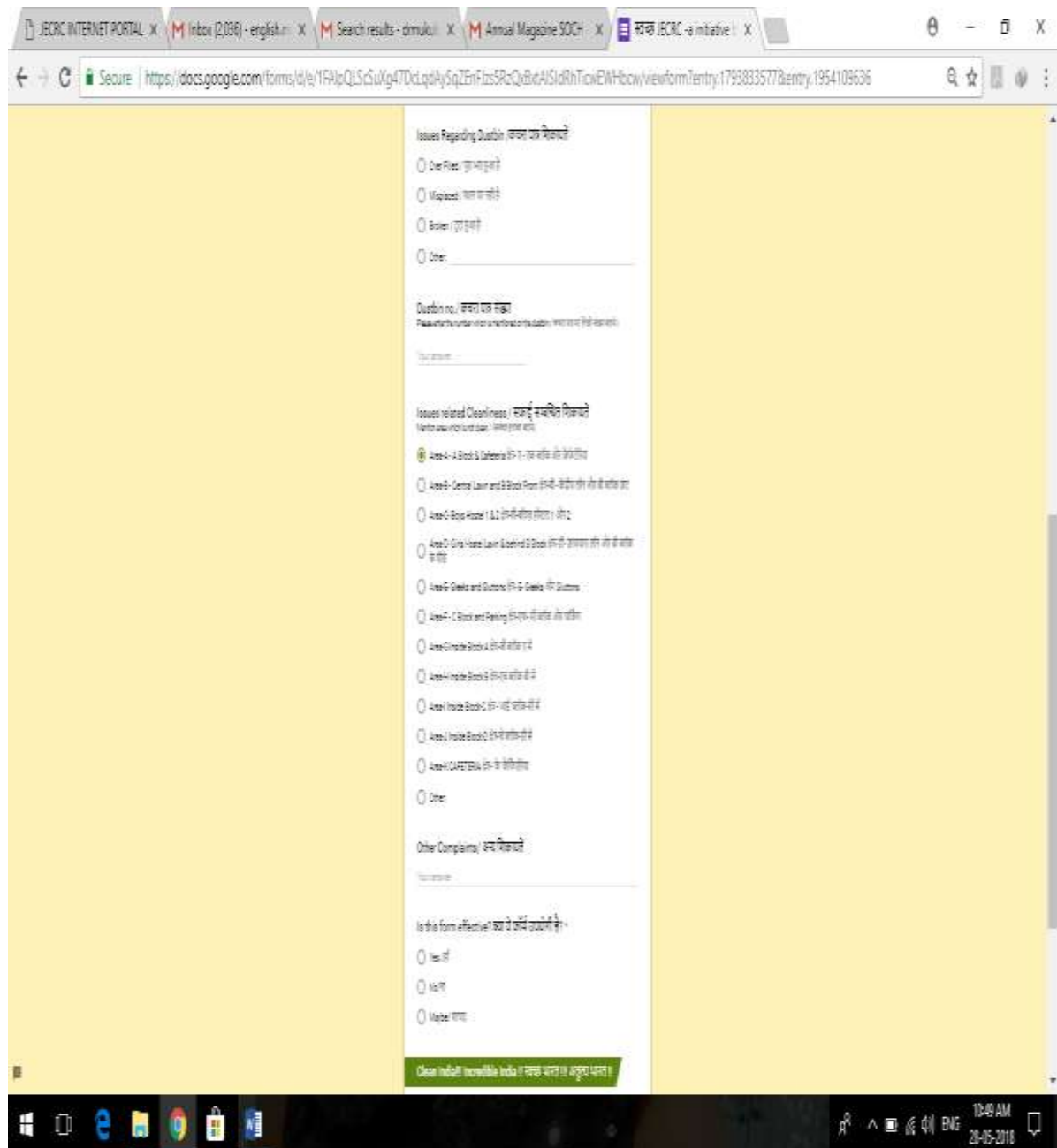

For any trash, smeared environment, a complaint can be filed by scanning the QR code. By scanning the QR code, a dialog box pops up on the screen which leads us directly to the complaint form. The data filled in the form reaches our supervisors and a response is given within 24 hours.

We get about 10 to 20 number of complaints every day and making it a count of 375 till date which is really astonishing.

In this changing era of digitalization, this innovative **SWACCH JECRC** campaign has done a great work.





- 15 days celebration took place as “Swacchata Pakhwada” in JECRC, students were participated in this activity, checked for clean campus.
- Students as well as faculties were involved to clean the campus and program continued for 15 days.



“Swacchata Pakhwada” celebrated, Cleanliness raised

#### 9.4. Self-Learning (5)

*(The institution needs to specify the facilities, materials and scope for self-learning / learning beyond syllabus, SWAYAM , NPTEL, MOOCs etc. and evaluate their effectiveness)*

Self-Learning method is an individualized method of learning collecting information, processing it, and retaining it without the needs for another individual to teach it. For self-learning or learning beyond syllabus during the semesters we provide information sharing material and orgnize different types of activities like workshop, training, conferences, club activities, quiz etc. For these activities academic calendar has sufficient provisions and HOD is authorized to change in schedule with permission of respective authorities.

#### I. Scope of Self – Learning

- Assignments
- Professional bodies
- Seminars
- Web based learning
- Library
- Industrial visits

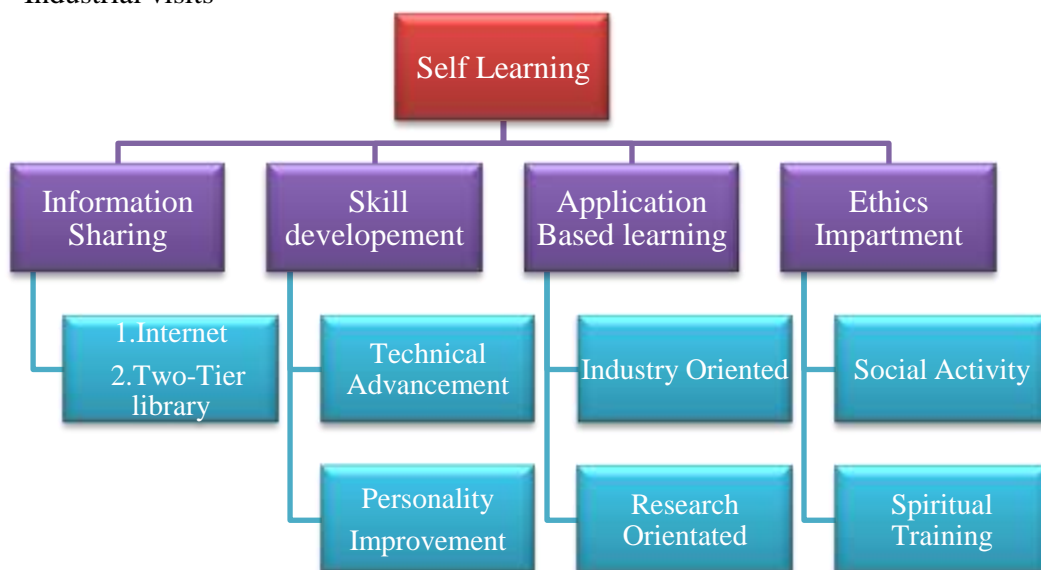

## [SELF ASSESSMENT REPORT]



### Availability of Facility, Materials and Scope for Learning

S.No.	Activities	Beneficiary	Details
1	2-tier Library System	Faculties & Students	The institute has the effective 2-tier Library System both at Institute and the departmental level. The library is facilitated with more than two thousand books and more than eight thousand e-books, GATE, CAT preparation material, NPTEL video for students.
2	Availability of Internet facility in All labs.	Faculties & Students	Our institute has dedicated 12 Mbps lease line with 100% uptime. The labs is equipped with internet facility and at any time internet can be made available in all the labs.
3	Moocs like Swayam	Faculties & Students	SWAYAM is a programme initiated by Government of India, the objective of this effort is to take the best teaching learning resources to all.
4	Personality Development lectures	VII	Creativity, lateral thinking and communication / people management skills are essential Components for progress in any sphere. Students are encouraged to develop these through goal setting exercises, group discussions, mock interviews and presentations.
5	Face classes	VII	Special classes conduct to improve Aptitude, Reasoning (Verbal and nonverbal), Soft skill and communication of students for placement purpose.
6	Industrial visit	V,VI	To bridge the gap between Industry and academia, various modules are covered.
7	Training program /Workshop/Seminars	All students	To enhance knowledge and develop technical skill.
8	Technical Events	All students	To enhance the technical knowledge.
9	International /national Conferences	Faculties & Students	For sharing new ideas and innovation common platform is provided.
10	FDP's	Faculty & Technical staff	Development of faculties.
11	Social activities: (A) Zarurat (B) Soch (C) Aashayein (D) Suhasini	All Students	All round development essentially means intellectual, physical, moral, sensible and social development.

## [SELF ASSESSMENT REPORT]



12	Spiritual Training	Faculties & Students	For help in increasing mental capacity to focus better
	<b>Assignments</b>	Students	It enabled students to go through the topics in a more elaborate manner in order to explore the academic topic which lead to an overall better learning experience for students. Assignments help the students to understand the subject in a more detailed pattern.

### No. of students crack competitive exams

Year	No. of Student appeared online exam	No. of Student (Passed)
2015-16	92	22
2016-17	84	22
2017-18	68	16

### Personlity Improvement

Year	Faculty	No of students enrolled
2015-2016	FACE Faculties	134
2016-2017	FACE Faculties	116
2017-2018	FACE Faculties	133

Year	Name of event	Object of event	No. of students participated	Date of event
2015-16	Pre Placement training Program by FACE	Bridging gap between academics & Industry	180	12-10-2015 To 14-10-2015
2016-17	Pre placement training by Face	<i>Bridging gap between academics &amp; Industry</i>	184	18-7-2016 To 6 -8-2016
2017-18	Pre placement training program by Face	Bridging gap between academics & Industry	186	20-7-2018 onwards

### Industrial Visits

#### Industrial visits Table:

Year	Location	Company Name	No of students enrolled
2015-2016	Ajmer	HMT	32
2016-2017	Jaipur	MANUYANTRALAYA	35
2017-2018	Jaipur	CIPET	40
	Jaipur	MSME	44
	Jaipur	RATAN ITI	50



Training detail table:

JAIPUR ENGINEERING COLLEGE & RESEARCH CENTRE, JAIPUR			
Department of Mechanical Engineering-Practical Training-2016-17			
R.No	Name of Students	Training Destination	Outcomes
1	Aadil Ahmed Farooqui	BOSCH Jaipur	D.Planning, Mantence
2	Abhimanyu Singh Bhati	Thermal Super Power Plant, Kota	Power Generation
3	Abhisek Bharadwaj	Tata Eicher Engine, Alwer	Manufacturing (Assembly)
4	Abhishek Swami	Super Thermal Power, Surat	Manufacturing
5	Aditya Agarwal	Reliance Industries LTD, Jamnagar	Design, Quality Control Maintenance
6	Akansh Agarwal	Ashok Leyland, Alwar	Maintenance, Manufacturing
7	Akash Garg	Dholpur Combined cycle Power Plant	Planning , Quality
8	Akash Jain	JIT Proccess ,Alwar	Machining Process
9	Akhil Kumar	Diesel Shed, Phulera	Maintenance
10	Akshat Tiwari	BOSCH Jaipur	First Pass Yield Imp/Quality
11	Akshay Bhardwaj	National Engineering Industries LTD, Jaipur	Manufacturing, Quality Control
12	Akshay Kirti Sharma	Minda Industries LTD	Manufacturing, Planning

## [SELF ASSESSMENT REPORT]



13	Akshay Kumar Soni	Ultratech Cement LTD	Planing , Quality, Control, Maintence
14	Aman Gupta	Ashok Leyland, Alwar	Maintance, Manufacturing
15	Aman Vyas	Nuclear Power Corporation of Indistries	Production of Obcevlty
16	Amit Modi	JIT Proccess ,Alwar	Machining Process
17	Aniket Sharma	JBM LTD, Gurgaon	Maintance, Manufacturing
18	Anish Jain	Heavy Water Plant, Kota	Heavy Power Production
19	Anjani Kumar Mundhara	Rajasthan Surico(P) LTD, Napaser	Manufaturing
20	Ankit Bhardwaj	NEI-NBC Beawar	Analysis of Bearing
21	Anshul Jain	Maruti Suzuki India Ltd. Gurgaon	Design, Quality Maintence
22	Anshul Khandelwal	KEC Int. Ltd, Jaipur	Production Process
23	Anshuman Sisodia	Shree Cements, Beawar	Planing, Manufacturing, Manitance
24	Anuj Bhandari	Hindustan Zinc Ltd, Dariba	Process, Project
25	Anuj Tiwari	Indian Railway, Ajmer	Maintence, POH
26	Anurag Verma	BOSCH Jaipur	Planning, Market
27	Arnim Vijay	INA Bearings India (Schaeffles Group)	Discupinary Actions
28	Arun Yadav	Maruti Suzuki India Ltd.	Chance the theory Kbowlege
29	Ashesh Bansal	Dholpur Combined cycle Power Plant	Get,Production, Power Gereneration
30	Ashish Kumar Choudhary	Hindustan Copper LTD, Khetri	Manufacturing
31	Ashutosh Kumar	Riw Auto Industuies, dharuhera	Manufacturing
32	Ashwini Kumar Tripathi	Diesel Locomotice Works	Manufacturing
33	Asutosh Jain	HEC NPCIL	Design, Maintence, Power Generation
34	Atul Chaudhary	Ashok Leyland, Alwar	Front and Real acle and chasis assembly
35	Avadhesh Kumar Sharma	Ashok Leyland, Alwar	Front and Real acle and chasis assembly
36	Ayan Dutta	Tata Technologiyes, Pune	Topograhoy
37	Ayush Khandelwal	Tata Eicher Engine, Alwer	Assembly Department
38	Bhanu Pratap Singh	Diesel Shed, Phulera	Maintence
39	Chetan Prakash Saini	TMTL Eicher Engines LTD	Assembly Line
40	Deepanshu Sharma	Ashok Leyland, Alwar	Assembly

## [SELF ASSESSMENT REPORT]



41	Deepender Singh Rathore	Diesel Shed, Phulera	Maintence
42	Dharmesh Kumar Sharma	KEC, Jaipur	Fabriation
43	Dheeraj Agarwal	Ashok Leyland, Alwar	Working of hydrolic pumps
44	Divyansh Bhatnagar	IIT Guwahati, Guwahati	Eco Friendly cutting & wids
45	Ekant Singh	HEC, Ranchi, Eicher	Planning, Manufacturing
46	Gajendra Kumar Teli	KEC, Jhotwara, Jaipur	Galavanizing
47	Ganesh Kumar Sah	NET, Jhotwara, Jaipur	Manufacturing
48	Gaurav Gadodia	NET, Jhotwara, Jaipur	Manufacturing
49	Gaurav Prajapati	NTPC, AntarBaran(Raj)	Study of Turbine
50	Gaurav Sahu	KEC Int. Ltd	Galavanizing Department
51	Harsh Agarwal	Ashok Leyland, Lt	Manufacturing and Quality Control
52	Harsh Yadav	North western Railways, Bikaner	Fabrication
53	Harshita Garg	GAIL Ajmer	Estimated Repair Factor
54	Harshvardhan Arya	Bosch Ltd, Jaipur	Desigh and maintainance
55	Hemant Kumar Patidar	Kalisindh Thermal Power Plant	Design & Function
56	Himanshu Nagar	Chhabra Thermal power plant	Power generation
57	Himanshu Sharma	Bosch India Ltd. Jaipur Plant	Design and rootcause finding
58	Jitendra Choudhary	JIT Processors	Manufacturing
59	Jitendra Kumar Sain	HMT ajmer	Casting
60	Kapil Sharma	JIT Proccersors	Manufacturing
61	Keshav Goyal	HMT	Manufacturing
62	Lekhraj Gakkhar	Ashok Leyland Ltd.	chassic Assembly
63	Lokesh	Honda cars india limited	Quality control
64	Manish Arora	KEC International Ltd.	Galvanizing Deptt
65	Mohit Yadav	Eicher engines LTD	Assembly line
66	Mragank Ohja	Bosch Jap	Plant Quality Automasive
67	Mridul Agrawal	HMT, Ajmer	Manufacturing & Assembly
68	Mukesh Kumar	KEC International Ltd.	Galvanising deptt
69	Mushtafa Kohri	North western Railways	Maintanance
70	Naman Jain	HMT	Manufacturing
71	Namit Kumar Tiwari	NBC Jaipur	Manufacturing & Assembly

## [SELF ASSESSMENT REPORT]



72	Namit Misra	NIBC bolpur, NBC Jaipur	Manufacturing
73	Naveen Kumar Sahu	Bharat Buagon Company LTD, Bihar	Manufacturing, Assembly
74	Nishant Bhargava	National Engnieering Industries LTD, Jaipur	Manufacturing
75	Parth Mittal	Adani Thermal Power Rajathan	Power Production
76	Pawan Kanoongo	National Engnieering Industries LTD, Jaipur	Manufacturing
77	Pawan Kumar	Bosch Ltd,Jaipur	Maintanance
78	Prabal Kumar Jain	Shree Cements, Beawar	Welding and
79	Prakash Chandra Jyani	Aarmom Tech. Pv.T	Designing and Inspection
80	Prakash Patel	Aarmom Tech. Pv.T	Designing and Inspection
81	Pramod Kumar	Bharat Wagon And Engg. Ltd	Manufacturing
82	Prateek Mittal	Tera Reseach Institute ltd	Manufacturing
83	Rahul Bhatnagar	ADRDE, Agra	Welding
84	Rahul Mangal	Sumrise Containers LTD	Manufacturing
86	Rajchander Jain	KEC LTD, Jaipur	Fabrication
87	Ramnik Kaul	ROCA Bathroom Produit Pvt. LTD	Bathroom Maintacnce
88	Raunak Sharma	National Engnieering Industries LTD, Jaipur	Manufacturing
89	Raushan Kumar	Bharat Wagon And Engg. Ltd	Practical field work
90	Rifatullah Khan	Hindusthan Zine LTD	Maintanance
91	Rishabh Gupta	Maruti Suzuki LTD	Quality control
92	Rohan Jain	ROCA Bathroom Produit Pvt. LTD	Bathroom Maintacnce
93	Rohit Kumar	National Engnieering Industries LTD, Jaipur	Production Process
94	Rohit Mehta	Satyam Auto Component Pvt. LTD	Quality control
95	Ronak Jain	Action Construcation Equipment ltd	Assembly, Design, Quality Control
96	Sachin Parashar	Yamaha Indiiia Moter Pvt. LTD	Manufacturing
97	Samoli Kumar	Bharat Wagon And Engg. Ltd	Production and Manufacturing
98	Santosh Kumar	Bharat Wagon And Engg. Ltd	Production and Manufacturing
99	Sanwar Lal Gurjar	HMT,Ajmer	Manufacturing, Assembly
100	Saransh Hari	Vita Cera Services LTD	Android Based Apliaction
101	Satya Prabhat	Premium Molding and Pressing	Production
102	Saurabh Kumar Singh	Yamaha Indiiia Moter Pvt. LTD	Manufacturing
103	Sawan Agarwal	Ajmer Diesel and Locomotive	Inspection and Maintacnce
104	Shashi Kumar	Bharat Wagon And Engg. Ltd	Inspection



## [SELF ASSESSMENT REPORT]



105	Shubham Goyal	NEI, Jaipur	Manufacturing
106	Shubham Gupta	NEI, Jaipur	Manufacturing
107	Shubham Sharma	Larson and Turbo	Production
108	Sourabh Gupta	NTPC, AntarBaran(Raj)	Study of Turbine
109	Sudhir Kumar	KEC, Jaipur	Tubrication
110	Sumit Kumar Pachouri	Mahindra and Mahindra Tractors	Lubrication and Assembling
111	Surender	Jindal Station steel, Hisar	Manufacturing
112	Surendra Joshi	Jaypee Sidhi Cement M.P	Manufacturing
113	Vinayak Gaur	North Western Railway Bikaner	Maintanance
114	Vishal Yadav	North Western Railway Bikaner	Maintanance
115	Vishwas Singh	Minda Industries LTD	Manufacturing
116	Yashwant Kumar Nama	NEI (NBC)	Manufacturing
117	Dushyant Pareek	Bosch Ltd, Jaipur	Maintanance
118	Naresh Saini	National Engnieering Industries LTD, Jaipur	Manufacturing
119	Yashasvi Bareth	Rajasthan Roadways	Observation And Learning
120	Hitesh Chouhan	Loco and Diesel Workshop Ajmer	Maintanance
121	Prakash Udeniya	Loco and Diesel Workshop Ajmer	Maintanance
122	Deepak Kumar	Coach Care Complex Jaipur	Maintanance
123	Wasim Akhtar	IOCL, Barauni Bihar	Maintanance (Workshop)
124	Vikash Kumar Sinha	IOCL, Barauni Bihar	Maintanance (Workshop)
125	Dhanraj	NWR Carriage and Wagon Workshop ajmer	POH
126	Nitish Kumar	IOCL, Barauni Bihar	Maintanance (Workshop)
127	Jasvinder Singh	KECIL, Jaipur	Fabrication
128	Prakhar Agrawal	NEI JAIPUR	Manufacturing
129	Shivam Gandhi	Loco and Wagon Workshop Ajmer	Maintanance
130	Gaurav Gupta	Eicher engines LTD	Maintanance
131	Garvit Jain	BHEL Bhopal	Manufacturing
132	Santosh Rawat	NEI JAIPUR	Manufacturing
133	Shubham Gupta	NTPC, AntarBaran(Raj)	Study of Turbine
134	Aaditya Bishnoi	Swaraj Mahindra Mohali	Mainitence, Assembly, Creating Sops
135	Ashish Sharma	Climatech Aircon eng. Pvt. LTD	Installation , Service
136	Chetan Prajapati	Climatech Aircon eng. Pvt. LTD	Installation , Service

## [SELF ASSESSMENT REPORT]



137	Daljeet Singh	KEC, Ltd, Jaipur	Fabrication, Maintenance
138	Devesh Chundawat	Morani Hyundeii	Maintanance
139	Harish	Suratgarh Thermal Power Plant	Power generation
140	Irphan Khan Pathan	Rajasthan Agro Industrial Ltd	Assembling
141	Mrinal Pandya	J.K Tyres & Industrial LTD	Manufactring, Maintanance
142	Pavan Kumar Sharma	Jindal Station steel, Hisar	Manufactring
143	Pramod Kumar	Jindal Station steel, Hisar	Manufactring
144	Rahul Aswal	NBC (NEI)	Manufactring
145	Rakshit Trivedi	RSHM Thermal Power Plant	Power generation
146	Shailendar Patidar	NBC (NEI)	Manufactring
147	Shubham Arora	NWR Carriage and Wagon Workshop ajmer	POH
148	Sourabh Dashora	Ashok Leyland Pvt. LTD Utrakhand	Testing of Engine
149	Subham Vaishnav	Clenatech Aircen Eng. Pvt. LTD	Installation , Service

### JAIPUR ENGINEERING COLLEGE & RESEARCH CENTRE, JAIPUR

#### Department of Mechanical Engineering-Practical Training-2017-18

R.No.	Name of Students	Training Destination	Outcomes
1	Aditya Malik	Nissan, Soft Design	Design
2	Aishwerya Johari	Loco Diesel And Wagon Workshop N.W.R.	Maintenance
3	Akhil Singhal	Cimmco Ltd.	Planning And Manufacturing
4	Akshay Chaturvedi	Carriage Railway	Maintenance
5	Akshay Galav	K.S.T.P.S	Steam Turbine
6	Anirudh Jain	Honda	Ferrous
7	Anirudh Kumar Jain	Jpr Rlway Shree Cement	Manufactring
8	Ankit Malav	K.S.T.P.S	Steam Turbine
9	Ankur Goyal	Shree Cement	Maintenance
10	Anmol Rajawat	NEI Jaipur	Ball Bearing
11	Anshul Jain	Chhabra Thermal Power	Thermal Division
12	Anuj Yadav	NEI Jaipur	Ball Bearing
13	Anurag Bansal	Coachcare Complex	Maintenance

## [SELF ASSESSMENT REPORT]



14	Arpit Agarwal	Bosch,Bangluru	Automobile Technology
15	Arpit Akar	Indian Railways	Maintenance
16	Arpit Gupta	BOSCH Ltd.	Automobile Technology
17	Arpit Natani	Rapp Rawatbhata	Maintenance
18	Arpit Sharma	K.S.T.P.S	Steam Turbine
19	Ashish Kumar	K.S.T.P.S	Steam Turbine
20	Ashish Kumar Gupta	Railway Kota	Maintenance
21	Ashok Sinwar	Bosch, Ajmer Railway	Maintenance
22	Ashutosh Dhyani	Gmax Auto Limited	Mold Assembly
23	Ayush Kumar Gupta	Jaipur Railways	Loco
24	Bharat Agarwal	NEI Jaipur	Manufacturing
25	Bhudev Prasad Sharma	K.S.T.P.S	Power Generation
26	Chandra Mohan Sharma	FEV Pune, India	Mechanical Setup
27	Chandra Pratap	NTPC Dadri	Power Generation
28	Chirag Solanki	FEV Pune, India	Project Management
29	Deepesh Mittal	JBM, Gurugram	Quality Assurance
30	Devesh Purohit	NEI Jaipur	Maintenance
31	Dhruv Khandelwal	NEI Jaipur	Manufacturing
32	Dhruv Laddha	Wonder Cement	Mechanical
33	Dilip Jajoo	B.M. Techno Machines	Mfg. Dept.
34	Dinesh Kumar Jain	Ajmer Railway,JBM Group Gurgaon	Maintenance
35	Dushyant Jha	Ashok Leyland	Chassis Assembly
36	Gagan Kumar Jindal	Denso India Pvt. Ltd.	Assembly Line
37	Gaurav Pareek	NEI	Tapper Bearing Assembly
38	Gaurav Vaishnav	NEI Jaipur	Tapper Bearing Assembly
39	Govind Kumar Poddar	Bharat Wagon	Manufacturing
40	Govind Vyas	Mahindra And Mhindra	Aintenance Process In Assembly Line
41	Harichand Goswami	DCCPS	Power Generation
42	Himanshu Guneshwar	Ashok Leyand	Spqa
43	Himanshu Paliwal	K.S.T.P.S	Power Generation
44	Himanshu Rai	DLW	General Department
45	Hitesh Arora	Honda	Ferrous
46	Jai Kishan Soni	Sksup Ltd.	Manufactring

## [SELF ASSESSMENT REPORT]



47	Javed Khan	K.S.T.P.S	Power Generation
48	Jitesh Kumar	DCCPS	Power Generation
49	Kalpesh Patidar	R V U N L	Power Generation
50	Kana Ram Nitharwal	JCB	Installation of Salt Conveyor
51	Kapil Tejwani	NEI Jaipur	Maintenance
52	Keshav Gandhi	Diesel Loco And Wagon Workshop,	Maintenance
53	Khushal Patodia	Eicher Engines	Maintenance
54	Kuldeep Kushwah	Loco and Waon Workshop Ajmer	Maintenance
55	Kuldeep Saini	NBI Jaipur	Maintenance
56	Lakshya Joshi	Hindustan Aeronautics Ltd	Mfg. Dept.
57	Lilleshwar Singh Rawat	MP Birla Cement	Production
58	Lincoln Gori	BARC,Eicher	Reactor Safety Division,Engineering
59	Mahak Bhatt	K.S.T.P.S	Power Generation
60	Mahak Goyal	Shree Cement	Manufacturing
61	Mayank Sharma	Land T	Automation
62	Md Quamre Alam	IOCL	Mechanical Department
63	Mohit Saini	Danish Pvt Ltd	Manufacturing
64	Mudit Garg	FEV Pune, India	Mechanical Setup
65	Navneet Kumar	IOCL	Mechanical Department
66	Nayan Singh	NEI Jaipur	Maintenance
67	Neel Mehta	IOCL	Mechanical Department
68	Nitin Soni	NEI (Nei)	Maintenance
69	Om Prakash Yadav	Pradeep Transcore Pvt.	Production
70	Pallav Pandey	K.S.T.P.S	Power Generation
71	Piyush Kataria	Force Motors	Automobile Workshop
72	Prashant Prajapati	Nwr, Coach Care Complex	Bogie Maintenance
73	Rachit Sharma	Eicher, Alwar	Maintenance
74	Raghuveer Singh Hada	KSTPS	Production
75	Rahul Gahlot	Dunac Tata Motors	Inventory
76	Rahul Gupta	Eicher, Alwar	Maintenance
77	Rahul Gupta	Birla Cimmco	Maintenance
78	Ram Kumar Prajapati	NWR ABR	Maintenance

## [SELF ASSESSMENT REPORT]



79	Rishabh Bhardwaj	Ginni	Production
80	Rohit Kumar	NWR ABR	Maintenance
81	Ronak Jain	Force Motors	Service
82	Sandeep Singh	NWR ABR	Maintenance
83	Santosh Sharma	NWR ABR	Maintenance
84	Satya Prakash Arya	FEV India	Laboratory
85	Satyam Jain	Caparo Maruti	Production
86	Saurabh Mangal	Shree Cement	Production
87	Shahjade Alam	DMRC	Am/Rs
88	Shashank Bhandari	Wonder Cement	Production
89	Shivam Gupta	Kota Super Thermal Power Station	Coal Handling
90	Shivoham Shrivastava	NEI,Jaipur	Maintenance
91	Shobhit Yadav	Eicher Engines	Maintenance
92	Shubham Garg	Shriram Piston & Rings Ltd. Bhiwadi	Production
93	Shubham Heda	Shree Cement	Production And Maintenance
94	Shubham Jain	Eicher Engines	Maintenance
95	Shubham Khandelwal	NEI Ltd	Manufacturing
96	Shubham Rathi	RGTPP	Production
97	Shubham Shukla	Mahi Hydel Power Station	Maintenance
98	Subham Choudhary	Shree Cement	Manufacturing
99	Sudama Kumar	NEI	Production
100	Sumit Khurana	NEI,Jaipur	Production
101	Sunil Kumar Verma	NWR Abr	Maintenance
102	Suresh Choudhary	HRHE	Manufacturing
103	Tusshar Joshi	Mahi Hydel Power Station	Maintenance
104	Vaibhav Kumar Garg	Kota Super Thermal Power Station	Coal Handling
105	Vaibhav Vyas	HRHE	Manufacturing
106	Varun Agarwal	JBM	Quality
107	Vedant Singhal	Kota Super Thermal Power Station	Production
108	Vidyabhushan Kumar	Bosch	Training Centre
109	Vijesh Kumar Darji	Baba Automobile	Training Centre
110	Vinod Kumar Patel	IOCL	Maintenance
111	Vishal Kumar Bansal	Kota Super Thermal Power Station	Production

## [SELF ASSESSMENT REPORT]



112	Vishal Sharma	Shriram Piston & Rings Ltd.	Production
113	Vishvender Kumar	Manufacturing Processes Of Ball Bearing	Manufacturing
114	Vishvendra Singh	DCCPP	Maintenance
115	Vivek Sharma	Tata Motors	Service
116	Vivek Soni	NEI	Taper Roller Beareing
117	Yash Kumar Gupta	NEI	Ball Department
118	Yash Verma	NEI,Jaipur	Production
119	Yatendra Singh Tanwar	CADD Center	Product Design
120	Akshay Darshan Singh	CADD Center	Product Design
121	Vaibhav Mishra	Delta Star Rewari	Production
122	Shubhank Sharma	L&T Vadodra	Designing
123	Saurashtra Kumar	Bosch	Training Centre
124	Akhil Kuldeep	Rajasthan Atomic Power Station	Nuclear Training Centre
125	Abhishek Kumar	Bharat Wagon & Engg. Ltd	Manufacturing
126	Aijaj Khan	Jaipur Dairy	Production
127	Akshay Pal	NTPC	Power Production
128	Anish Joseph	Vikram Cement	Production
129	Ankit Meena	KSTPC	Production
130	Ankur Kumar Pareek	Shree Cement	Production
131	Girish Khandelwal	Eicher Engines	Testing
132	Gurjar Shrawan Kumar Jasvantbhai	Jaipur Dairy	Production
133	Hemraj Jangir	Tata Motors	Srevice
134	Himanshu Dubey	Apollo Tyre	Manufacturing
135	Jitendra Sharma	Cummins Service Center	Maintenance
136	Nirankar Singh	NEI	Production
137	Pushpendra Kumar Jangid	Jaipur Dairy	Production
138	Raushan Kumar	Bharat Wagon & Engg. Ltd	Production
139	Sagir Ahmad	New Swadeshi Sugar Mill	Production
140	Samaksh Jha	Tata Motors	Maintenance
141	Satveer	Suratgarh Thermal Power Plant	Production
142	Shivam Rawat	Jaipur Dairy	Production
143	Vijay Kumar Sharma	Maruti Suzuki	Maintenance
144	Dhananjay Ku. Yadav	Apollo Tyre	Manufacturing
145	Yash Sharma	Shree Cement	Power Production

## [SELF ASSESSMENT REPORT]



### Technical Event:

S. No.	Name of technical event	Level of event	Date	Outcomes	Relevance to POs
1	Embryo	National	18/02/2016	Student will be able to present paper and improve their communication skill.	PO1,PO4,PO10, <b>PSO1, PSO2</b>
2	Mightly Throttle	National	18/02/2016	Student will be able to enhance their knowledge of design of racing car.	PO1,PO3,PO5,P O9, <b>PSO1</b>
3	Propello	National	18/02/2016	Student will be able to know basic concept propulsion.	PO1,PO3,PO9
4	Cut 2 Design	National	19/02/2016	Student will be able to apply concept of Engineering drawing.	PO1,PO3
5	Fork Lifter	National	19/02/2016	Student will be able to build a crane model using wooden material suitable enough to place the given weights on a platform using only hydraulic mechanism.	PO1,PO3,PO9, <b>PSO2</b>
6	Brain quest	National	19/02/2016	Student will be able to improve their technical and general knowledge.	PO1
7	R-mecholympiad	National	20/02/2016	Student will be able to improve their core technical subject's knowledge.	PO1
8	CADD mania	National	20/02/2016	Student will be able to improve their designing skill.	PO1,PO5, <b>PSO2</b>
9	Reverse Engineering	National	20/02/2016	Student will be able to enhance their knowledge of engine parts.	PO1,PO3,PO9



Technical Event: **EMBRYO**

Description: **Paper Presentation**

Date: **8/03/2017**



Technical Event: **REVERESE ENGINEERING**

Description: **Assembling and Disassembling of Engine**

Date: **9/03/2017**





Technical Event: **MIGHTY THROTTLE**

Description: **RC Car Event**

Date: **10/03/2017**



Technical Event: **FORK LIFTER**

Description: **Hydraulic Crane Event**

Date: **11/03/2017**



Technical Event: **PROPELLO**

Description: **Hydraulic Rocket Event**

Date: **11/03/2017**



Technical Event: **R-MECH OLYMPIAD**

Description: **Technical Knowledge Event**

Date: **10/03/2017**



Technical Event: **BRAINQUEST**

Description: **Technical Knowledge Event**

Date: **9/03/2017**



Technical Event: **EMBRYO**

Description: **Paper Presentation**

Date: **8/03/2017**

## [SELF ASSESSMENT REPORT]



S.No.	Name of technical event	Level of event	Date	Outcomes	Relevance to POs
1	Embryo	National	20/02/2017	Student will be able to present paper and improve their communication skill.	PO1,PO4,PO10, <b>PSO1, PSO2</b>
2	Mightly Throttle	National	20/02/2017	Student will be able to enhance their knowledge of design of racing car.	PO1,PO3,PO5,PO9, <b>PSO1</b>
3	Propello	National	20/02/2017	Student will be able to know basic concept propulsion.	PO1,PO3,PO9,
4	Cut 2 Design	National	21/02/2017	Student will be able to apply concept of Engineering drawing.	PO1,PO3
5	Fork Lifter	National	21/02/2017	Student will be able to build a crane model using wooden material suitable enough to place the given weights on a platform using only hydraulic mechanism.	PO1,PO3,PO9, <b>PSO1</b>
6	Brain quest	National	22/02/2017	Student will be able to improve their technical and general knowledge.	PO1
7	R-mecholympiad	National	22/02/2017	Student will be able to improve their core technical subject's knowledge.	PO1
8	CADD mania	National	22/02/2017	Student will be able to improve their designing skill.	PO1,PO5, <b>PSO2</b>
9	Reverse Engineering	National	23/02/2017	Student will be able to enhance their knowledge of engine parts.	PO1,PO3,PO9



Technical Event: **CADDMANIA**

Description: **AUTO-CAD Event**

Date: **25-03-2018**

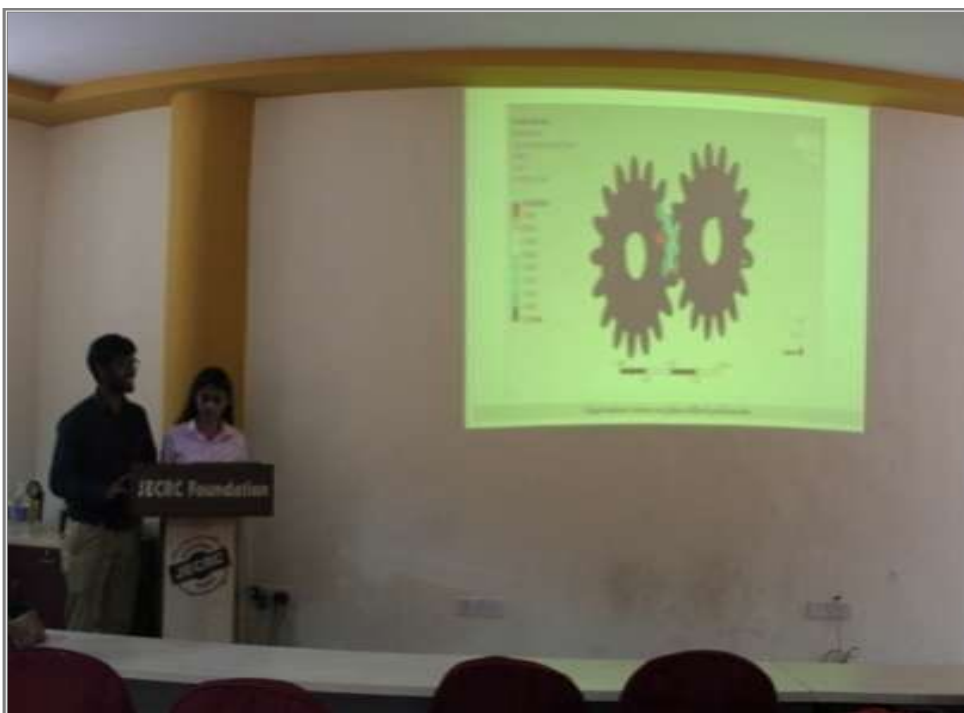

Technical Event: **EMBRYO**

Description: **Paper Presentation**

Date: **25-03-2018 & 26-03-2018**



Technical Event: **MIGHTY THROTTLE**

Description: **RC Car Event**

Date: **26-03-2018**



Technical Event: **BRAINQUEST**

Description: **Technical Knowledge Event**

Date: **26-03-2018**



Technical Event: **CUT-2-DESIGN**

Description: **Engineering Drawings Skills Event**

Date: **27-03-2018**



Technical Event: **R-MECH OLYMPIAD**

Description: **Technical Knowledge Event**

Date: **27-03-2018**



Technical Event: **FORK LIFTER**

Description: **Hydraulic Crane Event**

Date: **28-03-2018**



Technical Event: **PROPELLO**

Description: **Hydraulic Rocket Event**

Date: **28-03-2018**



## [SELF ASSESSMENT REPORT]



S.No.	Name of technical event	Level of event	Date	Outcomes	Relevance to POs
1	Embryo	National	21/02/2018	Student will be able to present paper and improve their communication skill.	PO1,PO4,PO10, <b>PSO1, PSO2</b>
2	Mightly Throttle	National	22/02/2018	Student will be able to enhance their knowledge of design of racing car.	PO1,PO3,PO5,PO9, <b>PSO1</b>
3	Propello	National	22/02/2018	Student will be able to know basic concept propulsion.	PO1,PO3,PO9
4	Cut 2 Design	National	22/02/2018	Student will be able to apply concept of Engineering drawing.	PO1,PO3
5	Fork Lifter	National	23/02/2018	Student will be able to build a crane model using wooden material suitable enough to place the given weights on a platform using only hydraulic mechanism.	PO1,PO3,PO9, <b>PSO1</b>
6	Brain quest	National	23/02/2018	Student will be able to improve their technical and general knowledge.	PO1
7	R-mech olympiad	National	23/02/2018	Student will be able to improve their core technical subject's knowledge.	PO1
8	Cadd mania	National	23/02/2018	Student will be able to improve their designing skill.	PO1,PO5, <b>PSO2</b>

### Conferences:

S#	Name of conference	Date	Level of conference	Conference outcomes	Relevance to POs
1	NCFTME-2015	14-15 March 2015	National	Knowledge about the research, innovations and future scope in Mechanical Engineering.	PO1, PO4, PO10, <b>PSO1, PSO2</b>
2	RESSD-2016	07-08 October 2016	National	Knowledge about the recent innovations in Mechanical Engineering.	PO1, PO4, PO10, <b>PSO1, PSO2</b>
3	RITDME-18	06-07 April 2018	International	To Enhance knowledge about recent innovation and research in Mechanical Engineering.	PO1, PO4, PO10, <b>PSO1, PSO2</b>



National Conference “Futuristic Trends In Mechanical Engineering”, held at JECRC, Jaipur, during 14-15 March 2015



National Conference “Renewable Energy Sources and Sustainable Development: Opportunities and Challenges”, held at JECRC, Jaipur, during 07-08 October 2016



Interational Conference “Recent Innovations and Technological Development in Mechanical Engineering”, held at JECRC, Jaipur, during 06-07 April 2018

- Conferences are the great way to learn about research and development going on in respective fields. Which inspired many students to publish their own research.
- It is also a great starting point for those students who want to pursue their career in research fields.

**List of publications by students:**

S.No.	Academic Year	No of Publications by Students in Journals	No of Publications by Students in Conference
1	2017-18	N/A	39
2	2016-17	16	26

**Utilization and its effectiveness:**

- The overall aim of this review is to evaluate the effectiveness of self-directed learning on the professional development of students.
- Most of the students reached to a conclusion that self-learning process is an effective approach for learning but not more than the traditional method of teaching.
- Students are motivated to improve their initiation in reaching their goals.
- Students are able to scan through the reading material available to them.
- Many of the needs of students are best met by learning process. The students are encouraged to learn by themselves for their present and future needs.
- Students are able to do better in competitive examinations and get placed in suitable companies.

**9.5 Career Guidance, Training, Placement (10)**

*(The institution may specify the facility, its management and its effectiveness for career guidance including counseling for higher studies, campus placement support, industry interaction for training/internship/placements, etc.)*

**Professional Guidance:**

We provide opportunities to students to improve placement percentage like interactions with MNC, Exhibition to provide internship.

S.No.	Name of Event	Date	Description
1	Placement Guidance Organized by HRD	August 2016	The event was graced by Mr. Sanjeev Khosla, MD, Accenture & Mrs. Shobha Kariappa, VP, Recruitment.
2	ISRO Exhibition	April 2016	For the first time in Rajasthan an exhibition of the “Space Endeavors of India” was conducted by ISRO (Indian Space Research Organization) at JECRC University in April 2016.
3	Awareness Workshop (SIH 2K18)	January 2018	Workshop about second edition of smart india hackathon
4	JECRC Hackathon	10 <sup>th</sup> January 2018 And 11 <sup>th</sup> January 2018	200 students teams participated in a 24 hour nonstop digital product development competition
5	Interactive Session		Mr. Ranjit Sinha, Head, GSC India and Ms. Sakshi Mehta, Head, Sustainability
6	Careers in Entertainment industry (“masale Pyar Vaale”)	2018	Held a screening of a short film “masale Pyar Vaale” of New York Film Academy.
7	Exhibition Organized by ISRO.	April 2018	Space Endeavours of India was conducted by ISRO
8	Interactive Session Organized by Sanjev Ohri	September 2017	This session conducted by Dr. Sanjeev Ohri, Uk.
9	Interactive Session SPIC MACAY	September 2017	Conducted by Dr. Kiran Seth, founder, SPIC MACAY
10	SIH 2K18 Organized by MHRD, Govt of India	30 <sup>th</sup> -31 <sup>st</sup> March 2018	JECRC was among the only twenty eight colleges selected in the country.



ISRO Exhibition 2016



ISRO Exhibition 2018



Interactive Session with Mr. Sanjeev Ohri and Mr. Nikko Philips



Smart India Hackathon 2K17



JECRC Hackathon 1.0



SIH 2K18 Awareness Camp



Smart India Hackathon 2K18

**Campus Placement Support/Training:**

A training and placement cell is established and responsible for campus placement (off campus also) and training which improve students skills both technical and behavioral. A cell provides various opportunities for student placements and organizes sessions / training programs.

1	Interactive Session (TCS Commune Program)	2017	The talent acquisition head, North India for TCS, Mr. Narendra Chandel visited JECRC to interact with students regarding the TCS Campus Commune Program.
2	Interactive Session (TCS Representative)	Aug, 2015	An interactive session with Anurag Chawla and Vaibhav Bansal both employed at TCS.
3	Sales force Training		Students were trained on modules of Trailhead.

# [SELF ASSESSMENT REPORT]



## Training in Institute:

Year	Name of event	Object of event	No. of students participated	Date of event
2015-16	Pre Placement training Program by FACE	Bridging gap between academics & Industry	180	12-10-2015 To 14-10-2015
2016-17	Pre placement training by Face	Bridging gap between academics & Industry	184	18-7-2016 To 6-8-2016
2017-18	Pre placement training program by Face	Bridging gap between academics & Industry	186	20-7-2018 onwards

## Entrepreneurship

Institute has a cell which improve entrepreneurship development skills in students by doing activities such as seminars, workshops and awareness camps.(Entrepreneurship and incubation).

- To improve Entrepreneurship skills in students.
- Cell conducts many workshops and awareness camps for students.
- Cell has incubation center and associated with startups.
- Cell schedules interactions with alumni startups.

S.No.	Name of Event	Date	Description
1	JOSH Meets	May 2016	JOSH Meets, an opportunity for interactive sessions with six achievers from various fields
2	Interactive session With Alumni	August 2016	An interactive session with the alumnus of JECRC & Co-Founder, celebal, Sh. Anirudh Kala was conducted training & placement opportunities for students of JECRC at Celebal were identified.
3	Orientation Session  Organized by Career Development Centre, JECRC	2017	Career Development Centre, JECRC & Intraversity organized an orientation session for students to help them grab international internship opportunities. Dr. Harsh Mishra, Founder iSEED & Dr. K. C. Jacob, President & Managing Consultant, Horton International spoke to students about opportunities in Singapore & Hong Kong.
4	TEDx Talk	March 2017	The first TEDx talk in any RTU affiliated college was conducted in JECRC on 25th March 2017 wherein 10 international speakers spoke to our students.
5	Entrepreneurship awareness camp	March 2016	A three day Entrepreneurship Awareness Camp was organized at JECRC in association with DST The camp witnessed a registration of 300 students and a footfall of 12 eminent speakers from the start up ecosystem of the country.



## [SELF ASSESSMENT REPORT]



6	Workshop on Entrepreneurship Skill development	Feb, 2016	A workshop was conducted by EDC, JECRC on Entrepreneurship Skill Development The expert speaker was Dr. Pankaj Bharti from Entrepreneurship Development Institute of India.
7	Interactive session Motivational speaker	September 2015	An interactive session for students by renowned motivational speaker Mr. Vijay Batra



### Entrepreneurship awareness camp

#### Government Job Cell

Government job cell established in our institute in the year 2016, to prepare students towards different competitive examinations. In this cell we encourage and inspire students for competitive examination by doing activities like interactive sessions with central government head, NBS head.

S.No.	Name of Event	Date	Description
1	Interactive Session NBS by G. D. Bakshi	October 2015	An interactive session with Major Gen. Dr. G. D. Bakshi was organized for students in October 2015.
2	Interactive Session with the "Metal King of India"	November 2015	An interactive session with the "Metal King of India", Mr. Anil Agarwal, Chairman, Vedanta Resources Plc.
3	Interactive Session By MHRD, Government of India	February 2017	An interactive session with Sh. Anil Swarup, Secretary, (SE & L), MHRD, Government of India was organized for students of JECRC.
4	JECRC MUN	April 2017	The 6th edition of JECRC MUN was held in April 2017, presenting five different committees UN GA-DISEC, NSC, UN HRC, SOCHUM & ICJ.
5	7 <sup>th</sup> Edition of JECRC MUN	April 2017	GA-DISEC, UNSC, UN-HCR, CSW AND Lok sabha along with international press.



**Interactive session with Major Gen (Dr.) G.D.Bakshi**



**Interactive session with Metal king Sh. Anil Agarwal**



JECRC MUN 2017



JECRC MUN 2018

## Industry Visit

We schedule industry visits for students so they can see and learn technologies in industry also observe professional environment in industry. It helps to bridge gap between industry and academics. Students learn about latest platforms to be work upon.



**Industry:** CIPET, Jaipur

**Resource Person:** Mr. Rakesh Bangha

**Date:** 06-09-2017



**Industry:** MSME, Jaipur

**Resource Person:** Mr. Pradeep Ojha

**Date:** 15-02-2017



**Industry:** MSME, Jaipur

**Resource Person:** Mr. Pradeep Ojha

**Date:** 15-02-2017

**All round development:**

Many technical events like conferences and workshops are organized in the institute to improve and present technical skills of students.

- National level competitions for students like Smart India Hackathon were held in institute.
- To prepare teams a faculty guide was assigned to a particular team and an intra college competition like JECRC hackathon was organized to check, improve technical skills level of shortlisted teams.

**List of Professional Societies/Chapters and Organizing Engineering Events in CAY (2017-18)**

S.No.	Name of Professional Societies / Chapters	Organized Event	Organized Period	Level of Event (Institute/ State/ National/ International)	Event Outcome	PO/PSO
1	Mech-Tech Club	Conference [NCFTME 2018]	March25-26, 2018	National	Students and research scholars were made aware about the recent trends in the field of renewable	PO1,PO4,PO10 <b>PSO1, PSO2</b>

## [SELF ASSESSMENT REPORT]



					energy	
2	ISST	RITDME 2018 International conference	April 6-7, 2018	International	Students and research scholars were made aware about the field of ritdme.	PO1,PO4,PO10 , PSO1,PSO2
3	NITTR, Chandigarh	Short Term Course On “Product Design And Development”	7-11 NOV. 2017	Institute	The entire program and the overall program was very satisfactory & learner-centric.	PO1,PO2,PO3, PO10,PO11,PO 12,PSO2
4	Mech- Tech Club	TECH-FEST, 2018	25-28 March2018	National	Techfest has provided platform to participate in innovative activities.	PO1,PO3,PO4, PO9,PO10,PO1 2,PSO1,PSO2
5.	SKYFI LABS	3-D Printing Workshop	25-26 October201 7	Institute	Students can create a <u>three-dimensional</u> object in which layers of material are formed under <u>computer control</u> to create an object.	PO1,PO2,PO3, PO4,PO5,PSO2
6.	BAJA TUTOR	Workshop	1 –2 Dec 2017	Institute	students got to know about complete knowledge of the automobiles	PO1,PO2,PO3, PO4,PO5,PO9, PO12,PSO1

### List of Professional Societies/Chapters and Organizing Engineering Events in CAYm1 (2016-17)

S.No.	Name of Professional Societies / Chapters	Organized Event	Organized Period	Level of Event (Institute/ State/ National/ International)	Event Outcome	PO/PSO
1	ISST, Gaziabad	<b>Conference</b> <b>[RESSD-2016]</b>	07-08 October, 2016	National	Students and research scholars were made aware about the recent trends in the field of renewable energy.	PO1,PO4,PO1 0,PSO1,PSO2

## [SELF ASSESSMENT REPORT]



2	NITTTR, Chandigarh	Department of Mechanical Engineering organized an ICT based short term course on “New Manufacturing Technologies” in association with NITTTR Chandigarh	07-11 November, 2016	National	Faculty members gained extensively details of new materials, manufacturing technologies, manufacturing processes	PO1,PO2,PO3, PO10,PO11,PO12,PSO2
3	Mech-Tech Club	TECH FEST2017	06-11 March 2017	National	Tech fest has provided platform	PO1,PO3,PO4, PO9,PO10,PO12,PSO1,PSO2
4	Cadd Centre	ANSYS Training Programme	05-07 March, 2017	Institute	Knowledge about software	PO1,PO2,PO3, PO4,PO5,PO12,PSO2
5	Engineers Academy	Guest Lecture on Career Counselling	29 August 2016	Institute	Extra knowledge about subject	PO6,PO8,PO9, PO10,PO12
6.	Baba Automobiles	Guest Lecture on Introduction to Various Types of Automobile Engines	01 October 2016	Institute	Knowledge about Automobile Engines	PO1,PO2,PO3, PO4,PO5, PO12,PSO1
7.	Baba Automobiles	Work Shop on Assembling and Disassembling of 2 & 4 Stroke Engines.	15-19 November 2016	Institute	Knowledge about 2 & 4 Stroke Engines	PO1,PO2,PO3, PO4,PO5, PO12,PSO1

## [SELF ASSESSMENT REPORT]



S. No	Name of Event	Date	Description
1	J Techtrix (An exhibition)	April 2017	J Techtrix, a day long exhibition of projects of our students was held at JECRC in April 2017 wherein more than forty selected projects were on display
2	Interactive Session(TCS commune Program)	2017	The talent acquisition head, North India for TCS, Mr. Narendra Chandel visited JECRC to interact with students regarding the TCS Campus Commune Program.
3	SIH-2K17 (Smart India Hackathon) Organized by MHRD, Govt of India	April 2017	The grand finale of Smart India Hackathon organized by MHRD, Govt of India was held at JECRC. JECRC was among the only twenty-six colleges selected in the country for this event wherein "47" teams from all over India came to participate in a 36-hour nonstop coding competition.
4	J Techtrix an Exhibition	Nov, 2015	A two day exhibition of projects of 1st Year students was held at JECRC
5	Interactive Session (TCS Representative)	Aug,2015	An interactive session with Anurag Chawla and Vaibhav Bansal both employed at TCS
6	Interactive Session ( TCS Campus Commune Program )	2015	The talent acquisition head, North India for TCS, Mr. Narendra Chandel visited JECRC to interact with students regarding the TCS Campus Commune Program
7	"Sustainability Development: Challenges & Opportunities. (Short term training course)	From 12th To 16th October 2015	Mechanical Department in association with NITTTR, Chandigarh on "Sustainability Development: Challenges & Opportunities.
8	"Automotive Design and Development" (A training Program)	From 8th To 22nd February 2016.	"Automotive Design and Development" in association with Elite Techno Group
9	J-Techtrix 3 <sup>rd</sup> Edition Exhibition	17 <sup>th</sup> March 2018	JECRC's student project exhibition.
10	SIH-2K18 (Smart India Hackathon) organized by MHRD, Govt of India	30 <sup>th</sup> -31 <sup>st</sup> March 2018	JECRC was among the only twenty eight colleges selected in the country.





J-Techtrix 2018

### 9.6. Entrepreneurship Cell (5)

Entrepreneurship cell is established in mentorship of Mr. Siddharth Chaturvedi, our College for encouraging and inspiring students for start-ups and entrepreneur. Various interactive sessions for students with alumni and start-up representative are organized to know the importance of being an entrepreneur and ways to get financial assistance to become an entrepreneur.

Cell is responsible for:

- Relationship with companies:
  - ❖ Company like celebal tech has visited our campus for 2017-18 batch placements and this company is owned by jecrc alumni.
  - ❖ Backbone softwares also visited jecrc campus and owned by JECRC alumni.(2010 batch)
- Motivate students, guide and help them in the same direction.

#### EDC Activities:

Year	Name of the event	Conducted by	Date	Participants
2015-16	Entrepreneurship awareness camp	DST govt of raj	28-3-2016 to 30-3-2016	25
2016-17	Entrepreneurship awareness camp	DST govt of raj	2-9-2016	60
2017-18	Entrepreneurship awareness camp	JECRC	29,30-8 2017	63

## [SELF ASSESSMENT REPORT]



Currently the below mentioned startups are working as an incubates at JECRC Incubation Cell sharing the co-working space provided by the Institution

1	Akshat Garg/Mayank Vijay	2018	CSE/ECE	VeGuide
2	Harshil/Manav/Khusagra	2018	ECE	Inventocrates
3	Kushagra Singh	2018	ECE	Pratikriya
4	Aditya Vardhan	2018	ECE	SkillAux
5	Aditya ostwal/Keshav Jangid	2018	First Year	ARFurni
6	Akshay Patni	2018	CSE	DigWoo
7	Anil Lohar	2018	ECE	AMIGO AI
8	Akshay Patni	2018	CSE	Inncx

### 9.7. Co-curricular and Extra-curricular Activities (10)

#### Co-curricular Activities:

#### Guest lecture/ Workshops/ Industrial visits (2016-17) to attained the POs

Guest lecture/ Workshops/ Industrial visits (2016-17)								
S#	Subject	Sem.	Gap/ content	Action Taken	Date	Resource	% of students presente d	Relevance to POs
1	Aptitude , Reasoni ng, Quantita tive/ group discussi on/ HR Training	VII	Aptitude/ group discussion/ HR training/ Reasoning, Quantitativ e	Training	July 20- Augu st 14, 2016	Face academy	>90%	PO8, PO9, PO10, PO12
2	I.C. Engines	IV	Working of Six stroke engine	Guest Lecture	01- 10- 2016	Mr. Nimesh Baba	>80%	PO1, PO2, PO3, PO6, PO7, PO12, <b>PSO1</b>
3	Newer Machini ng Methods	VII	Advancem ent in EDM	Guest Lecture	07- 10- 2016	Dr. Anand Pandey	>80%	PO1, PO2, PO3, PO4, PO5, PO6, PO7, PO12
4	Engineer ing Thermodyn amics	III	Application of Advanced Thermodyn amics	Guest Lecture	17- 10- 2016	Mr. Pramod Vashistha	>80%	PO1, PO2, PO3, PO6, PO7, PO12

## [SELF ASSESSMENT REPORT]



5	I.C. Engines and Automobile Engineering	IV/V	Different aspects during designing of ATV	Workshop	15-19 November 2016	Mr. Nimesh Baba	>80%	PO1, PO2, PO3, PO4, PO5, PO6, PO7, PO12, <b>PSO1</b>
6	Refrigeration & Air Conditioning	VII	Air conditioning maintenance	Guest Lecture	17-02-2017	Mr. Alok Bhargava	>80%	PO1, PO3, PO4, PO5, PO6, PO7, PO12
7	CAD/CAM	VIII	Basic introduction of CREO	Guest Lecture	08-03-2017	Mr. Praveen Jain	>80%	PO1, PO3, PO4, PO5, PO6, PO12, <b>PSO2</b>
8	CAD/CAM	VIII	Basic introduction of Inventor	Guest Lecture	09-03-2017	Mr. Gaurav Jalan	>80%	PO1, PO3, PO6, PO12, <b>PSO2</b>
9	Quality Assurance & Reliability	V	Advance quality improvement tools	Guest Lecture	10-03-2017	Mr. Amit Soni	>80%	PO1, PO2, PO5, PO6, PO8, PO12
10	Design of Machine Elements-1 & Design of Machine Elements-2	IV/V I	Design consideration during design of roller bearing and testing of different types of bearing	Guest Lecture	11-03-2017	Mr. Abhishek Singh	>80%	PO1, PO2, PO3, PO5, PO6, PO12, <b>PSO2</b>
11	Finite Element Method	VII	Buckling analysis of mechanical components subjected to different type of loads	Workshop	05-07 March, 2017	Mr. Rajeev Bhargav	50 Students	PO1, PO2, PO3, PO4, PO5, PO12, <b>PSO2</b>
12	Machining & Machine Tools	IV	Working of advance machine tools	Industrial Visit	15th Feb, 2017	Mr. Pradeep Ojha	30 Students	PO1, PO2, PO3, PO4, PO5, PO12

## [SELF ASSESSMENT REPORT]



13	Sociology and economics for engineers	ALL	Social events	Social activity		Abhudhya	ALL	PO6, PO7, PO8, PO9, PO10, PO11, PO12
14	National Conference on Futuristic Engineering Trends in Mechanical Engineering		Advance research in Mechanical engineering	National Conference		Mechanical Department	All	PO1, PO2, PO3, PO4, PO5, PO12

### Guest lecture/ Workshops/ Industrial visits (2017-18) to attained the POs

Guest lecture/ Workshops/ Industrial visits (2017-18)								
S#	Subject	Se m.	Gap/ content	Action Taken	Date	Resource	% of students present ed	Relevance to POs
1	Aptitude, Reasoning, Quantitative/ group discussion/ HR Training	VII	Aptitude/ group discussion/ HR training/ Reasoning, Quantitative	Training	Jul-17	Face academy	>90%	PO8, PO9, PO10, PO12
2	Mechanics of Solids	III	Stress analysis in fixed beam	Guest Lecture	11-08-2017	Mr. Abhishek Kumar	50 Students	PO1, PO2, PO3, PO4, PO5, PO12
3	Automobile Engineering	V	Different aspects during designing of ATV	Guest Lecture	21 Aug.2017	Mr. Nimesh Baba	50 Students	PO1, PO2, PO3, PO5, PO12, <b>PSO1</b>
4	CAM	VII	Advance CNC programming for cutter/nose radius compensati	Industrial Visit	06-09-2017	Mr. Rakesh Bangha	30 Students	PO1, PO2, PO3, PO5, PO12,

## [SELF ASSESSMENT REPORT]



5	Professional Ethics and Disaster Management	V	Waste Management in hospital	Industrial Visit	14th Sept. 2017	Mr. Santosh Bansal	30 Students	PO1, PO6, PO7, PO12
6	Computer Integrated Manufacturing Systems	VII	3-D Printing	Workshop	25-26 Oct. 2017	Mr. Promod Kumar	30 Students	PO1, PO2, PO3, PO4, PO5, PO12,
7	Automobile Engineering and I.C. Engines	IV	Working of Six stroke engine	Workshop	1 –2 Dec 2017	Mr. Nimesh Baba	30 Students	PO1, PO2, PO3, PO4, PO5, PO9, PO12
8	Sociology and economics for engineers	ALL	Social events	Social activity		Abhudhya	ALL	PO6, PO7, PO8, PO9, PO10, PO11, PO12
9	CAD	IV and VI	Solid works	Training	8/3/2018-5/4/2018	Mr. Rakesh	38	PO1, PO2, PO3, PO4, PO5, PO12
10	CAD	IV and VI	Autocad	Training	31/1/2018-23/2/2018	Mr. Karan	32	PO5, PO10, PO12
11	Finite Elements Method	IV and VI	Buckling analysis of mechanical components subjected to different type of loads using ANSYS	Training	31/1/2018-23/2/2018	Mr. Kamlesh	25	PO1, PO2, PO3, PO4, PO5, PO12
12	Material science	III	Introduction of nano tubes and nano particles	Guest Lecture	6/4/2018	Dr. Alba Baena	>80%	PO1, PO2, PO3, PO4

## [SELF ASSESSMENT REPORT]



13	Micro and Nano Manufacturing	VII	Advance welding technology	Guest Lecture	6/4/2018	Dr. Meghanshu Vashista	>80%	PO1, PO2, PO3, PO4
14	Operation Management	VII	Application of ERP in industry	Guest Lecture	7/4/2018	Dr. Ashok Sharma	>70%	PO5, PO1
15	Recent Innovations & Technological Development in Mechanical Engineering		Advance research in Mechanical engineering	Conference		Mechanical Department	All	PO1, PO2, PO3, PO4, PO5

### GUEST LECTURES:



**Guest Lecture Topic:** Advancement of Engines

**Resource Person:** Mr. Nimesh Baba

**Date:** 01-10-2016



**Guest Lecture Topic:** Application of Advanced Thermodynamics

**Resource Person:** Mr. Pramod Vashistha

**Date:** 17-10-2016

#### WORKSOPS:



**Workshop Topic:** Assembling and Disassembling of 2 & 4 Stroke Engines

**Resource Person:** Mr. Nimesh Baba

**Date:** 15-19 November 2016



**Workshop Topic:** ANSYS Training

**Resource Person:** Mr. Rajeev Bhargav

**Date:** 05-07 March, 2017



**Workshop Topic:** Assembling & Disassembling of the automobiles

**Resource Person:** Mr. Nimesh Baba

**Date:** 01 - 02 Dec 2017



**Pre Placement Training/ Extra Technical Classes**

Year	Name of event	Object of event	No. of students participated	Date of event
2015-16	Pre Placement training Program by FACE	Bridging gap between academics & Industry	180	12-10-2015 To 14-10-2015
2016-17	Pre placement training by Face	Bridging gap between academics & Industry	184	18-7-2016 To 6 - 8-2016
2017-18	Pre placement training program by Face	Bridging gap between academics & Industry	186	20-7-2018 Onwards



**Alumni Session:**

**Alumni Session 24<sup>th</sup> August & 27 August 2017:**

Alumni sessions were organized by mechanical department on 24 Aug & 27 Aug for the students eligible for upcoming placement drive of Accenture.

Two sessions were organized in this session and our Alumni of 2017 batch were among the motivational speakers. In first session on 24 Aug. was given by Mr. Rishil Gupta (got selected in Accenture & TTL) motivated the students and gave them the tips & techniques to get through the placements.

The second session on 27 Aug. was given by Mr. Anurag Verma who got placed in Accenture & Mr. Anshul Khandelwal who got selected in Accenture & TTL. Our Alumni shared their experience of getting placed & the beautiful journey they had in JECRC and told the to believe in yourself and to remember if the situation is not going according to you than pick yourself up, re-mind yourself why you're amazing, and try again for a new role.



**SOCIAL ACTIVITIES:**



**DONATE BLOOD & BE SOMEONE'S SUPERHERO**

**[BDC-2017]**

**Date: 11<sup>th</sup> october 2017**



**SAVE GIRL CHILD**

[Suhasini]

**Date:** 8<sup>th</sup> March 2018



**CELEBRATING INNOCENCE**

[Zarurat]

**Date:** 24<sup>th</sup> March 2018



**CLEANINESS DRIVE**

[SOCH]

**Date:** 11<sup>th</sup> April 2017

- Each team who participated in 2017 and 2018 SIH held at JECRC were guided by assigned faculty member so they can perform better.

Year	No. of students participated	No. of teams
2016-17	18	3
2017-18	24	4

**Extra Curricular activities:**

Student's participation in National and International conferences, in Technical Workshops, Intra and Inter college competitions:

## [SELF ASSESSMENT REPORT]



### *Participation in Inter-Institute Events by Students in CAYm2 (2015-16)*

S.No.	Name of students	Event	Date	Organized by	Event outcomes	PO/PSO
1.	Abhimanyu Singh Bhati, Anshulkhandelwal, MradulAgarawal	Vertual Baja SAE India - 2015	10&11 july2015	Chitkara University Punjab	Participation	PO1,PO2,PO4, PO5,PO9,PO12 ,PSO1,PSO2
2.	ArunYadav,AnuragVerma	EFFI-CYCLE, 2015	4&5 July2015	KIET, Gagiyabad	Participation	PO1,PO2,PO3, PO4,PO5,PO9, PO11,PO12,PSO1,PSO2
3	AdilAhamadfari, AmanGupta, Akshyakumarsoni, akshaykirtisharma	SAE-INDIA, Student Convention	10 Oct.2015	SKIT, Jaipur	Participation	PO1,PO2,PO10 ,PO12,PSO1
4.	Amit Modi, Akash Jain	Esuemmit 2015	28-30 Aug.2015	IIT, Kanpur	Participation	PO11
5	Abhishek Bhardwaj,	Full throttle grand prix	25-29 March 2015	BITS PLANI	Ist, position	<b>PO1, PO2,PO3,PO5, PO9,PSO1,</b>
6	Abhimanyusingh Bhati	Robo-War	25-29 March 2015	BITS PLANI	I <sup>st</sup> , position	PO1,PO2,PO3, PO9,PO11
7	MohitYadav	Dance,X-Animo-2015	9to10 Oct. 2015	Gyanvihar	II <sup>nd</sup> Position	PO9
8	Kapil Sharma	National Conferance	13-14 March 2015	JIMS, Jaipur	Participation	PO1,PO4,PO10 ,PSO1,PSO2
9	PriteshChandhok, Rohan Sharma, AnuragVerma, ArunYadav	Efficycle-2015	15-18 Oct. 2015	Lovely Professional university, punjab	Participation	PO1,PO2,PO3, PO4,PO5,PO9, PO11,PO12,PSO1,PSO2

## [SELF ASSESSMENT REPORT]



### *Participation in Inter-Institute Events by Students in CAYm1 (2016-17)*

S.No.	Name of students	Event	Date	Organized by	Event outcomes	PO/PSO
1	Mr. HarshulKhandelwal, Mr. Aditya Yadav, Mr. Gaurav Lodha, Mr. BhupendraSuman	<b>Robowar</b>	01-04 September 2016.	IIT Guwahati	secured 8 <sup>th</sup> Position	PO1,PO2,P03,PO9,PO11
2	Mr. PankajMaharshi, Mr. Pankaj Sharma, Mr. Yash Sharma, Mr. DivyankRathi, Mr. Sourabh Gupta, Mr. YashwantKhandelwal, Mr. Himank Dave, Mr. YeeshuDwivedi and Mr. RajatShrivastav	Automobile Mechanics & IC Engine in “RENDEZVOUS”	21-24 October 2016	IIT Delhi	<b>participate</b>	<b>PO1,PO2,P03,PO4,PO5,PO12,PS01</b>
3	SourabhMangal and Satyam Jain	MESH FLARE	16-18 Dec. 2016	IIT Bombay	<b>Participate</b>	<b>PO1,PO2,P03,PO4,PO5,PO9,PO11,PSO2</b>
4	HarshulKhandelwal	ROBOWAR	LNMIT	18 <sup>th</sup> to 20 <sup>th</sup> Jan, 2017	won 2 <sup>nd</sup> prize	PO1,PO2,P03,PO9,PO11
5	GouravLodha	RC Car event	at Baba Farid College of Engineerin	27 <sup>th</sup> to 30 <sup>th</sup> Jan 2017.	<b>Participate</b>	<b>PO1, PO2,PO3,P05,PO9,PS01,</b>

## [SELF ASSESSMENT REPORT]



			g & Technology, Bhatinda			
6	Mr. Arpit Natani (III Year) and Arpit Agarwal (III Year)	RC car	RTU, Kota	15 <sup>th</sup> -18 <sup>th</sup> February 2017	won 2 <sup>nd</sup> prize	<b>PO1, PO2, PO3, PO5, PO9, PS O1,</b>
7	Moonrider Club of JECRC	Go Cart event “	Elite Carting” at Bhopal	14 <sup>th</sup> to 20 <sup>th</sup> February 2017	participated	<b>PO1, PO2, PO3, PO4, PO5, PO9, PO10, PO11, PO12, PS O1, P SO2</b>
8	A team of 5 students	RC Car event	MIT and DY Patil, Pune	6 <sup>th</sup> to 11 <sup>th</sup> February 2017	participated	<b>PO1, PO2, PO3, PO5, PO9, PS O1,</b>

### *Participation in Inter-Institute Events by Students in CAY (2017-18)*

S.No.	Name/No. of students	Event	Date	Organized by	Event outcomes	PO/PSO
1	Mohit Menaria Lavneet Jhasal Devendra Kumar Vijay Krishna Agarwal Kishan Kumawat Jayant Sati Dattatrehy Singh Shekhawat Usama Sherwani Vikash Jain Deepak Choudhary Shubham Wadhwa Prince Kumar Sharma Govind Saini Yash Dangi Vikram Pratap Singh	The Motocross	17/03/2018	NKRC <i>Season-4</i>	“Stig Award” and “Rs 10000” cash reward.	PO1, PO2, PO3, PO4, PO5, PO9, PO10, PO11, PO12, PS O1, PSO2

## [SELF ASSESSMENT REPORT]



	Sumit Jain Saksham Soni Pankaj Jangid Aditya Agarwal Vikas Jain Shubham Wadhwa Anuj Tiwari Govind Saini					
2	Deepak Kurup Anirudh Singh Chouhan Govind Saini Anuj Tiwari Kishan Kumawat Pratyush Bhardwaj Harshil Pandit Saksham Soni Pawan Kumar Suthar Himanshu Bansal Parul Yadav Manish Kumar Shamra Abhijeet Sharma Jitendra Devnani Deepak Sharma Harsh Mantri Bharat Pursnani Abhijeet Singh Rathore Prince Kumar Sharma Ajay Jadam Piyush Pursnani Naman Vijayvargiya Shubham Wadhwa Saurabh Singh Aditya Agarwal Abhishek Kumar Mohsin Khan Md.Aman Luhar Mohit Vaishnav Manish Saini Vikash Jain Mohit Nagpal	Moon Riders JECRC @ N K R C	29/9/17- 5/10/17	Radharam nEngg. College, Bhopal	Performed very well	PO1,PO2,PO3,P O4,PO5,PO9,PO 10,PO11,PO12,P SO1,PSO2



## [SELF ASSESSMENT REPORT]



3	Manish Sain Aditya Upadhyay Abhishek Kumar Harshil Pandit Jaideep Mahendra Harshit Jain Deepak Mittal Ashutosh Dadhich Jitendra Deynani Himanshu Pagariya Himanshu Jangir Mihir Panchal Vikas Yadav Rishabh Goyal Bhanu Prakash Gupta Chandra Prakash Fulueani Devendra Pratap Yadav Akshay Kumar Anurudh Singh Arjun Singh Deora	Go-Kart	11.01.18 to 15.01.18	Kolhapur under SAE	Performed very well	PO1,PO2,PO3,P O4,PO5,PO9,PO 10,PO11,PO12,P SO1,PSO2
4.	Pankaj Mahrishi &Yadunandan Gautam	GEETA GYAN PRATIYO GITA	2018	SKIT,Jaipu r	Students got 2nd position	PO10,PO9

### *Consolidated Students Participation in inter-institute events*

Description	No. of Students Participated		
	CAY (2017-18)	CAYm1 (2016-17)	CAYm2 (2015-16)
Within the State	40	30	35
Outside State	96	100	30
Prize/Awards Received	26	42	04

## [SELF ASSESSMENT REPORT]



Session 2015-16

S. No.	Name of event	Date	Details
1	blood group check-up camp	Sep 2015	A Blood group check-up camp was organized for students.
2	International Book Fair	Sep 2015	International Book fair was organized for students.
4	An interactive session for students by renowned motivational speaker Mr. Vijay Batra.	Sep 2015	Interactive session was organized for students to get motivated.
5	Regional auditions of Mood Indigo.	Oct 2015	It was an IIT Mumbai event, regional auditions were held in JECRC for students across state.
6	An interactive session with Major Gen. Dr. G. D.	Oct 2015	An interactive session was organized for students with Gen .Dr. G. D Bakshi who shared experience at LOC and motivated student for jobs.
7	A musical ensemble of Kabir's Dohe was presented by Mr. Vipul Rikhi of the Kabir project.	Oct 2015	A musical ensemble of kabir's dohe was presented, session was specifically about kabir project and students knew about it.
8	The annual JECRC Foundation Blood Donation Camp was organized	Oct 2015	Blood donation camp was organized; students donated blood and spread awareness.

## [SELF ASSESSMENT REPORT]



9	Interactive session with worlds only Hexa CCIE +CCDE	Oct 2015	Session was held in jecrc for students exclusively.
10	An interactive session with the "Metal King of India", Mr. Anil Agarwal	Nov 2015	A session with metal king was organized in JECRC where metal king shared his views and experience also motivated students.
11	The ideation feedback and social media contest under the Digital for Customer Engagement program of SAP, U.S	Nov 2015	Ideation feed back and social media contest.
12	Mr. Abhishek Bachchan and the Jaipur Pink Panthers team were in JECRC	Feb 2016	Mr. Abhishek bacchan and the jaipur Pink Panthers team visited JECRC and students for promotions.
13	A cleanliness drive was conducted by the student group Abhyuday-SOCH of JECRC	March 2016	A cleanliness drive was conducted by group Abhyuday-SOCH students and students cleaned campus.
14	Musical performance and interactive session with mr. and mrs vinay mahajan	March 2016	Performance was given by Mr. and Mrs. Vinay mahajan,, students learnt a lot .
15	An interactive session was organized for students in March 2016 with Ms. Temsutula Imsong, known as the "Action Hero of Ganga's Ghats".	March 2016	Students aware about " Action Hero of Ganga's Ghats" in this session.
17	A special performance was organized for students by renowned	March 2016	A special performance was organized for

## [SELF ASSESSMENT REPORT]



	Kathak dancers, Devendra Sharma & Abhas Sharma		students by renowned Kathak dancers, Devendra Sharma & Abhas Sharma
18	Group Abhyuday - Suhasini on 8th March. A Nukkad Natak was presented by the students on this occasion to create awareness against female feticide.	March 2016	Nukkad Natak was presented by the students of group Abhyuday- Suhasini to create awareness against female feticide. against
19	An exhibition by ISRO	April 2016	ISRO conducted exhibition in JU, students of JECRC were participated.
20	Felicitation Day	March 2016	Felicitation Day was celebrated among students.

### Session 2016-2017

S. No.	Event Name	Date	Details
1	Students participated in Accenture career day.	Aug 2016	Accenture career day was celebrated in JECRC UDML college (Jecrc foundation) where JECRC students participated. Gathering was graced by MD of Accenture Mr. khonsala and VP of recruitment.
2	70 th independence day celebrations.	Aug 2016	Independence day was celebrated in JECRC.

## [SELF ASSESSMENT REPORT]



3	Regional auditions for antaragini , fest of IIT kanpur.	Aug 2016	Regional auditions were held in JECRC for IIT Kanpur fest.
4	Induction day celebration	Aug 2016	Induction day was celebrated for 2019 batch. It was also an awareness program for Anti-ragging.
5	Vandey matram-voice of unity.	Sep 2016	Thousands of student participated across state. JECRC students were also part of this.
6	An alumni meet in New York USA.	Sep 2016	An alumni meet in new York was organized for JECRC Alumnus.
7	Spiritual cell inauguration	Oct 2016	First spiritual cell in engineering college in Rajasthan was inaugurated.
8	Blood donation camp by Abhyuday group-ashayein.	Oct 2016	Blood donation camp was organized; students donated blood and spread awareness
9	An alumni meet in Mumbai pune	Dec 2016	An alumni meet in mumbai was organized for JECRC Alumnus.
10	National girl child day	Jan 2017	National girl child day was celebrated in JECRC.
11	68 Republic day	Jan 2017	Republic day was celebrated.
12	8 edition of AU jaipur marathon	Feb 2017	AU Jaipur marathon was organized in city and students of JECRC

## [SELF ASSESSMENT REPORT]



			participated.
13	Social group activity by Abhyuday group-Zarurat,	March 2017	Abhyuday group-zarurat organized an event for children , some competitions were held in
14	Sports activity during RENAISSANCE.	March 2017	Many sports activities and competitions were organized for students during annual fest RENAISSANCE.
15	National level cultural fest RENAISSANCE	March 2017	National level cultural fest RENAISSANCE .
16	Accenture international women's day celebration	March 2017	International women's day was celebrated.
17	Made Biggest flower basket by Abhyuday group-zarurat.	March 2017	Kids of Abhyuday group-zarurat made biggest flower basket.
18	A road safety seminar by NGO	March 2017	A seminar was conducted on road safety by an NGO.
19	Post office Promotional Event	April 2017	

### Session 2017-2018

S. No.	Name of event	Date	Details
1	Deputy high commissioner of U.K. visited JECRC.	July 2017	Visit of Deputy High Commissioner was held in JECRC.
2	JECRC Alumni were awarded on first year induction day.	Aug 2017	An induction day for 2021 batch was celebrated and alumni were awarded on this day.
3	An engineer's day celebration, Top rankers in RTU and achievers in sports were decorated.	Sep 2017	An engineer's day celebrated in JECRC, top rankers and achievers were

## [SELF ASSESSMENT REPORT]



			awarded.
4	“Swacchata Pakhwada” celebrated, Cleanliness raised.	1 to 15 Sep 2017	15 days celebration took place as “Swacchata Pakhwada” in JECRC, students were participated in this activity, checked for clean campus.
5	Seminar on “Rally for Rivers”.	Sep 2017	A seminar on “Rally for Rivers” was held in JECRC. Students participated.
6	An interactive session by kiran seth on SPIC MACAY.	Sep 2017	A session by Mr. Kiran seth on SPIC MACAY, students were part of this.
7	OMEN by HP and mountain dew ESL india college gaming championship.	Oct 2017	A college championship of gaming competition was held.
8	Blood donation drive	Oct 2017	Blood donation camp was organized for students. They donated blood.
9	Vandey matram-voice of unity	Nov 2017	Thousands of student participated across state. JECRC students were also part of this.
10	An invited talk with prof.peter kent and prof. david wing CEO UKEL.	Nov 2017	Session was organized in JECRC for students.
11	National girl child day celebration	Jan 2018	National girl child day was celebrated in JECRC.
12	69 th republic day celebration	Jan 2018	Republic day was celebrated
13	OCIP(orphanage children interactive program) by Abhyuday group- SOCH	Feb 2018	An event organized by abhyuday group-SOCH, which were for orphanage children.
14	An invited Talk on” Society and control system” by vice chancellor RTU Kota.	Feb 2018	Chancellor RTU kota presented talk on Society and control system.
15	National level cultural fest RENAISSANCE.	March 2018	National level cultural fest RENAISSANCE
16	Social group activity by Abhyuday group-Zarurat	March 2018	Abhyuday group-zarurat organized an event for children ,

## [SELF ASSESSMENT REPORT]



			some competitions were held in JECRC
17	Sports activity during RENAISSANCE.	March 2018	Many sports activities and competitions were organized for students during annual fest RENAISSANCE.
18	Seminar on entertainment industry by alumnus.	March 2018	Seminar was held by JECRC alumnus on entertainment in JECRC.
19	An Exhibition by ISRO	April 2018	ISRO conducted exhibition in JU, students of JECRC were participated



**Renaissance 2015-16**



**Mr. Abhishek Bachchan and the Jaipur Pink Panther's team were in JECRC 2015-2016**





An exhibition by ISRO 2015-16



BDC 2015-16





**Josh Meet 2015-16**



**8<sup>th</sup> Edition of AU Jaipur Marathon 2016-17**



on the  
**FELICITATION  
DAY**





Regional auditions for antaragani , fest of IIT Kanpur.



BDC 2016-17



Vande Matram 2016-17



Post Office Promotional Event 2016-2017



Rajiv Gupta RTU Vice Chancellor

## जेईसीआरसी में स्वच्छता को लेकर अनूठा प्रयास अब क्यूआर कोड से आएगी सफाई में तेजी

जयपुर (कांस)। सीतापुर स्थित जेईसीआरसी कॉलेज में मंगलवार को माननीय प्रधानमंत्री नरेन्द्र मोदी के स्वच्छ भारत अभियान को एक कदम और



बढ़ाते हुए इंजीनियरिंग विद्यार्थियों ने सफाई व्यवस्था में तेजी लाने के उद्देश्य से 'स्वच्छ जेईसीआरसी' अभियान की शुरुआत डिजिटल रूप से की। विद्यार्थियों ने पूरे कॉलेज का नक्शा तैयार कर और उसे एक क्यूआर कोड से जोड़कर कॉलेज के एक सर्वर पर कनेक्ट कर सम्पूर्ण जेईसीआरसी कॉलेज को उससे जोड़ दिया, जिससे कहीं भी किसी भी तरह की सफाई की परेशानी और अव्यवस्था का पता चंद सेकंड्स में पता लग जाएगा, और तुरंत कार्यवाही के लिए प्रेषित कर दिया जाएगा। कार्यक्रम में जेईसीआरसी कॉलेज के सीनियर एडवाइजर पी के तिवारी, ओ पी जैन सहित कई गणमान्य नागरिक उपस्थित थे।

Page No. 3, Apr 13, 2017  
Powered by: uritego.com

### Soch 2016-17



### Vande Matram 2017-18



Drive was conducted by the A cleanliness student group SOCH of JECRC



## सुहासिनी ने मनाया नई उड़ान का जश्न

**जयपुर (कासं)।** सीतापुरा स्थित जेईसीआरसी फाउन्डेशन के सामाजिक उत्थान के लिए चलाई जा रही श्रंखला को एक और नया आयाम देते हुए सुहासिनी ष (एन इनिशिएटिव टु सेव द स्माइल ऑफ गर्ल चाइल्ड) की मुहिम में गोनेर क्षेत्र के बच्चों के सफल परिणाम आने पर उन्हें पुरस्कृत किया। जेईसीआरसी फाउन्डेशन का यह ग्रुप सुहासिनी समाज में प्रधानमंत्री नरेन्द्र मोदी की बेटी बचाओ बेटी पढ़ाओ की परिकल्पना के आधार पर कार्य करता है और अपनी योजना को क्रियान्वन करता है। लगातार 8 महीनों से सुहासिनी टीम के सदस्य गोनेर क्षेत्र में लड़कियों को शिक्षा उपलब्ध कराने व उन्हें एक सुरक्षित जीवन प्रदान करने के क्षेत्र में जागरूकता फैला रहे हैं। टीम की कड़ी मेहनत से गोनेर के लोगों की सोच में भी बदलाव आया है और साथ ही टीम पर विश्वास करके लोगो ने लड़कियों को पढ़ने की आजादी भी दी है। सुहासिनी ने गोनेर में अब तक 12 लड़कियों का स्कूल में दाखिला करवाया है और 35 बच्चों को फिर से स्कूल से जोड़ने में सफलता प्राप्त की है। जेईसीआरसी कालेज के डायरेक्टर अर्पित अग्रवाल ने बताया कि टीम सुहासिनी समाज में कन्याओं के प्रति बढ़ रही कुरीतियों को जड़ से हटाने के कार्य में निरन्तर प्रगतिशील है।

Page No. 5 May 09, 2017  
Powered by: erelego.com

# city भास्कर

JASPUR, TUESDAY 07/03/2017

## आज होगा वार्षिक बाल महोत्सव

**सिटी रिपोर्टर •** सीतापुरा स्थित जेईसीआरसी कैंपस में मंगलवार को कॉलेज के जरूरत ग्रुप की ओर से वार्षिक बाल महोत्सव 'जरूरत-सेलिब्रेटिंग इनोसेंस' का आयोजन किया जाएगा। कार्यक्रम में विभिन्न एनजीओ से लगभग 350 बच्चों के साथ ही कॉलेज स्टूडेंट्स भाग लेंगे। जरूरत टीम अपने योगदान को 'बिगेस्ट ओरिगेमी फ्लॉवर बास्केट' के रूप में लिम्का बुक ऑफ रिकॉर्ड्स में भी सम्मिलित कराने का प्रयास कर रही है। कार्यक्रम में पर्यावरण कार्यकर्ता पद्मभूषण चंडी प्रसाद भट्ट व वाटरमैन रमन मैग्सेसे अवॉर्ड से सम्मानित राजेंद्र सिंह भी स्टूडेंट्स से रूबरू होंगे।

10

जयपुर, बुधवार, 8 मर् 2017

जयपुर

80

दैनिक नवज्याति

## जरूरत के साथ गरीब बच्चों को संबल

**जेईसीआरसी की अगुठी पहल**

स्टूटो/नवज्याति, जयपुर

जेईसीआरसी फाउंडेशन में मंगलवार को जरूरत का छटा वार्षिकोत्सव धूमधाम से मनाया गया। इसमें गरीब बच्चों को संबल प्रदान किया गया और शिक्षा से जोड़ने का प्रयास किया गया। इस मौके पर राज्य के विभिन्न एंजीनों के 400 से अधिक बच्चे ने भाग लिया और रंगारंग कार्यक्रम के माध्यम से सभी का मनमोह किया। इन बच्चों ने राजस्थानी, फिल्मी, पंजाबी और रिनिक्स गानों पर डांस की प्रस्तुतियां दीं। इसमें पूर्व कार्यक्रम की शुरुआत मुख्य अतिथि पद्म भूषण एवं गांधीयन शांति पुरस्कार प्राप्त चंडी प्रसाद भट्ट, वाटरमैन ऑफरिडिया राजेंद्र सिंह, जेईसीआरसी के डायरेक्टर अर्पित अग्रवाल और प्रिंसिपल डॉ. वीके चांदना ने किया। इस मौके पर भट्ट ने जेईसीआरसी के विद्यार्थियों की ओर से शुरू की गई कवायद को प्रमंशा करते हुए जल और पर्यावरण संरक्षण करने की बात कही। साथ ही राजेन्द्र सिंह ने कहा कि पानी को लेकर विश्व में युद्ध शुरू हो गया



हे। इस मौके पर शेफाली जैन और शिवांगी शर्मा ने बच्चों को कहानियां सुनाईं और पुरस्कार बांटे।

**लिम्का बुक ऑफ रिकॉर्ड**

लिम्का बुक ऑफ रिकॉर्ड के अंतर्गत जरूरत के बच्चों द्वारा 25000 फूलों का बिगेस्ट और गनी फ्लॉवर बास्केट के विषय वस्तु पर सजाया गया। जेईसीआरसी के डायरेक्टर अर्पित अग्रवाल ने बच्चों का हीमला बढ़ाया और कहा कि नोबेल शांति पुरस्कार प्राप्त वैजलाश सत्याधी से प्रेरित होकर विद्यार्थियों द्वारा समाज की बेहतरी में उठाया गया एक सराहनीय कदम है।

Abhyuday 2016-17





Alumni meet 2016-17



Renaissance 2016-17



Accenture Women's Day 2016-17



Induction Day 2016-17



**लड़कियों के लिए 'डायवर्सिटी कैम्प'**

सीतापुरा स्थित जेईसीआरसी कॉलेज में खास तौर पर लड़कियों के लिए माइक्रोसॉफ्ट के द्वारा आयोजित 'डायवर्सिटी कैम्प' का आयोजन किया गया जिसके तहत माइक्रोसॉफ्ट की सीनियर डायरेक्टर ऐनी मैथ्यू ने इस कैम्प को सम्बोधित किया, साथ ही फिजिकली डिसेबल्ड छात्रों के लिए भी माइक्रोसॉफ्ट के द्वारा एक 'एक्सेसिबिलिटी कैम्प' का भी आयोजन किया गया। कार्यक्रम की शुरुआत आए हुए अतिथियों माइक्रोसॉफ्ट सीनियर डायरेक्टर ऐनी मैथ्यू, माइक्रोसॉफ्ट एकेडमी इनिशिएटिव हैड वैकटेश सर्वसिद्धि, एमए.पी इंडिया प्रोग्राम मैनेजर विभोर श्रीवास्तव, जेईसीआरसी कॉलेज के डायरेक्टर अर्पित अग्रवाल, वाइस चेयरमैन एल.एल. शर्मा, डायरेक्टर सोशल इनिशिएटिव ओ.पी. जैन, वरिष्ठ सलाहकार पी.के. तिवारी और कॉलेज के प्रिंसिपल प्रो. डॉ. विनय कुमार चांदना की उपस्थिति में दीप प्रज्ज्वलन के साथ हुआ। कार्यक्रम में राजस्थान के 17 विभिन्न कॉलेजों से 300 से अधिक विभिन्न संकायों की बालिका छात्राओं ने अपनी उपस्थिति दर्ज कराई और माइक्रोसॉफ्ट के द्वारा चलाए जा रहे डायवर्सिटी कैम्प में टेक्नोलॉजी के बारे में जानकारी प्राप्त की।



Annie Mathew visited JECRC

**स्टूडेंट्स ने बढ़-चढ़ कर किया रक्तदान**

डेली न्यूज़, mix रिपोर्टर, जयपुर।



जेईसीआरसी फाउंडेशन में बुधवार को रक्तदान शिविर का आयोजन किया गया। जेईसीआरसी की सामाजिक सरोकार से ओत प्रोत टीम 'आशाएं द लाइफ सेवियर्स' ने रक्त की कमी के कारण किसी भी जिंदगी न जाने देने का संकल्प लिया और जयपुर के विभिन्न अस्पतालों में आपातकालीन स्थिति के समय सिंगल डोनर प्लेटलेट्स दान एवं रक्त दान के लिए सदैव तत्पर रहते हैं एवं पिछले चार वर्षों में 1000 से अधिक जीवन बचाने में सफल भी रहे हैं। विगत 10 वर्षों से जेईसीआरसी परिसर में रक्तदान शिविर का आयोजन सतत रूप से होता आ रहा है, इसके माध्यम से 11287 यूनिट रक्तदान किया जा चुका है। पिछले वर्ष एकत्र हुए रक्त को भारतीय सेनानियों को समर्पित किया गया था। इस अवसर पर जेईसीआरसी के इस प्रयास की साहना करने और देश के लिए रक्तदान का जज्बा रखने वाले स्टूडेंट्स का हौसला बढ़ाने के लिए मेजर जनरल अरुण माथुर ने सर्वप्रथम रक्तदान किया और साथ ही नेशनल हेल्थ मिशन के डायरेक्टर नवीन जैन, एमएनआईटी के डायरेक्टर उदय कुमार यरगट्टी, एसीपी ट्रेफिक आलोक मिश्रा ने भी शिविर में आकर स्टूडेंट्स का हौसला बढ़ाया।

Thu, 12 October 2017  
epaper.dailynews360.com//c/22860877



**5000 छात्रों ने नियमित रक्तदान होने के लिए संकल्प पत्र भरा**



रक्त (Blood) चिकित्सागत व्यक्तियों में रक्तदान शिविर का आयोजन किया गया। चिकित्सागत की अत्यधिक मांग में ओत प्रोत टीम अलग-अलग अस्पतालों में रक्त की कमी के कारण किसी भी जिंदगी न जाने देने का संकल्प लिया और जयपुर के विभिन्न अस्पतालों में आपातकालीन स्थिति के समय सिंगल डोनर प्लेटलेट्स दान एवं रक्त दान के लिए सदैव तत्पर रहते हैं एवं पिछले चार वर्षों में 1000 से अधिक जीवन बचाने में सफल भी रहे हैं। विगत 10 वर्षों से जेईसीआरसी परिसर में रक्तदान शिविर का आयोजन सतत रूप से होता आ रहा है, इसके माध्यम से 11287 यूनिट रक्तदान किया जा चुका है। पिछले वर्ष एकत्र हुए रक्त को भारतीय सेनानियों को समर्पित किया गया था। इस अवसर पर जेईसीआरसी के इस प्रयास की साहना करने और देश के लिए रक्तदान का जज्बा रखने वाले स्टूडेंट्स का हौसला बढ़ाने के लिए मेजर जनरल अरुण माथुर ने सर्वप्रथम रक्तदान किया और साथ ही नेशनल हेल्थ मिशन के डायरेक्टर नवीन जैन, एमएनआईटी के डायरेक्टर उदय कुमार यरगट्टी, एसीपी ट्रेफिक आलोक मिश्रा ने भी शिविर में आकर स्टूडेंट्स का हौसला बढ़ाया।

छात्रों ने बढ़-चढ़ कर किया रक्तदान शिविर का आयोजन किया गया। चिकित्सागत की अत्यधिक मांग में ओत प्रोत टीम अलग-अलग अस्पतालों में रक्त की कमी के कारण किसी भी जिंदगी न जाने देने का संकल्प लिया और जयपुर के विभिन्न अस्पतालों में आपातकालीन स्थिति के समय सिंगल डोनर प्लेटलेट्स दान एवं रक्त दान के लिए सदैव तत्पर रहते हैं एवं पिछले चार वर्षों में 1000 से अधिक जीवन बचाने में सफल भी रहे हैं। विगत 10 वर्षों से जेईसीआरसी परिसर में रक्तदान शिविर का आयोजन सतत रूप से होता आ रहा है, इसके माध्यम से 11287 यूनिट रक्तदान किया जा चुका है। पिछले वर्ष एकत्र हुए रक्त को भारतीय सेनानियों को समर्पित किया गया था। इस अवसर पर जेईसीआरसी के इस प्रयास की साहना करने और देश के लिए रक्तदान का जज्बा रखने वाले स्टूडेंट्स का हौसला बढ़ाने के लिए मेजर जनरल अरुण माथुर ने सर्वप्रथम रक्तदान किया और साथ ही नेशनल हेल्थ मिशन के डायरेक्टर नवीन जैन, एमएनआईटी के डायरेक्टर उदय कुमार यरगट्टी, एसीपी ट्रेफिक आलोक मिश्रा ने भी शिविर में आकर स्टूडेंट्स का हौसला बढ़ाया।

Page No. 7 Oct 12, 2017  
Powered by: anagp.com

**Blood donation drive 2017-18**



**Spiritual Cell Inauguration 2017-18**



**Sports Activities 2017-18**



Engineer's Day 2017-2018



### टेक्नो क्विज, पोस्टर मेकिंग और टैलेंट हंट में दिखाया हुनर



जयपुर | जेईसीआरसी में शुक्रवार को इंजीनियर दिवस मनाया गया। इस अवसर पर इंजीनियरिंग की सभी विधाओं में कार्यक्रमों का आयोजन किया गया। इंजीनियर दिवस पर खास तौर से विधिल इंजीनियरिंग विभाग द्वारा टेक्नो क्विज, पोस्टर मेकिंग और टैलेंट हंट की प्रतियोगिताओं का आयोजन किया गया, इफॉर्मेशन टेक्नोलॉजी विभाग के द्वारा लेन गेमिंग और टेक्नीकल क्विज की प्रतियोगिताएं रखी गईं।

Engineer's Day 2017-2018



Swacchata Pakhwada" celebrated, Cleanliness raised



Seminar on entertainment industry by alumnus

काँग्रेस राजस्थान टेक्निकल युनिवर्सिटी के प्रो. जइस चंवरलर प्रो. राजीव गुप्ता ने कहा...

# टेक्निकल कॉलेजों में फ्री मिलेगा वाई-फाई

डेली न्यूज, 18 फरवरी

जयपुर। टेक्निकल एजुकेशन में फ्री वाइफाई रिचार्ज, डाटाकार्ड, एक्सासर्ट रिफिलिंग और स्टूडेंट्स तक और आसानी से प्राप्त होगा। इसके लिए राजस्थान टेक्निकल युनिवर्सिटी (आरटीयू) कोटा जल्द ही प्रदेश के सभी कॉलेजों के पास वाई-फाई बनाने का प्लान है। इसमें स्टूडेंट्स को फ्री वाई-फाई कनेक्टिविटी मिलेगी। वे इंटरनेट सर्फिंग कर अपने फोन में डाटा हर खबर पर भरोसा रख सकेंगे। चंवरलर को सोमवार विचार गोष्ठीआयोजित करने में इंटरनेट कनेक्शन के दौरान आरटीयू के प्रो. जइस चंवरलर प्रो. राजीव गुप्ता ने जानकारी दी। उन्होंने कहा कि वाई-फाई कनेक्शन के जरूरत को ध्यान में रखते हुए राज्य में 367 कॉलेजों में फ्री वाइफाई कनेक्शन के लिए प्लान है। इसमें स्टूडेंट्स को 20 एम्पी से 1 गीबी तक डाटा देना मिलेगा।

**काँग्रेस में 367 रिचार्ज पोस्ट राखिए**

वे विदेशी कॉलेजों में इंटरनेट के साथ कनेक्शन, ऑफिस, अस्पिटल, एजुकेशन, वाइफाई, इंटरनेट और डाटाकार्ड को 367 रिचार्ज पोस्ट राखिए हुए हैं। इन्हें कनेक्शन देना आसानी से मिलेगा। चंवरलर अतिरिक्त जानकारी के लिए चंवरलर प्रो. राजीव गुप्ता से संपर्क करें। चंवरलर ने कहा कि इंटरनेट कनेक्शन के लिए प्लान है। इसमें स्टूडेंट्स को 20 एम्पी से 1 गीबी तक डाटा देना मिलेगा।

**टेक्नोलॉजी से पता चलेगी पेटिंग की पहचान**

ये डिजिटल कॉलेजों में 'प्रॉबिंग टूल्स इन एक्सपर्ट एप्लीकेशन फॉर सिम्युलेशन' शुरू हुईं। इसमें पहले दिन केवल दो कॉलेजों को फ्री वाइफाई और एक्सासर्ट के प्रो. चंवरलर को फ्री वाइफाई एप्लीकेशन पर सही में पता है, केवल दो अर्थ में जाना जाता है। एजुकेशन में डिजिटल अर्थ पर सही में पता पर काम हो रहा है। हम पेटिंग को देखकर उसकी पहचान करने वाले टेक्नोलॉजी पर काम कर रहे हैं। विचार नेचर इंटरनेट के फ्री वाइफाई कनेक्शन से पता है। एजुकेशन में रिचार्ज पोस्ट 2020 तक इंटरनेट में 5जी टेक्नोलॉजी आ जाएगी। इंटरनेट कनेक्शन से पता चलेगा कि वाई-फाई कनेक्शन को फ्री वाइफाई के प्रो. राजीव गुप्ता, अस्पिटल के प्रो. राजीव गुप्ता, अस्पिटल के प्रो. राजीव गुप्ता के प्रो. राजीव गुप्ता के अलावा प्रो. राजीव गुप्ता ने स्टूडेंट्स से इंटरनेट किया।

Sun, 18 February 2018  
 www.dailynews360.com/c/26378634

An invited Talk on "Society and control system" by vice chancellor RTU Kota



69<sup>th</sup> Republic Day Celebration



Blood Donation Camp 2017-18



Raily for Rivers 2017-18



### आज होगा वार्षिक बाल महोत्सव

सिटी रिपोर्टर • सीतापुरा स्थित जेईसीआरसी कैंपस में मंगलवार को कॉलेज के जरूरत ग्रुप की ओर से वार्षिक बाल महोत्सव 'जरूरत-सेलिब्रेटिंग इनोवेंस' का आयोजन किया जाएगा। कार्यक्रम में विभिन्न एनजीओ से लगभग 350 बच्चों के साथ ही कॉलेज स्टूडेंट्स भाग लेंगे। जरूरत टीम अपने योगदान को 'विगेस्ट ओरिगेमी फ्लॉवर बास्केट' के रूप में लिफ्टका बुक ऑफ रिकॉर्ड्स में भी सम्मिलित कराने का प्रयास कर रही है। कार्यक्रम में पर्यावरण कार्यकर्ता पंचभूषण चंडी प्रसाद भट्ट व वाटरमैन रमन मैग्सेसे अवॉर्ड से सम्मानित राजेंद्र सिंह भी स्टूडेंट्स से रूबरू होंगे।

### जरूरत के साथ गरीब बच्चों को संबल

सिटी रिपोर्टर • सीतापुरा स्थित जेईसीआरसी कैंपस में मंगलवार को कॉलेज के जरूरत ग्रुप की ओर से वार्षिक बाल महोत्सव 'जरूरत-सेलिब्रेटिंग इनोवेंस' का आयोजन किया जाएगा। कार्यक्रम में विभिन्न एनजीओ से लगभग 350 बच्चों के साथ ही कॉलेज स्टूडेंट्स भाग लेंगे। जरूरत टीम अपने योगदान को 'विगेस्ट ओरिगेमी फ्लॉवर बास्केट' के रूप में लिफ्टका बुक ऑफ रिकॉर्ड्स में भी सम्मिलित कराने का प्रयास कर रही है। कार्यक्रम में पर्यावरण कार्यकर्ता पंचभूषण चंडी प्रसाद भट्ट व वाटरमैन रमन मैग्सेसे अवॉर्ड से सम्मानित राजेंद्र सिंह भी स्टूडेंट्स से रूबरू होंगे।

Social group activity by Abhyuday group-Zarurat 2017-18

## नए स्टूडेंट्स का अभिनंदन

जयपुर • जेईसीआरसी इंजीनियरिंग कॉलेज में मंगलवार को नए शैक्षणिक सत्र 2017-18 में विद्यार्थियों का सौजन्य से अभिनंदन किया। सभी विद्यार्थियों को उनकी संबंधित क्लास, लैब, लाइब्रेरी और भी अन्य विभागों से अवगत कराया गया और साथ ही सभी

को एंटी रैंगिंग की शपथ दिलाई गई। डायरेक्टर अर्पित अग्रवाल ने नवआगत विद्यार्थियों के उज्ज्वल भविष्य की कामना के साथ शुभकामना सेंदरा दिया। वाइस चेयरमैन एमएल शर्मा ने कहा कि विद्यार्थी विषयक ज्ञान के साथ संस्कारों को भी जानें।

पत्रिका Wed, 02 August 2017  
epaper.patrika.com//c/21035002



समाचार जगत  
जयपुर

## तिलक और गुलाब के साथ किया नवागन्तुक विद्यार्थियों का स्वागत

जयपुर (आर)। जयपुर स्थित जेईसीआरसी इंजीनियरिंग कॉलेज में मंगलवार को नए शैक्षणिक सत्र 2017-18 के लिए नए हुए विद्यार्थियों का सौजन्य से अभिनंदन किया गया। डायरेक्टर अर्पित अग्रवाल ने नवआगत विद्यार्थियों के उज्ज्वल भविष्य की कामना के साथ शुभकामना सेंदरा दिया। वाइस चेयरमैन एमएल शर्मा ने कहा कि विद्यार्थी विषयक ज्ञान के साथ संस्कारों को भी जानें।



विद्यार्थियों के अभिवादन में भी कार्यक्रम परिसर एवं कॉलेज की सुविधाओं की शुरुआत की। कार्यक्रम में विद्यार्थियों को स्वस्थ रहने के लिए सलाह दी गई। वाइस चेयरमैन एमएल शर्मा ने कहा कि विद्यार्थी विषयक ज्ञान के साथ संस्कारों को भी जानें।

Page No: 7 Aug 02, 2017  
Powered by: webgo.com

## सेशन के पहले दिन स्टूडेंट्स को दिलाई एंटी रैंगिंग की शपथ



डेली न्यूज, mix रिपोर्टर

जयपुर। सीतापुर स्थित जेईसीआरसी इंजीनियरिंग कॉलेज में मंगलवार को फ्रेशर्स का सौजन्य से अभिनंदन किया। डायरेक्टर अर्पित अग्रवाल ने नवआगत विद्यार्थियों के उज्ज्वल भविष्य की कामना के साथ शुभकामना सेंदरा दिया। वाइस चेयरमैन एमएल शर्मा ने कहा कि विद्यार्थी विषयक ज्ञान के साथ संस्कारों को भी जानें।

इंस्टीट्यूट की ओर से चलाए जाने वाले सभी सामाजिक सरोकारों से संबंधित कार्यक्रमों की विस्तृत जानकारी स्टूडेंट्स को दी गई। कॉलेज के डायरेक्टर अर्पित अग्रवाल ने नवआगत स्टूडेंट्स को उज्ज्वल भविष्य के लिए शुभकामनाएं दी। कार्यक्रम में वाइस चेयरमैन एमएल शर्मा ने स्टूडेंट्स को स्वस्थ रहने के लिए सलाह दी। वाइस चेयरमैन एमएल शर्मा ने कहा कि विद्यार्थी विषयक ज्ञान के साथ संस्कारों को भी जानें।

Wed, 02 August 2017  
epaper.dailynews360.com/c/21035435



### Induction Day 2017-18

# LOGO DESIGNING & PUNCHLINE writing

Come up with your own creative ideas and Win

#see you on 24th feb

**NO Registration fee**  
**Cash prize worth 1.5 lakhs**

For registration or further details contact us

	CONTACT US	FOLLOW US
	NAAMAN CHUGH : 7073748727	FACEBOOK JECRC ENVISION
	ANIRUDH : 9057862360	INSTAGRAM JECRC_ENVISION
KESHAV BHARDWAJ : 9587969096		

### Logo Designing and Punchline Writing 2017-18



Spic Mcay

**JECRC Alumni Activities**

S.No.	Name of Event	Date	Place of Event
1	Alumni v/s Faculty Cricket Match	25/03/2018	JECRC
2	Seminar on Career in Entertainment Industry	12/03/2018	JECRC
3	JECRC Alumni Startup Meet	15/02/2018	JECRC
4	Distinguished Alumni Awards	13/08/2017	JECRC
5	Renaissance17 Let's Hangout	16/03/2017	JECRC
6	Renaissance17 Cricket Match	16/03/2017	JECRC
7	Alumni Panel Discussion Second Edition	11/03/2017	JECRC
8	Career Oriented Interaction with Alumni	11/03/2017	JECRC
9	JECRC Alumni Meet	28/05/2017	Patna, Bihar
10	Reminisce-A Flash from the past	05/03/2017	JECRC
11	Interactive Session with JECRC Alumni	26/08/2017	JECRC
12	JECRC Alumni Meet	11/12/2016	Mumbai-Pune
13	Alumni Meet and Greet Session	29/09/2016	JECRC
14	JECRC Alumni Meet	17/09/2016	NewYork
15	Josh Meets	29/05/2016	JECRC
15	Alumni Treasure Hunt Alumni Panel Discussion	22/03/2016	JECRC
16	Mr. and Ms. Alumni Competition-2016	07/03/2016	E Competition
17	Let's Hangout	01/03/2016	JECRC



**Let's Hangout march 17**



**Alumni VS Faculty Cricket Match**



**Seminar on Career in Entertainment Industry**





**JECRC Alumni Startup Meet**



**Renaissance 17 Let's Hangout**



**Distinguished Alumni Awards**



**Renaissance 17 Cricket Match Faculty v/s Alumni**



**Alumni Panel Discussion**



**Career Oriented Interaction with Alumni**



JECRC University

Alumni Meet Bihar 2017



JECRC University

Alumni Meet Bihar 2017

### JECRC Alumni Meet



### JECRC Alumni Meet Mumbai-Pune

## 10. GOVERNANCE, INSTITUTIONAL SUPPORT AND FINANCIAL RESOURCES

### 10.1.1. State the Vision and Mission of the Institute

## VISION AND MISSION

### VISION

- To become a renowned centre of outcome based learning and work toward academic, professional, cultural and social enrichment in the lives of individuals and communities.

### MISSION

- Focus on evaluation of learning outcome and motivate students to inculcate research aptitude by project based learning.
- Identity based on informed perception of Indian, regional and global needs, the areas of focus and provide platform to gain knowledge and solutions.
- Offer opportunities for interaction between academia and industry.
- Develop human potential to its fullest extent so that intellectually capable and imaginatively gifted leaders can emerge in a range of professions.

  
PRINCIPAL  
Jaipur Engineering College &  
Research Center  
Tonk Road, Jaipur - 303 905



**10.1.2. Governing body, administrative setup, functions of various bodies, servicerules, procedures, recruitment and promotional policies**

2017-2018

**MEMBERS OF GOVERNING BODY**

S.No	Name	Post	Address
1	Sh. M.L. Sharma	Chairman	F-30, MAJOR SHAITAN SINGH COLONY, SHASTRI NAGAR, JAIPUR- 302016
2	Dr. Vinay Kumar Chandna	Member Secretary	E-806, Asha Deep Apartment Green Avenue, Jagatpura, Jaipur-302027
3	Dr. Umesh Kumar Pareek	Member	CTS bus stand, Sanganer, Jaipur-302019
4	Sh. Manish Jain	Member	MALVIYA NAGAR, 13/22, A, Jaipur-302017
5	Dr. Naveen Hemrajani	Invited from other University	-
6	Nominee from the AICTE	(Ex-officio)	Regional Office, Plot No. 1A, 5th Floor, Building of Directorate of Technical Education & Industrial Training, (Govt. of Punjab), Sector-36A, Chandigarh- 160036 Chandigarh
7	An industrialist /Technologist/Educationist from the Region to be nominated by the State Govt./UT.	(Ex-officio)	-
8	Nominee of the State Govt./UT.	(Ex-officio)	-
9	Dr. Rajesh Singhal, Professor	Member	RTU, Akelgarh, Rawatbhata Road, Kota
10	Indovision Services Pvt. Ltd. Authorized Huawei Network Academy Partner (HIT)	Member (Invities)	3 <sup>rd</sup> floor, Centrum Mall, Khasra Number 369, MG Road, Sultanpur, New Delhi
11	Wadhvani Operating Foundation	Member (Invities)	Four Main Street, Suite 120, Los Altos, CA 94022
12	Forsk Technologies Private Ltd.	Member (Invities)	# M-5, Software Building, IT Park, Industrial Area EPIP, Sitapura, Jaipur
13	CADD Centre Training Services Pvt. Ltd., Chennai	Member (Invities)	Local office – 106-107, Mahima Majesty, Ram Gali No. 6, Raja Park, Jaipur

  
 PRINCIPAL  
 Jaipur Engineering College &  
 Research Center  
 Tonk Road, Jaipur - 303 905

## [SELF ASSESSMENT REPORT]



### LIST OF GOVERNING COUNCIL MEMBERS FOR THE YEAR 2016-2017

S.No.	Name	Qualification	Designation
1.	Mr. Om Prakash Agrawal	B.Com., FCA	Chairman
2.	Mr. Mohan Lal Sharma	B.A. (Hons.)	Vice-Chairman
3.	Mr. Sohan Lal Agrawal	B.Com., L.L.B., CAIB, Acharya (Vastu)	Secretary
4.	Mr. Ram Avatar Jain	M.Sc.	Treasurer
5.	Mr. Amit Agrawal	B.Com	Member
6.	Mr. Arpit Agrawal	B.Com.	Member
7.	Dr. Puran Chand Agrawal	Ph.D.	Member
8.	All India Council for Technical Education, Regional Office (Ex-officio)		Nominee
9.	Rajasthan Technical University (RTU), Kota		Nominee
10.	Director, Technical Education, Government of Rajasthan (Ex-Officio)		Nominee
11.	Dr. Vinay Kumar Chandna	M.Tech., Ph.D.	Member
12.	Mr. Manish Jain	M.Tech.	Nominee
13.	Ms. Jyoti Thanvi	Ph.D.	Nominee

### LIST OF GOVERNING COUNCIL MEMBERS FOR THE YEAR 2015-2016

S.No.	Name	Qualification	Designation
1.	Mr. Om Prakash Agrawal	B.Com., FCA	Chairman
2.	Mr. Mohan Lal Sharma	B.A. (Hons.)	Vice-Chairman
3.	Mr. Sohan Lal Agrawal	B.Com., L.L.B., CAIB, Acharya (Vastu)	Secretary
4.	Mr. Ram Avatar Jain	M.Sc.	Treasurer
5.	Mr. Amit Agrawal	B.Com	Member
6.	Mr. Arpit Agrawal	B.Com.	Member
7.	Dr. Puran Chand Agrawal	Ph.D.	Member
8.	All India Council for Technical Education, Regional Office (Ex-officio)		Nominee
9.	Rajasthan Technical University (RTU), Kota		Nominee
10.	Director, Technical Education, Government of Rajasthan (Ex-Officio)		Nominee
11.	Dr. Vinay Kumar Chandna	M.Tech., Ph.D.	Member
12.	Mr. Manish Jain	M.Tech.	Nominee
13.	Ms. Jyoti Thanvi	Ph.D.	Nominee

## Functions and Responsibilities

**Chairman:** Overall Incharge of the College

**Principal:** responsible for faculty development and research activities; smooth functioning of the institute.

**Program Coordinators / HODs:** Are responsible for administration and academic activities of their program / departments.

**Dean I Year:** is responsible for administration and academic activities related to I year.

**Dean II Shift:** is responsible for administration and academic activities related to II shift.

**Maintenance Incharge:** is responsible for maintenance related issues in the campus.

**T & P Officer:** is responsible for Training and placement related activities in the Campus.

**Registrar:** Deals with admissions, registration and results of students and all other issues related to students and the Rajasthan Technical University.

**Accounts:** All issues related to student fees, budget and payment.

**Establishment:** Deals with all issues related to staff recruitment, increments, promotions, provident fund, gratuity and salary bills etc.

**Financial Power Deligation to the Program Coordinators/HODs** – impress amount of Rs. 10,000/- is sanctioned to the all Program Coordinators/HODs and on submission of account further amount is dispursed.



PRINCIPAL  
Jaipur Engineering College &  
Hospitality  
Tosh Road, Jaipur - 302 908



# [SELF ASSESSMENT REPORT]



NATIONAL SOCIETY FOR ENGINEERING RESEARCH AND DEVELOPMENT, JAIPUR.

10-10-2015

## Delegation of powers to the various authorities

The Chairman, JECRC Foundation, and the National Society for Engineering Research and Development, has directed me to convey the delegation of powers to the various authorities working in the NSERD promoted institutions. Our Esteemed Chairman is of the view that the College Principal and the Registrar should have adequate powers so that they are in a position to comply with the requirements of the regulatory and supervising bodies, and conduct day-to-day affairs in a positive and peaceful manner, under their own authority and signatures.

With a view to ensuring smooth and unambiguous functioning of the colleges, viz., Jaipur Engineering College And Research Centre, as also JECRC UDML College of Engineering, the delegated powers / authority are detailed hereunder:

<u>Designated Authority</u>	<u>Powers delegated</u>
a) Principal	<p>i) As Head of the Institution, he shall exercise his authority for institution building. He will act as Competent Authority for all Faculty Members and Officer staff and be responsible for overall human resource management, their appointment, utilization, retrenchment, termination, disciplinary action, etc. He will exercise signing powers as Competent Authority.</p> <p>ii) He will act as superintendent and guide for all items of work related to AICTE, RTU (Affiliating University), UGC, MHRD, Technical Education Department GOR, State Level Fees Determination Committee, and other regulatory or higher bodies.</p> <p>iii) Establish a climate in which faculty members and the students can develop self-discipline, and promote research.</p> <p>iv) To formulate the Budget and assess the infrastructural and other requirements well in advance and get the same approved from the Secretary, NSERD before execution.</p> <p>v) Impress amount of Rs. 1,00,000/- (Rs. One Lakh Only) is also delegated for routine exercise.</p>
b) Registrar	<p>a) He shall act Competent Authority for all office and sub-staff, and exercise signing powers as competent authority for their appointment, utilization, retrenchment, termination, disciplinary action, etc.</p> <p>b) He shall act as <b>Compliance Officer</b> to fulfill the regulatory guidelines etc. of AICTE, RTU (Affiliating University), UGC, MHRD, Technical Education Department GOR, State Level Fees Determination Committee, and other regulatory or higher bodies. He shall act as</p>

1



	signing authority in all such matters. c) The Registrar shall be the custodian of records and property of the college, and be directly responsible to the Director/Principal of the College for the proper discharge of his duties and functions, and exercise such other powers and perform such other duties as may be assigned to him by the Director/Principal. d) <b>In the absence of Director / Principal, all powers shall vest in Registrar and he shall exercise the authority and signing powers of the Principal including Competent Authority for Faculty Members, etc.</b>

2. This Delegation of Powers will take place with immediate effect.
3. With a view to explaining these powers and clarifying the doubts, if any, a meeting will be held shortly, for which I am directed to request (1) Shri Amit Agrawal (2) Shri Arpit Agrawal (3) Shri M.L. Sharma, Principals and Registrars of both the colleges to attend the said meeting. Convenient date, time and venue of the meeting shall be communicated separately.
4. The concerned Principals and Registrars are requested to note the Delegation of Powers and acknowledge receipt.

By Order,

S.L. Agrawal  
Executive Director  
JECRC Foundation  
Jaipur.



Dated : 12<sup>th</sup> June 2015.

# [SELF ASSESSMENT REPORT]



## Frequency of the Meetings

### Jaipur Engineering College & Research Centre

From : Principal Office	To : All BOG Members
-------------------------	----------------------

Noting Reference No. JECRC/02/2017-18

04/05/18

#### Call of Meeting

Venue: Board Room, Block A

Date & Time May 19, 2018 at 11:00 AM

#### Agenda:

1. Confirmation of minutes of the last meeting during 2015-16
2. Annual report of the College for the academic year 2016-17
3. Annual report of the College for the academic year 2017-18
4. Proposed activities for the new academic year 2018-19
5. Any other issues with the permission of the Chair

#### Members:

S. No	Name	Post	Address
1	Sh. M.L. Sharma	Chairman	F-30, Major Shaitan Singh Colony, Shastri Nagar, Jaipur- 302016
2	Dr. Vinay Kumar Chandna	Member Secretary	E-806, Asha Deep Apartment Green Avenue, Jagatpura, Jaipur-302027
3	Dr. Umesh Kumar Pareek	Member	CTS bus stand, Sanganer, Jaipur-302019
4	Sh. Manish Jain	Member	Malviya Nagar, 13/22, A, Jaipur-302017
5	Dr. Naveen Hemrajani	Invited from other University	
6	Nominee from the AICTE	(Ex-officio)	Regional Office, Plot No. 1A, 5th Floor, Building of Directorate of Technical Education & Industrial Training, (Govt. of Punjab), Sector-36A, Chandigarh
7	An industrialist/ Technologist / Educationist from the Region to be nominated by the State Govt./UT.	(Ex-officio)	
8	Nominee of the State Govt./UT.	(Ex-officio)	
9	Dr. Rajesh Singhal, Professor	Member	RTU, Akelgarh, Rawatbhata Road, Kota
10	Indovision Services Pvt. Ltd, Authorized Huawei Network Academy Partner (HIT)	Member (Invities)	3 <sup>rd</sup> floor, Centrum Mall, Khasra Number 369, MG Road, Sultanpur, New Delhi
11	Wadhvani Operating Foundation	Member (Invities)	Four Main Street, Suite 120, Los Altos, CA 94022
12	Forsk Technologies Private Ltd.	Member (Invities)	# M-5, Software Building, IT Park, Industrial Area EPIP, Sitapura, Jaipur
13	CADD Centre Training Services Pvt. Ltd., Chennai	Member (Invities)	Local office – 106-107, Mahima Majesty, Ram Gali No. 6, Raja Park, Jaipur

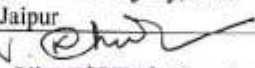
  
Dr. Vinay Kumar Chandna  
Jaipur Engineering College & Research Centre  
Tonk Road, Jaipur 303 805

## MINUTES OF MEETING

Last meeting of BOG was held on 22/06/2016 in the board room of the College. Following are the action taken on the meeting –

1. Graduate Attributes are shared with all concerned Program Coordinators, HODs, Dean I Year, Dean II Shift
2. Shortcomings related to placements were taken care of and accordingly tie-ups made with external agencies for preparation for the placements.
3. Government job cell was formed with an aim to guide for Government related jobs, preparation for GATE, other competitive examinations etc.
4. A placement team has been formed for the placement of students who are not eligible (i.e. they have cleared their degree with back) for the placement. This team is working with a nomenclature of Outreach placement cell with a motto to place such non eligible students.
5. Internal Quality Assessment measure has been taken care of viz., the course outcome analysis, gap analysis, content beyond syllabus, lab maintenance, publication, co-curricular activities, moderation of internal papers etc.
6. Initiation is taken to establish relation with the industry, in view of the same students are undergoing for training in different areas. MoUs are signed with the industries.
7. Activities related to social initiatives were taken care of.
8. The related documents submitted to RTU
9. As per RTU the QIV points were made available for the year 2016-17 were 616/1000.
  - a. The corrective measures were taken on the same and for the year 2017-18 and the documents were again sent to RTU Kota for inspection.
  - b. On the basis of documents the points will be awarded by RTU and significant improvement has been reported.
  - c. Further, the departments are working on outcome based education and the letter related to content beyond syllabus is sent to the University.

V. P. Singh  
PRINCIPAL  
Jaipur Engineering College &  
Research Center.  
Tonk Road, Jaipur - 303 905

# [SELF ASSESSMENT REPORT]



## Minutes of the meetings

Jaipur Engineering College & Research Centre

From : Principal Office

To : All BOG Members

Noting Reference No. JECRC/02/2017-18/238

25/04/18

### Annual Board of Governance Meeting Notice

Academic year 2017-18 is almost over and the new academic year 2018-19 is commencing from July 02, 2018. There is a meeting on May 30, 2018 at 11:00 AM in the Board room of College campus to discuss the following agenda items –

1. Confirmation of minutes of the last meeting
2. Annual report of the College for the academic year 2017-18
3. Proposed activities for the new academic year 2018-19
4. Any other issues with the permission of the Chair

All are requested to be present in the meeting.

*V. Par*

PRINCIPAL

PRINCIPAL

Jaipur Engineering College &  
Research Center

.Tonk Road, Jaipur - 303 905

Copy to –

1. Shri M.L. Sharma, Chairman
2. Dr. Vinay Kumar Chandna, Member Secretary
3. Dr. Umesh Kumar Pareek, Member
4. Shri Manish Jain, Member
5. Dr. Naveen Hemrajani, Member
6. The Hon'ble Vice Chancellor, RTU Kota
7. The Member Secretary, AICTE, New Delhi
8. Indovision Services Pvt. Ltd. Authorized Huawei Network Academy Partner (HIT)
9. Wadhvani Operating Foundation
10. Forsk Technology Private Ltd.
11. CADD Centre Training Services Pvt. Ltd. Chennai

# [SELF ASSESSMENT REPORT]



Jaipur Engineering College & Research Centre

From : Principal Office

To : All Program Coordinators/HODs

Noting Reference No. JECRC/02/2017-18/269

29/05/18

## Minutes of the Meeting

**Venue :** Board Room – Block A

**Date & Time** Wednesday; May 30, 2018 at 11:00 AM

### **Agenda**

1. Confirmation of minutes of the last meeting during 2015-16 -
2. Annual report of the College for the academic year 2016-17
3. Annual report of the College for the academic year 2017-18
4. Proposed activities for the new academic year 2018-19
5. Any other issues with the permission of the Chair

### **Special invited Guest:**

1. Shri Amit Agrawal, Special invited Guest

### **Members Present:**

1. Shri M.L. Sharma, Chairman
2. Prof. (Dr.) V.K. Chandna, Member Secretary
3. Shri Manish Jain, Member
4. Dr. Umesh Kumar Pareek, Member
5. Dr. Naveen Hemrajani, Invited from other University
6. Dr. Sylvester Fernandes, Member (Invitees)
7. Shri Rajeev Bhargava, Member (Invitees)

### **Members absent:**

1. Dr. Rajesh Singhal, Member (RTU Kota)
2. Nominee from the AICTE
3. Nominee of the state Govt./UT.
4. An Industrialist nominated by the State Govt. ✓
5. Shri Deepak Motwani, Member (Invitees) ✓
6. Shri Atul Kumar, Member (Invitees)

V. (P) 29/5/18

Contd..2/-

## [SELF ASSESSMENT REPORT]



Meeting started at 11:00 AM; following items were discussed –

1. With the permission of the Chair, Dr. Vinay Kumar Chandna, Member Secretary welcomes all the dignitaries.
2. He read the last minutes of the meeting and further it was approved by the members unanimously.
3. He presents the annual report of the year 2016-17 and 2017-18, following items were discussed –
  - a. Vision and Mission of the institute
  - b. 12 points Program outcome
  - c. Decentralization of power – institute's organization chart was discussed. He informed that an amount of Rs. 10,000/- is sanctioned to all the Program Coordinators/HODs, Dean II Shift, Dean I year, all section incharges to meet out the immediate requirement of the fund. He also clears that on the submission of account further amount is disbursed.
  - d. Students' result analysis
  - e. For the placement data; it was made clear that placement percentage is based on unique offers. The data of higher education, engaged with family business, startups etc. will be included later.
  - f. Nine MoUs at National level and two MoUs at International level were signed to enhance the students' technical knowledge as per the market requirements. Shri Rajeev Bhargava suggested that we should adopt a process in which these certified courses should be validated by the MSME / University. These certificate courses may be examined by the university if possible it can be from JECRC University. Member secretary has noted the same for further action.
  - g. Content beyond syllabus was discussed. Shri Manish Jain informed the members about the duration of the course. Member secretary informed that these courses are running after the college hours. Students are taking interest in these courses.
  - h. Research Grants from the Govt. agencies and also proposed FDP/workshop/Seminar during the 2018-19 was discussed in brief. Member secretary informed that proposal of approx. 70 lacs were submitted to the Govt. agencies for conducting the different activities.
  - i. Budget and expenditure discussed in brief. Member secretary made clear that "other than R&D" means academic activities, it is not included research related activities. Shri Amit ji appreciated the R&D activities he pointed out that in the year 2015-16 budget was Rs. 2,50,000/- and in the year 2018-19 (proposed) it rose to Rs. 20,00,000/- it shows that students are taking interest in R&D activities.
  - j. QIV rating 2016-17 and 2017-18 was discussed. In the year 2016-17 the score was 616/1000 and after efforts this year it rose to 740/1000. Shri Amit Agrawal asked what is the highest marks so far, member secretary replied it will be checked out.

V. P. Chaudhary 29/1/18

## [SELF ASSESSMENT REPORT]



- k. Member secretary told that faculty members will be motivated for paper publication at international level repute journals.
  - l. Proposed activities for the coming year were discussed in brief.
4. Inputs by the industry –
- a. Dr. Silvester suggested that more budget for the students' R&D activities should be incorporated in more elaborate manner i.e. budget should be clearly mentioned R&D, transportation, other expenditure etc.
  - b. Centre of excellence should be opened 24x7.
  - c. Result oriented training program should be incorporated.
  - d. Shri Rajeev Bhargava suggested development of digital content
  - e. These types of meetings should be twice in a year.
  - f. In next meeting more representatives from the industry should be incorporated.
5. The meeting ended with a vote of thanks to the Chair.

  
Member Secretary



# [SELF ASSESSMENT REPORT]



no. JECRC/2017-10/553

date 18/5/18

To

The Hon'ble Vice Chancellor,  
Rajasthan Technical University,  
Rawatbhata Road,  
Kota.

Subject: Annual Board of Governors Meeting at JECRC Jaipur

Dear Sir,

Annual Board of Governors meeting of Jaipur Engineering College & Research Centre, Tonk Road, Jaipur is schedule on Wednesday the 30<sup>th</sup> May 2018 at 11:00 AM in the board Room Block-A, college campus.

You are requested kindly depute University representative for the Annual Board meeting.

Thank you & with regards,

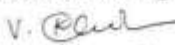
  
Dr. Vinay Kumar Chandna  
PRINCIPAL  
PRINCIPAL  
Jaipur Engineering College &  
Research Centre  
Tonk Road, Jaipur - 303 905



Jaipur Engineering College and Research Centre,  
B-10, Sector 10, Tonk Road, Jaipur  
JECRC Campus, Shri Ram 4, Nargal,  
Vikram Nagar, Opp. BPP Gate, Tonk Road, Jaipur 302 022  
t: 0141 2770120, 2770232; f: 0141 2770803; e: info@jecrcmail.com

# [SELF ASSESSMENT REPORT]



Attendance therein

## ATTENDANCE OF GOVERNING BODY MEETING

S.No	Name	Post	Signature
1	Sh. M.L. Sharma	Chairman	<i>M.L. Sharma</i>
2	Dr. Vinay Kumar Chandna	Member Secretary	<i>V. Chandna</i> 30/6/18
3	Dr. Umesh Kumar Pareek	Member	<i>U. Pareek</i> 25.6.18
4	Sh. Manish Jain	Member	<i>M. Jain</i> 3.6.18
5	Dr. Naveen Hemrajani	Invited from other University	<i>N. Hemrajani</i>
6	Nominee from the AICTE	(Ex-officio)	
7	An industrialist /Technologist/Educationist from the Region to be nominated by the State Govt./UT.	(Ex-officio)	
8	Nominee of the State Govt./UT.	(Ex-officio)	
9	Dr. Rajesh Singhal, Professor, RTU Kota	Member	
10	Indovision Services Pvt. Ltd. Authorized Huawei Network Academy Partner (HIT)	Member (Invities)	
11	Wadhvani Operating Foundation	Member (Invities)	
12	Forsk Technologies Private Ltd.	Member (Invities)	<i>Sylvester</i> DR. SYLVESTER FERNANDES
13	CADD Centre Training Services Pvt. Ltd., Chennai	Member (Invities)	<i>R. Bhargava</i> RATHEE BHARGAVA

The published rules including service rules, policies and procedures

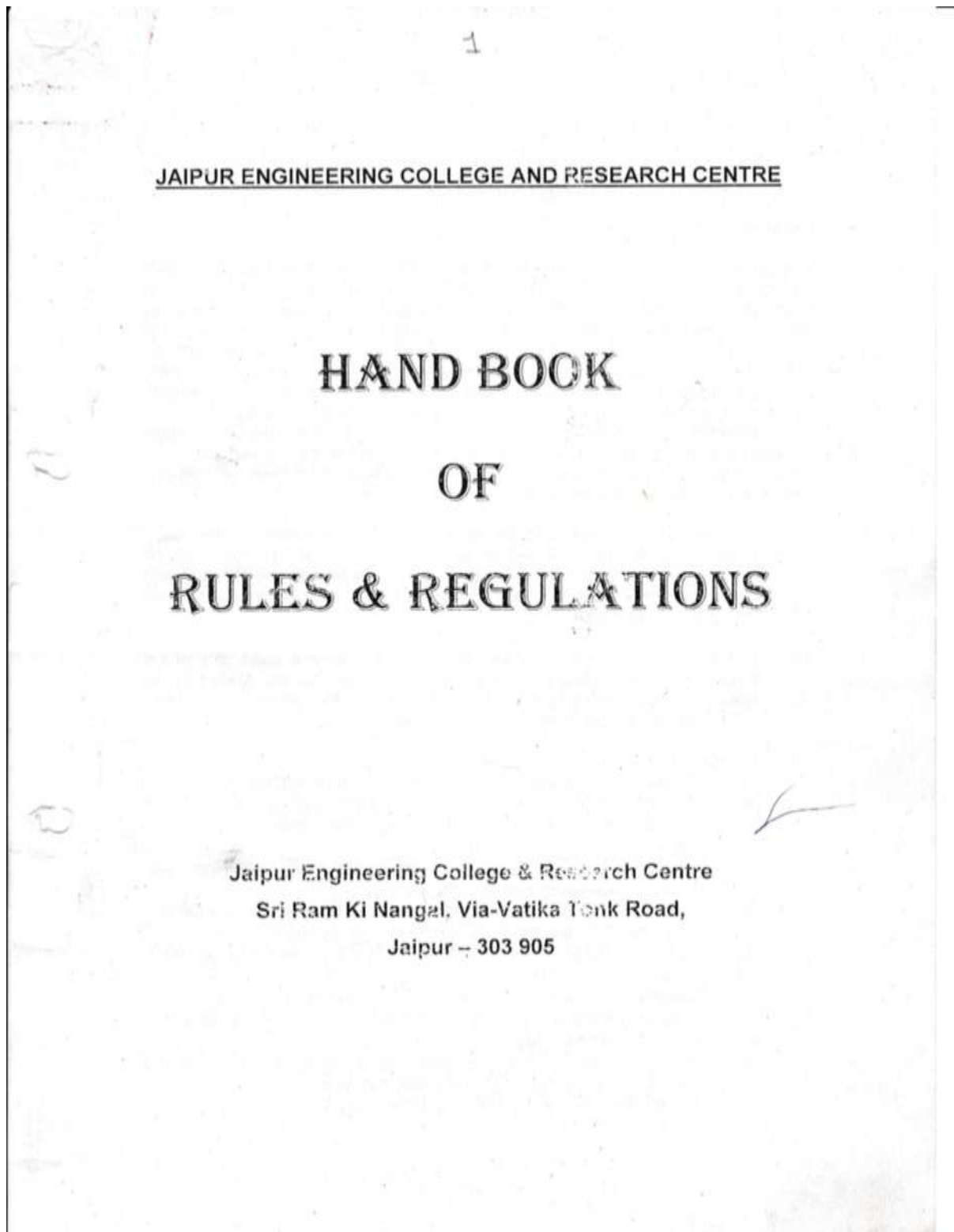

12/02/2018

## PROPOSAL FOR INCREMENT / RETENTION BENEFIT

1. It is proposed to provide 3% increment on Basic and AGP.
2. It is proposed to provide 2% DA on Basic and AGP each year. Additional DA may be announced if necessary.
3. The above proposed increment will have an impact of approximately 4% as compared to previous impact of 4.5%.
4. It is proposed to provide additional 3% increment (Basic + AGP) after completion of three years of service at JECRC under following conditions
  - a. Faculty member of Applied Science must have PhD qualification. They are given one year time for the registration and five year time for the completion of PhD there after their benefit may be considered from the date of completion certificate.
  - b. Associate Professor must have PhD qualification. They are given one year time for the registration and five year time for the completion of PhD there after their benefit may be considered from the date of completion certificate.
  - c. Assistant professor must have M.E. / M.Tech qualification. They are given one year time for the registration and three year time for the completion of M.E. / M.Tech there after their benefit may be considered from the date of completion certificate.  
AND
  - d. At least 50% students must have more than 60% marks in the theory subject's the faculty member is delivering.  
AND
  - e. Publish at least one paper in reputed conference / journal during previous year.  
AND
  - f. If someone leaves the service within one year after availing the benefit, he/she has to deposit the whole amount of benefit before leaving.
5. It is proposed to provide two increments (6%) additional increment (Basic + AGP) after completion of five, ten and fifteen years of service at JECRC (taking 1/7/17 as base month and year to all the faculty members) under following conditions
  - a. Faculty member of Applied Science must have PhD qualification. They are given one year time for the registration and five year time for the completion of PhD there after their benefit may be considered from the date of completion certificate.
  - b. Associate Professor must have PhD qualification. They are given one year time for the registration and five year time for the completion of PhD there after their benefit may be considered from the date of completion certificate.
  - c. Assistant professor must have M.E. / M.Tech qualification. They are given one year time for the registration and three year time for the completion of M.E. / M.Tech there after their benefit may be considered from the date of completion certificate.  
AND
  - d. At least 50% students must have more than 60% marks in the theory subject's the faculty member is delivering.  
AND
  - e. Publish at least one paper in reputed conference / journal.

## [SELF ASSESSMENT REPORT]



2

6. There will be additional benefit such as Mobile Number may be provided to all the HOD's, TPO's and Mentors of each semester students.
7. Faculty members who will complete Five years of service after 1/7/17 and before 31/12/ 17 may be provided retention benefit of 3% in addition to conventional increment only.
8. Assistant professors, Associate professors and Professors are provided with 5, 7, 10 days of duty leave respectively for taking examination, attending conference and any other academic assignment as assigned.
9. The faculty members who do not qualify criteria 5 for consecutive three years, retention benefits may be withdrawn.
10. Faculty member who publish a paper in a reputed conference / Journal listed in UGC approved list only will be provided 50% of the registration charges subject to a maximum of Rs. 5000/- (Five Thousand) only.
11. In case of promotion the next increment date will be the date of promotion. However, in case of any ambiguity the committee will decide the next increment date.
12. These will not be applied to non teaching staff including class IV servants.

*V. Chandna*

Dr. V. K. Chandna

OFFICE OF THE CENTRAL MONITORING COMMITTEE  
JECRC Campus, Shri Ram Ki Nangal, Via-Sitapura, Near Sanganer Sadar Thana, Tonk Road, Jaipur-302022

Promotion Policy

Under the fitment of proposal and increment retention benefit the faculty members are kept in the pay scale AGP of 6000, 7000, 8000 for Assistant Professors, 9000 AGP for Associate Professors, 10,000 AGP for Professors.

The change of AGP for one level to another AGP 6000 AGP 7000 after five years, from AGP7000, AGP 8000 after four years and from AGP 8000 to AGP 9000 after three years as per AICTE. Along with the faculty members who wish to promote to AGP 9000 must have minimum qualifications of Ph.D and must appear in front of Selection Committee for the same.

The above benefits will be applicable if the faculty member have at least 50% points out of 200 self appraisal points.

# [SELF ASSESSMENT REPORT]



## Jaipur Engineering College and Research Centre, Jaipur

FACULTY APPRAISAL FORM (Session 2018-2019)

For best faculty award

Total 200 points

Name of Faculty Member:

Department:

Designation:

S. No.	Item Name	Maximum Points	Points obtained												
1	Academic result 30 points average (90% students having more than 70% : 30 points, 80-89% students having more than 70% result: 27 points, 70-79% students having more than 70% result: 24 points, 60-69% students having more than 70% result: 21, 60-69% students having more than 60% result: 18 points, 50-59% students having more than 60% result: 15 points else ZERO) Example: <table border="1" style="margin-left: 20px;"> <tr> <td>Theory Subject</td> <td>Points obtained</td> </tr> <tr> <td>Sub-1</td> <td>30</td> </tr> <tr> <td>Sub-2</td> <td>27</td> </tr> <tr> <td>Sub-3</td> <td>0</td> </tr> <tr> <td>Sub-4</td> <td>18</td> </tr> <tr> <td>Average points scored</td> <td>75/4 i.e. 18.75</td> </tr> </table>	Theory Subject	Points obtained	Sub-1	30	Sub-2	27	Sub-3	0	Sub-4	18	Average points scored	75/4 i.e. 18.75	30	
Theory Subject	Points obtained														
Sub-1	30														
Sub-2	27														
Sub-3	0														
Sub-4	18														
Average points scored	75/4 i.e. 18.75														
	<b>No marks for Labs subjects</b>														
2	Research Publication 20 points average (1 sci indexed publication: 10 points, 1 publication having ISSN number : 5 points, Else ZERO)	20													
3	Faculty development programme 10 point average (one faculty development programme minimum 5 days attended 5 points, 2 points for attending 2 days workshop, subject to maximum of 10)	10													
4	International / National conference 10 points average ( 5 points for attending International, 3 points for attending National of repute, 2 points for National conference)	10													
5	Research grant average 20 points for having grant of more than 5 lakh, if only project submitted to DST/other govt agency: 10 points, subject to maximum 20	20													
6	Patent 10 points / Product development / startup	10													
7	New Skills / additional specialization / certification course	25													
8	Innovation in teaching learning, video lecture, online MOOCs, Online notes uploading, any other 20 points	20													
9	Technical activity organized	5													
10	Participation in social responsibility 5 points / activity subject to maximum of 10	10													
11	Institute level activity organized 5 points, participation 2 points subject to maximum of 5	5													
12	Any award received, session chair in conference, guest lecture, invited talk, etc.	5													
13	HOD recommendation maximum 30 points (Departmental responsibility 2 points, NBA related activity 5)	30													
<b>Total</b>		<b>200</b>													

Note: HOD will verify the documentary proof.

Signature of Faculty

Signature of HOD

## CHAPTER – 1

### INTRODUCTION

#### PREAMBLE:

The courses under Jaipur Engineering College & Research Centre, Jaipur (JECRC) are recognized by the AICTE. The JECRC, Jaipur is affiliated to University of Rajasthan, Jaipur. Being the affiliated institutions, the conditions of services of these institutions are normally governed by the rules framed in this respect by the AICTE/ Rajasthan University / State Government. Additionally, for academic staff the College will also be guided by the relevant rules of the AICTE. Taking this in view, the Jaipur Engineering College & Research Centre, Jaipur has framed a document, which gives the a brief idea of the conditions of service and the benefits attached to the employment etc. Further, the information given in this booklet may be subject to revision from time to time. In addition to the conditions of service, the institutes have made certain procedural guidelines to make the administration more smooth and transparent. These are also included here in this document.

- 1.1 The service conditions shall be applicable to all employees of the Jaipur Engineering College & Research Centre, Jaipur (JECRC). They may be supplemented or amended from time to time based on AICTE/ Affiliating University/ State Government rules. However, the management shall have the right to relax any of the rules.
- 1.2 For any other matters or details relevant to the service conditions of the employees, not specifically covered here, the College shall be guided by the rules, norms and procedures as prescribed by the Rajasthan Government / AICTE/ Rajasthan University from time to time.
- 1.3 Definitions:
  - (a) "Chairman" means the Chairman of the Executive Council
  - (b) "College," means the Jaipur Engineering College & Research Centre, Jaipur / any other college under the domain of Governing Council
  - (c) "Executive Council," means the Executive Body of the college
  - (d) "Funds," means the Funds of the College
  - (e) "Governing Council," means the Governing Body of the college
  - (f) "President," means the President of the Governing Council
  - (g) "Principal," means the Principal of the Jaipur Engineering College & Research Centre, Jaipur
  - (h) "Secretary," means the Secretary of the Governing Council
  - (i) "Society," means the National Society for Engineering Research and Development, Jaipur
  - (j) "Financial Year," means the year commencing from 1<sup>st</sup> April and closing on 31<sup>st</sup> March of the next calendar year.
  - (k) "University," means the affiliating University



2

- (l) Academic Year means period of academic activity from 1<sup>st</sup> July to 30<sup>th</sup> June of the next year.
- (m) "Faculty" means a teaching staff of the College
- (n) "Employee" means anybody who has been employed by the College either as 'faculty' or on any post covered under 'other staff'
- (o) "University" means Affiliating University
- (p) "Regular Employee" means the faculty or other staff appointed in the prescribed scales of the post either on probation or confirmed one.
- (q) Ad-hoc employee means appointed on ad-hoc basis for specific period either in the scale or with consolidated salary with specific conditions as shown in the appointment order.

NOTE: For teaching positions, the eligibility will be as per AICTE & the affiliating University norms.

3.

CHAPTER – 2

**APPOINTMENTS AND ITS TERMS AND CONDITIONS**

**FACULTY STAFF:**

- 2.1 There are various categories of employees at the College. Their salary scales are given separately in this document. Normally, regular appointments particularly as faculty will be made by direct selection by inviting applications through public advertisement. The required qualifications for faculty staff are generally as prescribed by the AICTE.
- 2.2 The regular employees of the institute will be eligible to the Dearness Allowance and other allowances as sanctioned by the BOG of the College from time to time.
- 2.3 The paramount consideration in the appointment or promotion of an employee shall be guided by the desired standards of efficiency, competence and integrity.
- 2.4 Selection and compensation of employees shall be made without distinction as to race, sex, or religion and the same shall be made on competitive basis.

Terms and conditions of appointment

The appointments shall be made subject to the following terms:

- 2.5 (a) The terms of appointment provide for termination by a notice on either side of one month. If anyone desires to be relieved prior to the completion of the notice period, he/she will be required to pay to the College an amount equal to his / her salary and allowances for the deficient notice period. However, the management will have the right to waive the notice period.  
  
(b) Unless waived in part or in full by the appointing authority, there will be a probationary period for three months. At the end of the probationary period, it may be extended by the appointing authority for a period upto one year. The services of an employee on probation can be terminated without notice and without assigning any reason.  
  
(c) The age of superannuation will be 70 years for the faculty and 62 years for other staff unless extended by the competent authority.  
  
Other service conditions will be generally agree with the norms and executive instructions of the AICTE / Affiliating University / Rajasthan Government and as amended by the College from time to time.
- 2.6 An employee shall not without the previous written permission of the Managing Trustee in the case of Director / Principal and in case of teaching and other staff of the Director / Principal respectively be engaged directly or

indirectly in any trade, business or occupation or any other remunerative or non-remunerative work.

2.7 Besides appointments in regular scale, the appointments of the faculty and staff may be made on fixed terms on ad-hoc or contract basis. These appointments will carry a consolidated salary or salary in the scale. Fixed term appointees are eligible for vacation and it is admissible to one who has completed minimum service of one semester. In case a fixed term appointment gets converted into a regular appointment for various terminal purposes, the continuity of service will be reckoned from the date of the commencement of the term of appointment.

2.8 Pay Scales:

(i) Normally, the pay scales of the faculty will be as per the recommendations of AICTE and as approved by the state Government.

(a) The existing structure of the scales are as under –

S. No.	Category	Pay scales
1	Lecturer	8000 – 275 – 13500
2	Senior Lecturer	10000 – 325 – 15200
3	Assistant Professor	12000 – 420 – 18300
4	Professor	16400 – 450 – 20900 – 500 – 22400

2.9 Annual increment will fall due on completion of one year of continuous service.

2.10 Incentives for Higher Qualifications - At the time of recruitment as Lecturers, advance increments may be admissible to those who hold higher degrees as under:

(a) Two increments will be admissible to those Science / Humanities teachers with M. Phil and to those technical faculty with M.E. / M.Tech.

(b) A staff will be eligible for two increments as and when he /she acquires a Ph.D. Degree in his / her service career.

2.11 Career Advancement for faculty

The promotions under Career Advancement Scheme will be as per the guidelines given below. All the promotions in career advancement will be "in-situ" basis and therefore the work allocation (teaching load, etc) may remain the same after promotion and additional responsibilities may also be assigned.

4

(C) Professor:

In addition to the sanctioned position of Professors, which must be filled in through direct recruitment through all India advertisements, promotions may be made from the post of Assistant Professor after 10 years of service as Assistant Professor. The selection committee for promotion to the post of Professor will be the same as that for direct recruitment.

Some of the desirable activities of candidates for the post of Professors will be as follows -

- (a) Research contribution: books, articles, research papers etc. published (at least four papers in journals required) The best three written contributions of the papers (as defined by her/him) may be sent in advance to the experts to review before coming for the selection. The candidate should be asked to submit these in 3 sets with the applications.
- (b) Seminars/ conferences attended: must have attended at least 4 seminars/conferences at national or international level or must have attended summer / winter schools (short-term course) of total duration of 4 weeks.
- (c) Significant contribution to teaching / academic environment / project supervision / sponsored projects / institutional corporate life etc.
- (d) Adequate extension and field outreach activities
- (e) Development of course material / monographs
- (f) Participation in continuing education programmes
- (g) Other academic and administrative contributions

2.12 Career Advancement for Faculty

- (a) Provides for movement of:
  - (i) Lecturer to Senior Lecturer (Senior Scale)
  - (ii) Senior Lecturer to Assistant Professor
- (b) Calls for promotion under Career Advancement Scheme: The candidate must have consistently satisfactory performance

**Non Faculty**

2.13 Pay Scales – qualifications of other staff.

- (i) The other staff there will be of two categories viz. (a) technical staff  
(b) administrative / ministerial staff.
- (ii) The pay scales and qualifications for different technical posts will be on par with AICTE/State Government/ University Rules.
- (iii) Similarly for administrative staff, the same will be on par with university / government rules.

Minimum length of service for eligibility to move into the grade of Senior Lecturer would be four years for those with Ph.D., five years for those with M.Phil, M.Tech and six years for others at the level of lecturer. For eligibility to move into the Grade of Assistant Professor, the minimum length of service as Senior Lecturer shall be five years.

For movement into grades of Assistant Professor and above, the minimum eligibility criterion would be Ph.D. Those without Ph.D. can go upto the level of Senior Lecturer.

An Assistant Professor with a minimum of ten years of service in that grade will be eligible to be considered for appointment as a Professor. The selection committees for Career Advancement shall be same as those for direct recruitment for each category.

The requirement of consistently satisfactory performance appraisal reports shall be the mandatory requirement for Career Advancement from Lecturer to Senior Lecturer and from Senior Lecturer to Assistant Professor.

(A) Senior Lecturer:

A lecturer will be eligible for placement in a senior scale through a procedure of selection, if she / he has:

- (i) Completed 5 years of continues service at the College. However, relaxation of one year and two years respectively, will be given to those with M.Phil, M.E. / M.Tech. and Ph.D.
- (ii) Organization of short term course/conference or research publications will be considered an additional qualification.
- (iii) Consistently shown satisfactory performance.

(B) Assistant Professor:

A senior lecturer will be eligible for promotion to the post of Asstt. Professor if she/he has:

- (i) Completed 5 years of service in the senior scale
- (ii) Obtained a Ph.D. degree or has equivalent published work.
- (iii) Made some mark in the areas of research, quality of publications, contribution to education innovation, design of new courses and curricula and extension activities.
- (iv) Organization of short term course/conference or research publications will be considered an additional qualification.
- (v) Shows consistently good performance.

Promotion to the post of Assistant Professor will be through a process of selection by a selection committee.

5

Selection Procedure

All the vacancies of faculty staff and other staff will be advertised in prominent newspapers. The selection will be done on competitive merit which shall be judged by a duly constituted selection committee.

NOTE:

The staff members of the College deputed for any training program / conferences/seminar/workshop etc. has to serve the institute at least for one year after completion of training. In case he /she resigns from the post before completion of the one year, the recovery of the salary & other expenses paid to him / her for training /deputation period would be made.

## CHAPTER – 3

### HOLIDAYS, LEAVE AND VACATIONS

#### 3.1 Holidays:

The College will observe public holidays in a calendar year as fixed by the competent authority. This will be announced at the end of the previous year.

#### 3.2 Vacations:

3.2.1 Faculty Staff are entitled to 45 days vacation in a year provided they have joined the College on or before the 1<sup>st</sup> of July. The entitlement will be worked on pro-rata basis for faculty staff joining by end of October. A faculty staff joining after October will not be entitled to any vacation during the current academic year.

3.2.2. Total vacation may be broken up in parts like (1) a week around Dipawali, (2) a week in winter and (3) the remaining in Summer.

3.2.3. For non teaching staff, the vacation entitlement in a full year is 30 days. This also may be broken up in three parts like (1) a week around Dipawali, (2) a week in winter and (3) the remaining in Summer.

#### 3.3 Leave:

3.3.1 No holidays or leave shall be claimed as a matter of right by an employee except such holidays or leave as are enforceable by law.

3.3.2 Sundays will be normally treated as holidays.

3.3.3 List of possible holidays will be announced in the beginning of the calendar year. However, at times a holiday / Sunday may be declared as a working day on need basis.

#### 3.4. Casual Leave:

3.4.1 A faculty staff shall normally be entitled to 15 days casual leave in a year on accrual basis. The accounting period is from 1<sup>st</sup> of July to 30<sup>th</sup> of June next year.

3.4.2 A non faculty staff shall normally be entitled to 12 days casual leave in a year on accrual basis. The accounting period is from 1<sup>st</sup> of July to 30<sup>th</sup> of June next year.

3.4.3 An employee can normally avail of 1 day's casual leave in a month during the probation period provided that he has at least 20 days of uninterrupted duty record at the college.

3.4.4 Sundays and holidays can be prefixed or suffixed with casual leave after a written request has been made to this effect.

3.4.5 Casual leave shall be permitted on recommendation of the in-charge (HOD) keeping in view the interests of the College / Department/ Section as the case maybe.

### 3.5 Medical Leave

3.5.1 Employees unable to carry out their regular duties due to continuous ill health (for more than 3 months) will not be permitted to continue in service.

3.5.2 Maternity leave shall be admissible to a female employee of this college for a maximum period of 60 days with the following provisions –

3.5.2.1 She is a regular employee and has served the College continuously for not less than three years.

3.5.2.2 The employee will be eligible for full pay during the leave period.

3.5.2.3 The employee shall be given 50% of the total emoluments every month during the period of her absence subject to production of maternity certificate and the balance 50% shall be provided to her in six equal monthly installments after resuming duties.

3.5.2.4 The employee under special circumstances arising out of medical complications may be permitted leave without pay for the required period.

### 3.6 Leave other than specified leave

3.6.1 Any employee absenting from duty without proper permission for 6 days will lose the benefit of salary on the following or intervening Sunday and any Holiday in continuity. He/She shall be liable to be dismissed from service if his/her absence from duty persists for 15 days in this manner.

3.6.2 Any employee who has been dismissed from service earlier but has been given employment again shall be treated as a new employee and the benefits of the earlier period of service shall automatically lapse.

### 3.7 Academic leave / duty leave

3.7.1 An employee going for attending the work entrusted by the College or for participating in a Conference etc shall be treated as on duty, provided the participation in the Conference has been approved by the College and they produce a certificate of participation on return. Some faculty staff may also be provided TA



7

& DA and the registration if any may also be reimburse depending upon the length of the service of the employee.

- 3.7.2 An employee going out of station on duty in connection with College work shall be suitably compensated for his outstation travel and stay.

CHAPTER – 4

**PROVIDENT FUND, GRATUITY**

4.1 Provident Fund

Every employee of the College shall be entitled for the benefit of Contributory Provident Fund. Some of the important salient features of the scheme are identical to EPF rules.

4.2 Employees State Insurance Scheme

Employee of the College shall be entitled for the benefit of Employees State Insurance Scheme (ESI) as per the Central Government rules.

4.3 Gratuity

The employers of the College will also be eligible for gratuity as per provision of act.

The main components of this benefit are as under:

(1) Gratuity shall be payable to an employee on the termination of his/her employment after he/she has rendered continuous service for not less than five years.

(a) on his/her superannuation or

(b) on his/her retirement or

(c) on his/her death or disablement due to accident or illness

- Provided that the completion of continuous service of five years shall not be necessary where termination of the employment of any employee is due to death or disablement.
- Provided further that in the case of death of the employee, gratuity payable to him/her shall be paid to his/her nominee, if no nomination has been made, to his/her heirs, and where any such nominees or heirs is a minor, the share of such minor shall be deposited with the controlling authority who shall invest the same for the benefit of such minor in such bank or other financial institution, as may be prescribed, until such minor attains majority.



CHAPTER – 5

**TESTING AND CONSULTANCY RULES**

The College staff shall be encouraged to take a consultancy and testing jobs from industry and others R&D agencies on payment basis. They will be permitted to use the infrastructure of the College. The consultancy / testing fee will be apportioned between the consultants and others who make a contribute to it and also to the College.

1) Remuneration to Regular Faculty & Staff:

(a) Testing:

The distribution of total income between the College and the employees will 30:70. The 70% staff distribution is as under as per the institution Rules:

1	The faculty staff	65%
2	Lab. Technician	
3	Lab. Attendant	
4	Office Staff / Administration staff involved & Dept. Clerk	5%

(b) Consultancy:

The distribution of total income between the College and the employees will 30:70 but after deducting all expenses.

30% will be retained by the College	After deducting all expenses
70% distributed amongst the concerned staff	

CHAPTER – 6

**INCENTIVE RULES**

Incentive rules have been classified into two categories. These are (i) Performance based and (ii) Time based

6.1 Based on Performance Appraisal

Period of Stay	Performance Appraisal Rating	Proposed Incentive
After Probation	Excellent	+ one increment/DA increase/BOTH
After 2 yrs	Very Good/ Excellent	+ one increment/DA increase/BOTH Conf Participation on duty leave + Registration Fee + Basic Travel (city to city)
After 3 yrs	Very Good/ Excellent	+ HRA / DA Increase / BOTH + Conf Participation on duty leave + Registration Fee + Basic Travel (city to city) + B&L + Book allowance (Rs 1000 per year) + Professional Society membership (90%) + Promotional Opportunity
After 4 yrs	Excellent	As above + Conveyance Allowance (Personal Vehicle) + Medical Allowance / Group Medical Scheme
After 5 yrs	Excellent	As above + Phone Allowance + Lap Top subsidy (80%) + Contribution to EMI for Car/Housing Loan + LTC + Education Allowance + Gratuity

**Promotional Opportunities:**

- (a) Lecturer to Sr Lecturer
- (b) Sr Lecturer to Assistant Professor
- (c) Assistant Professor to Professor

**Guidelines:**

- (a) Eligibility to be as per AICTE recommendation
- (b) Lecturer to Sr Lecturer promotion on informal appraisal
- (c) Sr Lecturer to Assistant Professor: Through a formal internal appraisal
- (d) Assistant Professor to Professor: Open Competition

**Appraisal -**

- (a) Academically Sound
- (b) Quality of Teaching (Lectures, Tutorials, Labs)
- (c) Laboratory Development
- (d) R&D

# [SELF ASSESSMENT REPORT]



- (e) Books and Manuals  
(f) Participation in other activities like (i) Placement, (ii) Student Development, (iii) Examination work, (iv) Co-curricular and ECA, (v) Contribution to College/ Industry interaction (vi) College administration ...

## 6.2 Time Based

### a. Faculty Staff

S.No.	Items	Remarks
1	Additional Increment	One additional increment in the III year if there has been no promotion / change of designation / salary revision etc.
2	Promotion	A faculty staff joining as a lecturer will be promoted to the post of a Sr. Lecturer in the sixth year if there has been no promotion / change of designation / salary revision etc. Similarly a staff member joining as a Sr. lecturer will be promoted as an Assistant Professor if there has been no promotion / change of designation / salary revision etc.
3	Conveyance	From third year: Conveyance allowance @250/- per month for staff (with salary upto Rs. 20000/- pm) and Rs. 500/- per month (for staff with salary above 20000/-pm)
4	Internet (Staff members have to ask for it)	From third year: Staff members having internet at residence in their own name can claim minimum BSNL rental
5	Conference / Short course etc.	a. Duty leave will be admissible b. After one year: registration fee will be <u>reimburse</u> c. After two years: all above and city to city travel cost will be reimbursed d. After three years: All above and subsidy towards boarding & lodging
6	HRA	To be paid @ 7.5% of basic pay from IV year
7	Book allowance (Staff members have to ask for it)	From third year : Cost of relevant books purchased by faculty to be reimbursed upto Rs. 1000/- PA
8	Education Allowance (Staff members have to ask for it)	From sixth year : 50% of tuition fee for two children. This is restricted to Rs. 500/- per month per child. This further subject to the spouse not claiming this allowance from other organization.
9	Mediclaim	Efforts are being made to cover all the staff through mediclaim policy applicable from third year onwards.

b. Other Staff (Other than faculty staff)

S.No.	Items	Remarks
1	Additional Increment	One additional increment in the III year if there has been no promotion / change of designation / salary revision etc.
2	Promotion	A staff will be promoted to the next higher post in the sixth year provided there has been no promotion / change of designation / salary revision etc. If next higher post is not existing, suitable increments may be given.
3	Conveyance	From third year: Conveyance allowance @250/- per month for staff (with salary upto Rs. 20000/- pm) and Rs. 500/- per month (for staff with salary above 20000/-pm)
4	Conference / Short course etc.	a. Duty leave will be admissible b. After one year : registration fee will be <u>reimburse</u> c. After two years : all above and city to city travel cost will be reimbursed d. After three years: All above and subsidy towards boarding & lodging
5	HRA	To be paid @ 7.5% of basic pay from IV year
6	Education Allowance	From sixth year : 50% of tuition fee for two children. This is restricted to Rs. 500/- per month per child. This further subject to the spouse not claiming this allowance from other organization.
7	Medicclaim	Efforts are being made to cover all the staff through medicclaim policy applicable from third year onwards.

12

CHAPTER – 7

**Assessment**

7.1 Performance Appraisal of Faculty:

The performance of faculty appointed on regular basis will be assessed at two stages viz (a) During Probation and (b) Confirmation

(a) During Probation:

The faculty staff will be required to submit his/her self performance appraisal one week advance of probation. The HOD will give his own observations as Reporting Officer and the Director or the Principal will review the document.

Depending upon the assessment of the staff, the staff member may be confirmed in his/her position or probation may be extended if necessary. The faculty staff will be informed of the deficiencies when the probation period is extended.

During the period of extension of the probation, the HOD will continuously observed the working of the concerned staff member and will suggest ways to improve the performance.

(b) Evaluation after Confirmation:

Even after confirmation, the performance of the faculty shall continuously be monitored on the same lines as in self assessment form. This report will be considered for the benefit to be awarded under career advancement scheme, upward promotion even by direct selection and for other incentives.

7.2 Evaluation of other Staff:

On the similar lines as for faculty, the evaluation of the other staff also will be done. However, the proforma of such evaluation will be different depending upon the nature of the post.

CHAPTER – 8

CONDUCT RULES

- 8.1 Code of conduct
- (a) Every employee shall, at all times, maintain absolute integrity and devotion to duty, and also be honest and impartial in his/her official dealings.
  - (b) An employee shall, at all times, be courteous in his/her dealings with other members of the staff, students and members of the public.
  - (c) Unless otherwise stated specifically in the terms of appointment, every employee is a full time employee of the institute. He/She may be called upon to perform such duties, as may be assigned to him/her by the competent authority beyond scheduled working hours and on holidays and Sundays. These duties shall, inter-alia, include attendance at meetings of committees to which he/she may be appointed by the College or any of its authorities.
  - (d) An employee shall observe the scheduled hours of work during which he/she must be present at the place of his/her duty.
  - (e) Except for valid reasons and/or unforeseen contingencies, no employee shall be absent from duty without prior permission.
- 8.2 No employee shall, in any radio broadcast or in any document published anonymously or in his/her own name or any other person or in any communication to the press or in any public utterance, make any statement of fact or opinion which has the effect of an adverse criticism of the College.
- 8.3 No employee shall pass any confidential information of the College to any unauthorized person or agency.
- 8.4 No employee of the institute shall, engage, directly or indirectly, in any trade or business or any private tuition or undertake any employment outside his/her official assignments.
- 8.5 An employee who gets involved in some criminal proceedings shall immediately inform the competent authority through the Head of the Department to which he/she is attached, irrespective of the fact whether he/she has been released on bail or not. An employee who is detained in police custody, whether on criminal charge or otherwise, for a period longer than forty eight hours shall not join his/her duties in the College unless he/she has obtained written permission to that effect from the competent authority.
- 8.6 No employee shall, except with the previous sanction of the competent authority, have recourse to any Court of Law or to the press for the indication of any official act which has been the subject matter of adverse criticism or an act of defamatory character. Provided nothing in this rule shall be deemed to prohibit an employee from vindicating his/her private character or any act done by him/her in his/her private capacity.
- 8.7 (a) Whenever an employee wishes to put forth any claim, or seeks redressal of any grievance or of any wrong done to him/her, he/she must forward his/her



case through proper channel, and shall not forward advance copies of his/her application to any higher authority, unless the lower authority has rejected the claim, or refused relief or the disposal of the matter is unduly delayed.

(b) No employee shall be signatory to any joint representation addressed to the authorities for redressal of any grievance or of any other matter.

8.8 An employee shall, regarding imposition of penalties for breach of any of these rules and regarding preference of appeals against any action taken against him/her, be governed by the rules made in this behalf from time to time by the competent authority.

8.9 A faculty staff shall be responsible for the results of the students of the class being engaged by him/her.

This will necessarily mean:

- a) Planning the course of lectures for the entire semester and suggesting suitable text and reference books to the students.
- b) Delivering well prepared lectures with the help of handouts and teaching aids.
- c) Preparing tutorial sheets with representative problems.
- d) Keeping an up-to-date account of attendance of students
- e) Conducting assessment of students as per the approved policies
- f) Explaining the steps taken to improve the situation / difficulty being faced in performing the duties and offering suggestions, if any, to improve the efficiency.
- g) The department will prepare an academic calendar for the department in conformity with the College calendar. The faculty staff will be following this calendar.
- h) Punctuality in arriving at the college, engaging classes shall be an important trait of a faculty staff.
- i) Faculty staff shall generally be available to students for discussion and guidance during college hours. The day's work of making attendance, checking answer books and entering and submitting marks and other details shall be completed before he/she leaves the college.
- j) The faculty staff shall regularly intimate the tutor guardians of the progress of the students. The tutor guardian, in turn, shall call the

14

students and try to find out the reasons for poor performance and deficiency in attendance. If necessary the tutor guardian shall inform the parents about the performance of the student and shall also maintain a record of the same.

8.10 Dress Code:

1. Male Staff – Should preferably wear shirts (no T-shirts) and Trousers (no Jeans). Ties also may be worn.
2. Female Staff – Should wear sarees.

**N.B.**

(This Hand Book contains guidelines for smooth functioning of the institute. These are guidelines and should not be interpreted as rules and hence can not be challenged in the Court of Law)

\*\*\*\*\*

10.1.3. Decentralization in working and grievance redressal mechanism

**HEAD OF ACADEMIC PROGRAM /  
DEPARTMENTS AND ADMINISTRATION**

<b>Program/Department/Section</b>	<b>Head</b>
Principal	Prof. (Dr.) Vinay Kumar Chandna
Dean II Shift	Dr. M.P. Singh
Dean – I Year	Prof. Umesh K. Pareek
Dy. Dean – I Year	Dr. Rekha Mithal
Civil Engineering	Ms. Monika Sharma
Computer Science & Engineering	Dr. Bhavna Sharma
Electrical Engineering	Dr. Sandeep Vyas
Electronics & Communication Engineering	Dr. Lokesh Bansal
Mechanical Engineering	Dr. M.P. Singh
Information Technology	Shri Sunil Jangir
Physics	Dr. R.K. Mangal
Chemistry	Dr. Barkha Srivastava
Mathematics	Dr. Ruchi Mathur
English & Humanities	Dr. Mukul Sharma
<b>Management &amp; Administration</b>	
Vice Chairman	Shri M.L. Sharma
Senior Advisor	Shri O.P. Jain
Senior Advisor	Shri P.K. Tiwari
Senior Advisor	Prof. S.N. Gupta
Chief Administrator Officer	Shri P.K. Gupta
Registrar	Prof. (Dr.) Anurakt Williamson
Librarian	Dr. Anita Jain
Sports Officer	Dr. Rajesh Sharma
Chief Hostel Warden	Shri P.K. Gupta
OS Office	Shri Amitabh Gupta
Accounts Officer	Shri Sumit Agarwal Shri Sandesh Pathak

**Management committee:**

Shri O.P. Agrawal	Chairman
Shri M.L. Sharma	Vice Chairman
Shri Amit Agrawal	Director
Shri Arpit Agrawal	Director

## DECENTRALIZATION OF POWER

In the institute power are transferred from Chairman to the lower level, it can be seen in the organization chart.

### Organization Chart

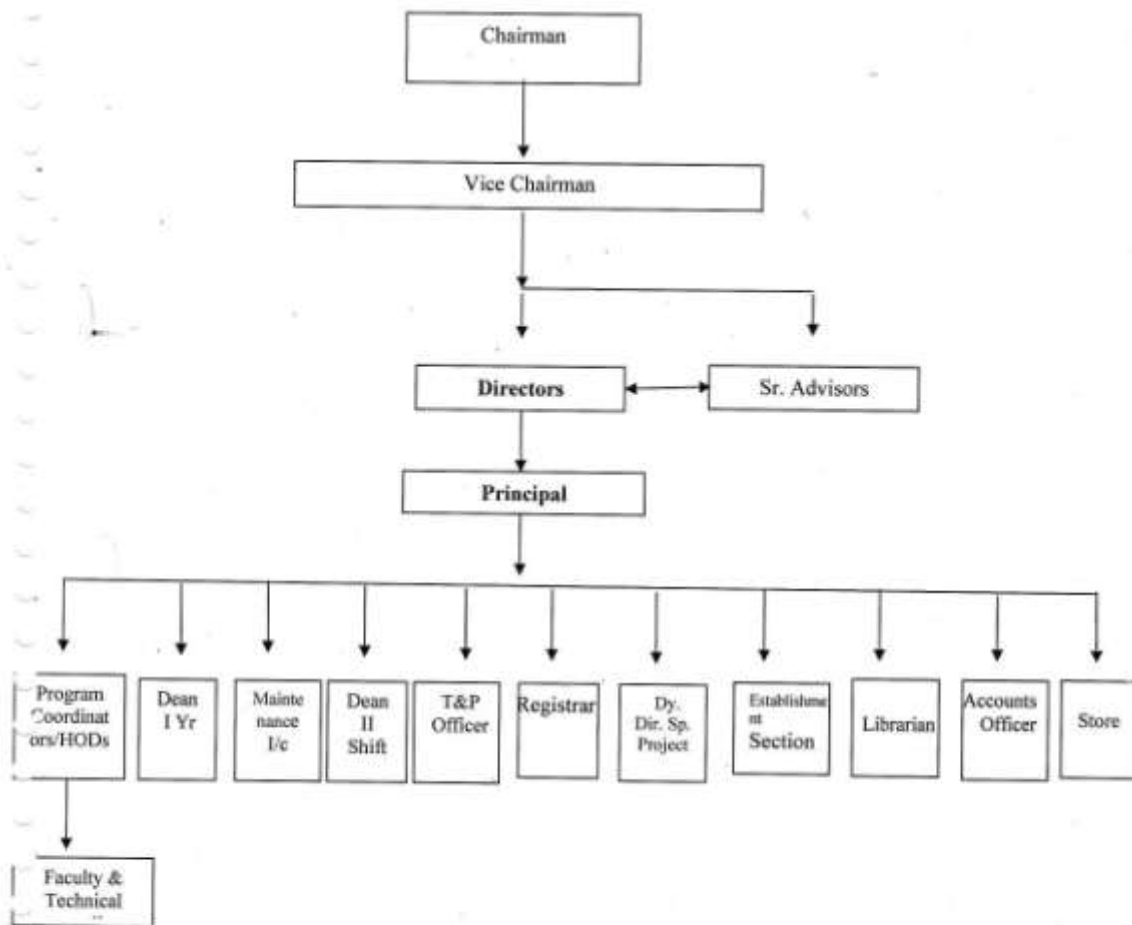

V. Par  
PRINCIPAL  
Jaipur Engineering College &  
Research Centre  
Jaipur - 303 905

# [SELF ASSESSMENT REPORT]



## Composition of grievance redressal cell including Anti-Ragging Committee & Sexual Harassment Committee

Application Status: **Submitted**  
Application Sub-Status: **Payment Received**

Report Generated on :-09/02/2018



Sr. No.	Committee Type	Appointment Order Reference No.	Date of Appointment	Name of the Committee Member	Profession	Address	Associated With	Mobile No.	E-Mail Address	Fax No.
1	OMBUDSMAN	94	25/10/2017	Not Yet Appointed	Not	Not	Not	7442 4731 05	rtu.dr.acad@gmail.com	2473 857
2	Grievance Redressal	94	25/10/2017	Ms.RAJ PAREEK	EDUCATIONIST	JECRC,SHRI RAM KI NANGAL,VIA SITAPURA RIICO,OPP EPIP GATE TONK ROAD,JAIPUR	JECRC	9982 6829 11	rajpareek@jecrc.ac.in	2770 803
3	Grievance Redressal	94	25/10/2017	Mr. Ashok Sharma	warden	JECRC,SHRI RAM KI NANGAL VIA SITAPURA,RIICO,OPP EPIP GATE TONK ROAD,JAIPUR	JECRC	9082 6829 14	ashok@jecrc.ac.in	2770 803
4	Grievance Redressal	94	25/10/2017	MS. YOGITA PUNJABI	EDUCATIONIST	228-A/3 PARVATI NAGAR RAJA PARK JAIPUR	JECRC	9887 0156 52	yogita234@gmail.com	2778 03
5	Grievance Redressal	94	25/10/2017	Dr. Vijay Singh Rathore	Educationalist	s-5, bankers colony canchyawala jaipur	JECRC	9763 3073 90	vijaydramond@gmail.com	2778 03
6	Grievance Redressal	94	25/10/2017	Sh. Anshul Mittal	EDUCATIONIST	11 CIMMCO STFF COLONY BHARATPUR RAJ 321001	JECRC	9772 8204 62	anshul.o.mittal@gmail.com	2778 03
7	Grievance Redressal	94	25/10/2017	Dr. V.K.Chandna	Principal	A-104,ASHA DEEP, GREEN AVENUE NEAR GYAN VIHAR UNIVERSITY,JAIPUR	JECRC	9891 4067 84	principal@jecrcmail.com	2770 803
8	Grievance Redressal	94	25/10/2017	Shri P K Gupta	Chief Hostel Warden	170/190, Sector-17, Pratap Nagar, Jaipur	JECRC	9982 6829 15	muktabihari.cs@jecrc.ac.in	2770 803
9	Grievance Redressal	94	25/10/2017	Dr. Rajesh Sharma	Educationalist	137, Pashim Vihar, Vaishali, Sirsi Road, Jaipur	JECRC	9024 2248 30	shekhawat48@gmail.com	2770 803
10	Grievance Redressal	94	25/10/2017	Dr. U.K.Pareek	educationalist	Near CTS Bus Stand, Vyason Ka Mohalla, Sangarner, Jaipur	JECRC	9785 5066 67	ukpareek69@yahoo.co.in	2770 803

# [SELF ASSESSMENT REPORT]



## GRIEVANCE REDRESSAL COMMITTEE FOR ACADEMIC YEAR 2016-2017

S.No.	NAME	DESIGNATION
1.	OMBUDSMAN (NOT YET)	Member
2.	Shri P.K. Tiwari	Member
3.	Shri Manish Jain	Member
4.	Shri P.K. Gupta	Member
5.	Dr. Rajesh Sharma	Member
6.	Ms. Ruchi Mathur	Member
7.	Shri Anshul Mittal	Member



## [SELF ASSESSMENT REPORT]



### GRIEVANCE REDRESSAL COMMITTEE FOR ACADEMIC YEAR 2015-2016

S.No.	NAME	DESIGNATION
1.	Shri P.K. Tiwari	Member
2.	Prof. S.N. Gupta	Member
3.	Prof. Mukht Bihari	Member
4.	Prof. S.S. Shekhawat	Member
5.	Prof. S.N. Jhanwar	Member
6.	Prof. Govind Raj	Member
7.	Ms. Neha Gupta	Member
8.	Dr. Seema Joshi	Member
9.	Prof. U.K. Pareek	Member
10.	Dr. Anita Jain	Member
11.	OMBUDSMAN (Not Yet)	Member



### GRIEVANCE REDRESSAL COMMITTEE FOR ACADEMIC YEAR 2014-2015

S.No.	NAME	DESIGNATION
1.	Shri P.K. Tiwari	Member
2.	Prof. S.N. Gupta	Member
3.	Prof. Mukht Bihari	Member
4.	Prof. S.S. Shekhawat	Member
5.	Prof. S.N. Jhanwar	Member
6.	Prof. Govind Raj	Member
7.	Ms. Neha Gupta	Member
8.	Dr. Seema Joshi	Member
9.	Prof. U.K. Pareek	Member
10.	Dr. Anita Jain	Member
11.	OMBUDSMAN (Not Yet)	Member

# [SELF ASSESSMENT REPORT]



2017-2018

N W R I - 3 S 1 3 J 1 1 0 2 7 1 7 - 0 1 0 1 0 2 8

## Application Report - Part 1

Application Status: Submitted  
Application Sub-Status: Payment Received

Report Generated on : 09/02/2018



Sr. No	Legal System Software	Legal Application Software	Internet Bandwidth in Mbps	Internet Contention Ratio	PC/Laptop exclusively available to students	PC/Laptop available in Administrative Office	No. of PC/Laptop available in Library	No. of PC/Laptop in language lab	PC/Laptop available to Faculty Members	Printers available to student
1	0	28	105	1:1	700	14	12	56	80	55

### Hostel Facility

Sr No.	No. of rooms having Single bed/room & Area of room in sq.m.	Building No.	Name of Building	No. of rooms having Double/Two bed/room & Area of room in sq.m.	Building No.	Name of Building	No. of rooms having Triple/Three bed/room & Area of room in sq.m.	Building No.	Name of Building	No. of rooms having Four bed/room & Area	Building No.	Name of Building
1	Boys 0 & 0	0	0	70 & 10.72	BH-1	BH-1	72 & 27.32	BH-2	BH-2	Boys 0 & 0	0	0
2	Girls 3 & 9.5	GH-1	Girls Hostel	3 & 13.7	GH-1	Girls Hostel	36 & 21	0	Girls Hostel	Girls 21 & 32	GIRLS HOSTEL	GH-1

### Operational Funds

Bank Name	Account No.	Bank Statement Date	Cash Balance
IOB C Bank Ltd.	50200006658008	30/01/2015	22353221

### Financial Details (in Rs)

Funds/ Grants from Central Government	0	Funds/ Grants from UGC	0
Funds/ Grants from Student Fees	404675675	Funds/ Grants from Donations	0
Funds/ Grants from State Government	0	Funds/ Grants from Other Bodies	0
Funds/ Grants raised from Other Sources/ Internal Revenue	3995683	Salary to the Teaching Staff	91265845
Remuneration to Visiting/Guest Faculty	0	Salary to Non-teaching Staff	45070840
Library (Investments)	105608	Equipment (Investments)	516424
Building Maintenance Expenses	5087369	Other Expenditure (if any)	197585407

### Company/Industry Details

Are you a Company/Industry wishing to set up a new Institute?	No
Type of Company/Industry:	NA
Company/Industry PAN No.:	NA
Company/Industry Registered Address:	NA
Is the company having Minimum 100 Cr Turnover for the last 3 years? (Attach supporting documents):	NA
Company/Industry TAN No.:	NA
Company/Industry Year of Registration:	NA

### Umbudsman/Grievance Details

Grievance Committee Appointment	Yes	OMBUDSMAN Appointment	Yes
---------------------------------	-----	-----------------------	-----

Date of Signature: 09/02/2018

Printed By : ae927181



  
 Name & Signature of Director/Principal  
 Jaipur Institute of Engineering & Technology  
 Page 23 of 28  
 Tonk Road, Jaipur - 303 905



# [SELF ASSESSMENT REPORT]



N W R I - 3 5 1 3 1 1 1 0 2 7 1 7 - 0 1 0 1 0 2 9

**Application Report - Part 1**

Application Status: **Submitted**  
 Application Sub-Status: **Payment Received**

Report Generated on :-09/02/2018



Sl. No.	Committee Type	Appointment Order Reference No.	Date of Appointment	Name of the Committee Member	Profession	Address	Associated With	Mobile No.	E-Mail Address	Fax No.
1	OMBUDSMAN	94	25/10/2017	Not Yet Appointed	Not	Not	Not	7442 4731 05	rtu.dir.acad@gmail.com	2473 857
2	Grievance Redressal	94	25/10/2017	Ms.RAJ PAREEK	EDUCATIONIST	JECRC,SHRI RAM KI NANGAL, VIA SITAPURA RIICO,OPP EPIP GATE TONK ROAD,JAIPUR	JECRC	9982 6829 11	rajpareek@jecrc.ac.in	2770 803
3	Grievance Redressal	94	25/10/2017	Mr. Ashok Sharma	warden	JECRC,SHRI RAM KI NANGAL, VIA SITAPURA,RIICO,OPP EPIP GATE TONK ROAD,JAIPUR	JECRC	9982 6829 14	ashok@jecrc.ac.in	2770 803
4	Grievance Redressal	94	25/10/2017	MS. YOGITA PUNJABI	EDUCATIONIST	228-A/3 PARVATI NAGAR RAJA PARK JAIPUR	JECRC	9987 0156 52	yogita234@gmail.com	2778 03
5	Grievance Redressal	94	25/10/2017	Dr. Vijay Singh Rathore	Educationalist	s-5, bankers colony canchyawala jaipur	JECRC	9783 3073 90	vjaydiarmond@gmail.com	2778 03
6	Grievance Redressal	94	25/10/2017	Sh. Anshul Mittal	EDUCATIONIST	11 CIMMCO STIFF COLONY BHARATPUR RAJ 321001	JECRC	9772 6204 62	anshul.o.mittal@gmail.com	2778 03
7	Grievance Redressal	94	25/10/2017	Dr. V.K.Chandna	Principal	A-104,ASHA DEEP,GREEN AVENUE NEAR GYAN VIHAR UNIVERSITY,JAIPUR	JECRC	9891 4067 84	principal@jecrcmail.com	2770 803
8	Grievance Redressal	94	25/10/2017	Shri P K Gupta	Chief Hostel Warden	170/190, Sector-17, Pratap Nagar, Jaipur	JECRC	9982 6829 15	muktabharia@jecrc.ac.in	2770 803
9	Grievance Redressal	94	25/10/2017	Dr. Rajesh Sharma	Educationalist	137, Pashim Vihar, Vaishali, Strai Road, Jaipur	JECRC	9024 2248 30	shekhawat48@gmail.com	2770 803
10	Grievance Redressal	94	25/10/2017	Dr. U.K.Pareek	educationalist	Near CTS Bus Stand, Vyason Ka Mohalla, Sanganeer, Jaipur (Raj)-2732271	JECRC	9785 5066 67	ukpareek99@yahoo.co.in	2770 803

**Anti-Ragging Related Details Provided by the Institute**

1	Constitution of Anti-Ragging Committee	Yes
2	Constitution of Anti-Ragging Squad	Yes
3	Undertaking obtained from all Students	Yes
4	Appointment of Co-coordinators	Yes

Date of Signature: 09/02/2018

Printed By : as27181



Name & Signature of Director  
**Jaipur Engineering College & Research Centre**  
 Tonk Road, Jaipur - 303 803

# [SELF ASSESSMENT REPORT]



N | W | K | I | - | 3 | 5 | 1 | 3 | 1 | 1 | 1 | 0 | 2 | 7 | 1 | 7 | - | 0 | 1 | 0 | 1 | 0 | 3 | 0

## Application Report - Part 1

Application Status: **Submitted**  
 Application Sub-Status: **Payment Received**

Report Generated on :- 09/02/2018



6	Undertaking obtained from parents of all the students	Yes
6	Undertaking obtained from students staying in Hostel	Yes
7	Undertaking obtained from parents of students staying in Hostel	Yes

### Anti-Ragging Committee/Squad Details

Sr. No.	Committee Type	Appointment Order reference No.	Date of Appointment	Name of the Committee Member	Profession	Address	Associated With	Mobile No.	E-Mail Address	Fax No.
1	Anti-Ragging Squad	95	25/10/2017	Dr. VINAY KUMAR CHANDNA	EDUCATIONIST	A/04, ASHA DEEP, GREEN AVENUE, NEAR GYAN VIHAR UNIVERSITY, JAGATPURA, JAIPUR	JECRC	96914 06784	principal@jecrcmail.com	
2	Anti-Ragging Committee	95	25/10/2017	Dr.U.K.Pareek	EDUCATIONIST	CTS Bus Stand Vyasa ka Mohalla Sanganeer Jaipur 302029	JECRC	97856 06667	tkpareek69@yahoo.co.in	
3	Anti-Ragging Committee	95	25/10/2017	Mr. Anshul Mittal	EDUCATIONIST	A-11, Cimco Staff Colony, Bharatpur (Raj)-321001	JECRC	97726 20462	ansul.o.mittal@gmail.com	
4	Anti-Ragging Committee	95	25/10/2017	Mr. Ravi Bhatnagar	Transport Incharge	193/313 Pratap Nagar Sanganeer Jaipur 302033	JECRC	90241 49459	ravibhatnagar1982@gmail.com	
5	Anti-Ragging Committee	95	25/10/2017	SH. O P JAIN	RETD. REVENUE OFFICER	JECRC CAMPUS, SHRI RAM KI NANGAL, VIA SITAPURA RIICO, TONK ROAD, JAIPUR	JECRC	94133 35550	opjain@jecrc.ac.in	
6	Anti-Ragging Committee	95	25/10/2017	MS. SHRUTI KALRA	EDUCATIONIST	53-A SCHEME-3 PRATAP NAGAR, NEAR GLASS FACTORY TONK ROAD, JAIPUR	JECRC	94143 71413	shrutikalra.eco@jecrc.ac.in	
7	Anti-Ragging Committee	95	25/10/2017	SH. P K GUPTA	CHIEF HOSTEL WARDEN	447, SHANTI NAGAR, DURGAPURA, JAIPUR	JECRC	99826 82476	ceo@jecrc.ac.in	
8	Anti-Ragging Committee	95	25/10/2017	Dr. M.P. Singh	EDUCATIONIST	467 SRI RAM VIHAR NEW MAHAL YOJANA JAGATPURA JAIPUR 302017	JECRC	94142 03639	mposhgh_76@yahoo.co.in	
9	Anti-Ragging Committee	95	25/10/2017	MS. RAJ PAREEK	HOSTEL WARDEN GIRLS	JECRC CAMPUS, SHRI RAM KI NANGAL, VIA SITAPURA RIICO, TONK ROAD, JAIPUR	JECRC	99826 82911	rajpareek@jecrc.ac.in	
10	Anti-Ragging Committee	95	25/10/2017	DR. ANITA JAIN	LIBRARIAN	D-268, SARVANAND MARG, MALVIYA	JECRC	96292 30353	anita.lib@jecrc.ac.in	

Date of Signature: 09/02/2018

Printed By : ae927181



Name & Signature of Head of Institution  
**Principal**  
 Jaipur Engineering College & Research Centre  
 Tonk Road, Jaipur - 305 905

# [SELF ASSESSMENT REPORT]



N W R I - 3 5 1 3 1 1 1 0 2 7 1 7 - 0 1 0 1 0 3 1

## Application Report - Part 1

Application Status: **Submitted**  
Application Sub-Status: **Payment Received**

Report Generated on :-09/02/2018



11	Anti-Ragging Committee	95	25/10/2017	Ms. Neelam Chaplot	EDUCATI ONST	NAGAR, JAIPUR 52 GOVERDHAN COLONY NEW SANGANER ROAD JAIPUR 302012	JECRC	94143 96960	neelam.ch aplot@gm ail.com
----	------------------------	----	------------	--------------------	--------------	--	-------	-------------	----------------------------

### Renewable Energy Related Details/Conservation of Energy Details

Sr. No.	Particulars	Details Provided by Institute
1	Total land available (in Sqm.)	51204
2	No. of buildings with roof tops	9
3	Annual electricity consumption (No. of units) during previous financial year	740619
4	Electricity Bill-Average rate per unit paid during previous financial year (Rs. / unit) & No. of units used	9
5	Renewable Energy, if any, used at present	Yes
6	Land available for placing solar photovoltaic panels (in Sqm.)	8000
7	Total approximate roof-top area available for placing solar photovoltaic panel (in Sqm.)	10770
8	Whether a policy has been adopted to use only LED lamps?	Yes
9	Remarks	LED LIGHTS ARE INSTALLED IN THE COMPLIS AT APPROPREIED PLACES

### Other Facilities

All Weather Approach (Motorized Road)	Yes	Backup Electric Supply	Yes
Barrier free Environment	Yes	CCTV Security	Yes
ERP Software	Yes	Electric Supply	Yes
General Insurance	Yes	Group Insurance	Yes
Institution Web Site	Yes	Insurance for Students	Yes
Medical & Counseling facilities	Yes	Notice Boards	Yes
Public Announcement System	Yes	Potable Water Supply	Yes
Post & Banking/ATM	Yes	Projectors in Classrooms	Yes
Sewage Disposal System	Yes	Staff Quarters	No
Telephone & FAX	Yes	Transport Facility	Yes
Vehicle Parking Facility	Yes	First Aid Facility	Yes
Rain Water Harvesting	Yes	Solar Power Systems	Yes
Appointment Of Student Counselor	Yes	Establishment Of Anti Ragging Committee	Yes
Establishment Of Committee For GC/ST	Yes	Provision to watch MOOCs Courses through Swayam	Yes
Implementation of Unnat Bharath Abhiyan:	Yes	Institution-Industry Cell:	Yes
Stand Alone Language Laboratory (Minimum 25 PCs/Laptop up to total intake of 1000.Further additional 25 PCs/Laptop per intake of 1000).	Yes		
Safety Provisions including fire and other calamities	Yes		
Establishment of Internal Complaint Committee (ICC) Committee As per section 4 of Sexual Harassment of Women at Workplace(Prevention, Prohibition and Redressal) Act, 2013	Yes		
Establishment of Grievance Redressal Committee in the Institute and Appointment of OMBUDSMAN by the University.	Yes		
Digital Payment for all Financial Transactions as per MHRD Directives	Yes		
Compliance of the National Academic Depository(NAD) as per MHRD Directives	Yes		
Display Board within the premises as well as in the Website of the Institution Indicating the Feedback Facility of Students and Faculty Available in the AICTE Web Portal	Yes		
Implementing Food Safety and Standard Act,2006 in the Institution	Yes		
Implementation of Schemes Announced by MHRD	Yes		
Offering of Skill Development Courses Approved by the Council	Yes		
Participation in the National Institutional Ranking Framework(NIRF)	Yes		
Fabrication Facility Laboratory(FABLAB) Tinkering Laboratory/Innovation Laboratory	Yes		
Waste Management and Environment Improvement Measures to Ensure a Sustainable Green Campus	Yes		
Copies of AICTE Approvals (LOA and EOA of subsequent years)obtained since Inception of Institution till date shall be placed in the Website of the Institution	Yes		
Applied for Membership of National Digital Library	Yes		
Establishment of Online Grievance Redressal Mechanism	Yes		
Whether the institution has implemented Safety and Security measures in the Campus?	Yes		
Availability of quality sanitary napkins, through sanitary napkin vending machines and ensuring safe and environment friendly disposal of used sanitary napkin through sanitary napkin incinerator	Yes		

Date of Signature: 09-02-18

Printed By : ac827181



Name & Signature of Director/Principal

Jaipur Page 25 of 28

Tonk Road, Jaipur - 302 905

# [SELF ASSESSMENT REPORT]



2016-2017

## Application Report - Part 1

Application Status: Submitted  
Application Sub-Status: Payment Received

Report Generated on : 20/02/2017

Funds/ Grants from UGC	0
Funds/ Grants from Other Bodies	0
Funds/ Grants raised from Other Sources/ Internal Revenue	7261361
Salary to the Teaching Staff	67120428
Remuneration to Visiting/Guest Faculty	81287
Salary to Non-teaching Staff:	44746952
Library (Investments)	308332
Equipment (Investments)	2084357
Building Maintenance Expenses	3828578
Other Expenditure (if any)	253130122

### Company/Industry Details

Are you a Company/Industry wishing to set up a new Institute?	No
Type of Company/Industry:	Not Applicable
Is the company having Minimum 100 Cr Turnover for the last 3 years? (Attach supporting documents):	Not Applicable
Company/Industry PAN Number:	Not Applicable
Company/Industry TAN Number:	Not Applicable
Company/Industry Registered Address:	Not Applicable
Company/Industry Year of Registration:	Not Applicable

### Funds/Grants Received Details

Data not entered by Institute

### Funds/Grants Received Details (Contd.)

Data not entered by Institute

### Ombudsman/Grievance Details

Grievance Committee Appointment	Yes
OMBUDSMAN Appointment	Yes

### Ombudsman Appointment/Grievance Committee Details

Sr. No.	Committee Type (1)	Appointment Order reference Number(2)	Date of Appointment (3)	Name of the Committee Member (4)	Profession (5)	Address (6)	Associated With(7)	Mobile Number (8)	e Mail Address (9)	Fax No. (10)
1	OMBUDSMAN	92	22/07/2015	Not Yet Appointed	Not	Not	Not	7442473105	rtu.dir.acad@gmsil.com	2473857
2	Grievance	92	10/10/2016	Dr. U.K.Pareek	educationist	Near CTS	JECRC	9785506667	ukpareek69@yahoo	2770803

Date of Signature(dd/mm/yyyy)

Seal of Institute

Name & Signature of Director/Principal

Please submit the hard copy of this Report to Regional Officer only if Application status is "Submitted" and Application Substatus is "Payment Received" / "Payment Not Applicable"

Page 38 of 44

\*\*\*Note - All the Dates in the Report are in dd/mm/yyyy format

Printed By : AICTEHELP1

# [SELF ASSESSMENT REPORT]



## Application Report - Part 1

Application Status: Submitted  
Application Sub-Status: Payment Received

Report Generated on : 20/02/2017

	Redressal			k		Bus Stand, Vyasson Ka Mohalla, Sanganer, Jaipur (Raj)-273227			oo.co.in	
3	Grievance Redressal	92	10/10/2016	Ms. PARUL TYAGI	EDUCATIONIST	54/60, Mansarovar, Near Ryan Public School, Jaipur (Raj)	JECRC	9772970343	tyagi.parul82@gmail.com	2770803
4	Grievance Redressal	92	10/10/2016	Ms. RAJ PAREEK	EDUCATIONIST	JECRC, SHRI RAM KUNANGAL, VIA SITAPURA, RIICO, OPP EPIP GATE TONK ROAD, JAIPUR	JECRC	9982682911	rajpareek@jecrc.ac.in	2770803
5	Grievance Redressal	92	10/10/2016	Mr. Ashok Sharma	warden	JECRC, SHRI RAM KUNANGAL, VIA SITAPURA, RIICO, OPP EPIP GATE TONK ROAD, JAIPUR	JECRC	9982682914	ashok@jecrc.ac.in	2770803
6	Grievance Redressal	92	10/10/2016	Dr. V.K.Chandna	Principal	A-104, ASHA DEEP, GREEN AVENUE NEAR GYAN VIHAR UNIVERSTY.	JECRC	9891406784	principal@jecrcmail.com	2770803



Date of Signature(dd/mm/yyyy)

Name & Signature of Director/Principal

Please submit the hard copy of this Report to Regional Officer only if Application status is "Submitted" and Application Substatus is "Payment Received" / "Payment Not Applicable"  
\*\*\*Note :- All the Dates in the Report are in dd/mm/yyyy format

Page 39 of 44

Printed By : AICTE/PI/12

# [SELF ASSESSMENT REPORT]



## Application Report - Part 1

Application Status: Submitted  
Application Sub-Status: Payment Received

Report Generated on : 20/02/2017

Sr.	Commi	Appointment	Date of	Name of	Professio	Address	Associated	Mobile	Fax	eMail Address	
7	Grievan ce Redres sal	92	10/10/2016	Shri Manish Jain	Educationi st	JAGAT PURA,J AIPUR 102, Anukam pa Appt., Trimurti Marg, Malviya Nagar, Jaipur	JECRC	9460124 570		sngupta @jecrc.a c.in	2770803
8	Grievan ce Redres sal	92	10/10/2016	Shri P K Gupta	Chief Hostel Warden	170/190 Sector- 17, Pratap Nagar, Jaipur	JECRC	9962682 915		muktbiha ri.cse@je crc.ac.in	2770803
9	Grievan ce Redres sal	02	10/10/2016	Dr. Rajesh Sharma	Educationi st	137, Pashim Vihar, Vaishali , Sirsi Road, Jaipur	JECRC	9024224 830		shekhaw at48@g mail.com	2770803
10	Grievan ce Redres sal	92	10/10/2016	Ms. NEELAM CHAPLOT	Educationi st	*52, Goverd han Colony, New Sangan er Road, Sodala, Jaipur (Raj)*	JECRC	9414396 960		neelam.c haplot@ gmail.co m	2770803
11	Grievan ce Redres sal	92	10/10/2016	Shri Anshul Mittal	Warden	1/1305, Malviya Nagar, Jaipur	JECRC	9829740 762		govindraj @yahoo. co.in	2770803

### Anti-Ragging Related Details Provided by the Institute

Constitution of Anti-Ragging Committee	Yes
Constitution of Anti-Ragging Squad	Yes
Undertaking obtained from all Students	Yes
Appointment of Counselors	Yes
Undertaking obtained from parents of all the students	Yes
Undertaking obtained from students staying in Hostel	Yes
Undertaking obtained from parents of students staying in Hostel	Yes

### Anti-Ragging Committee/Squad Details

Sr.	Commi	Appointment	Date of	Name of	Professio	Address	Associated	Mobile	Fax	eMail Address
Signature(dd/mm/yyyy)										

Please submit the hard copy of this Report to Regional Officer only if Application status is "Submitted" and Application Substatus is "Payment Received" / "Payment Not Applicable"

\*\*\*Note :- All the Dates in the Report are in dd/mm/yyyy format

Page 40 of 44

Printed By : AICTEHELP1



# [SELF ASSESSMENT REPORT]



## Application Report - Part 1

Application Status: Submitted  
Application Sub-Status: Payment Received

Report Generated on :-20/02/2017

No.	Item Type (1)	Order reference Number(2)	Appointment (3)	the Committee Member (4)	n (5)	(6)	With(7)	Number (8)	No (9)	(10)
1	Anti-Ragging Squad	92	10/10/2016	Dr. VINAY KUMAR CHANDNA	EDUCATIONIST	A/04, ASHA DEEP, GREEN AVENUE, NEAR GYAN VIHAR UNIVERSITY, JAGATPURA, JAIPUR	JECRC	9891406784	2770803	principal@jecrcmail.com
2	Anti-Ragging Committee	92	10/10/2016	SH. MUKT BIHARI	EDUCATIONIST	170/190 SECTOR 17, PRITAP NAGAR JAIPUR	JECRC	9982662915	2770803	muktbihari@jecrc.ac.in
3	Anti-Ragging Committee	92	10/10/2016	Mr. Anshul Mittal	EDUCATIONIST	A-11, Cimico Staff Colony, Bharatpur (Raj)-321001	JECRC	9772620462	2770803	ansul.o.mittal@gmail.com
4	Anti-Ragging Committee	92	10/10/2016	SH. O P JAIN	RETD. REVENUE OFFICER	JECRC CAMPUS, SHRI RAM KINANGAL, VIA SITAPURA, RIICO, TONK ROAD, JAIPUR	JECRC	9413335550	2770803	opjain@jecrc.ac.in
5	Anti-Ragging Committee	92	10/10/2016	MS. SHRUTI KALRA	EDUCATIONIST	53-A SCHEME-3 PRATAP NAGAR, NEAR GLASS FACTORY TONK ROAD, JAIPUR	JECRC	9414371413	2770803	shrutikalra.eco@jecrc.ac.in
6	Anti-Ragging Committee	92	10/10/2016	SH. P K GUPTA	CHIEF HOSTEL WARDEN	447, SHANTI NAGAR, DURGA PURA, JAIPUR	JECRC	9982682475	2770803	cao@jecrc.ac.in

Date of Signature(dd/mm/yyyy)



Name & Signature of Director/Principal

Please submit the hard copy of this Report to Regional Officer only if Application status is "Submitted" and Application Substatus is "Payment Received". If "Payment Not Applicable"

Page 41 of 44

\*\*\*Note :- All the Dates in the Report are in dd/mm/yyyy format

Printed By : AICTEHELP1

# [SELF ASSESSMENT REPORT]



## Application Report - Part 1

Application Status: Submitted  
Application Sub-Status: Payment Received

Report Generated on :-20/02/2017

7	Anti-Ragging Committee	92	10/10/2016	SH. MANISH JAIN	EDUCATIONIST	13/22-A, MALVIYA NAGAR, JAIPUR	JECRC	9214699647	2770803	manish_jecrc@yahoo.com
8	Anti-Ragging Committee	92	10/10/2016	MS. RAJ PAREEK	HOSTEL WARDEN GIRLS	JECRC CAMPUS, SHRI RAM KINANGAL, VIA SITAPURA RIICO, TONK ROAD, JAIPUR	JECRC	9982082911	2770803	rajpareek@jecrc.ac.in
9	Anti-Ragging Committee	92	10/10/2016	DR. ANITA JAIN	LIBRARIAN	D-268, SARVAN AND MARG, MALVIYA NAGAR, JAIPUR	JECRC	9829230353	2770803	anita.lib@jecrc.ac.in
10	Anti-Ragging Committee	92	10/10/2016	SH. R. P. JAIN	OFFICE SUPRINTENDRNT	6/418, MALVIYA NAGAR, JAIPUR	JECRC	9636079550	2770803	rpjain@jecrc.ac.in

### Renewable Energy Installation Details/Conservation of Energy

Total land available (in Sq. mts.)	51204
No. of buildings with roof tops	9
Annual electricity consumption (No. of units) during previous financial year	623237
Electricity Bill-Average rate per unit paid during previous financial year (Rs. / unit) & Number of units used	9
Renewable Energy, if any, used at present	Yes
Renewable Energy Type(solar/Wind/Tidal/etc)	Solar base water heating system is installed at roof top at the hostel. There are 9 such unit available in the premises.
Land available for placing solar photovoltaic panels (in sq. mts.)	5000
Total approximate roof-top area available for placing solar photovoltaic panel (in sq.mts.)	9577
Whether a policy has been adopted to use only LED lamps ?	Yes
Remarks	LED LIGHTS ARE INSTALLED IN THE COMPUS AT APPROPRIED PLACES.



Date of Signature(dd/mm/yyyy)

Name & Signature of Director/Principal

Please submit the hard copy of this Report to Regional Officer only if Application status is "Submitted" and Application Substatus is "Payment Received" / "Payment Not Applicable"

Page 42 of 44

\*\*\*Note :- All the Dates in the Report are in dd/mm/yyyy format

Printed By : AICTEHELP1



# [SELF ASSESSMENT REPORT]



JAIPUR ENGINEERING COLLEGE AND RESEARCH CENTRE,  
(SHRI RAM KI NANGAL, VIA SITAPURA RIICO, OPP. EPIP GATE, TONK ROAD, JAIPUR-302022)

## OFFICE ORDER

13.10.2015

### Students' & Hostellers Grievance Redressal Committee

With a view to redressing the grievances of the students and the hostellers, Committee consisting of the undernoted members is constituted:

S.NO.	NAME	POST	MOBILE NO.
1	Sh. P.K. Tiwari, (Sr. Advisor)	Chairman	9829044224
2	Prof. Dr.V.K. Chandna	Co-Chairman	9891406784
3	Prof. Dr.U.K. Pareek	Secretary	9785506667
4	Prof. Dr.Jyoti Thanvi	Member	9772781250
5	Sh. Manish Jain	Member	9214699647
6	Sh. Mukesh Agarwal	Member	9214044474
7	Sh. Sunil Jangir	Member	9251039749
8	Ms.Jisha Vargise	Member	9784468656
9	Ms. Parul Tyagi	Member	9772970343
10	Sh. R.S.Agarwal	Member	9460117479
11	Ms.Raj Pareek	Member	9982682911
12	Dr. Rajesh Sharma	Member	7877546888
13	Sh. K.B.Pareek	Member	9982682909
14	One Invited member		

The committee will meet every second and forth Wednesday from 3:15 PM To 4:00 PM to hear the complaints of students and also look into the arrangements of hostels.



PRINCIPAL

# [SELF ASSESSMENT REPORT]



JAIPUR ENGINEERING COLLEGE AND RESEARCH CENTRE,  
(SHRI RAM KI NANGAL, VIA SITAPURA RIICO, OPP.EPIP GATE, TONK ROAD, JAIPUR-302022)

2015-2016

## Anti Raging Committee

An anti raging committee to prevent raging is the JECRC Campus has been constituted, following are the members of the anti raging committee.

S.NO.	NAME	POST	MOBILE NO.
1	Sh. O.P.Jain	Chairman	9413335550
2	Sh.M.L.Sharma	Vice-Chairman	9414279663
3	Dr. V.K.Chandna	Principal	9891406784
4	Sh. P.K.Tiwari	Sr. Advisor	9772524494
5	All Programme-Co-Ordinators	All HOD's	
6	Sh.R.S.Agarwal	Registrar	9460117479
7	Sh.P.K.Gupta	Chief Administrative Officer	9982682475
8	Dr. Jyoti Thanvi	Chief Co-Ordinator(1st Year)	9772781250
9	Sh.R.P.Jain	Office Superintendent	9636079550
10	Sh.K.B.Pareek	Chief Warden	9982682909
11	Dr.Anita Jain	Chief Librarian	9829230353
13	Dr. U.K.Pareek	Member	9785506667
14	Sh.L.Senthil	Member	8952934577



(Chairman)

*M.M.*  
*8-8-18*

**OFFICE OF THE CENTRAL MONITORING COMMITTEE**  
JECRC Campus, Shri Ram Ki Nangal, Via-Sitapura, Near Sanganer Sadar Thana, Tonk Road, Jaipur-302022

*8-8-18*

**MINUTES OF THE MEETING HELD ON 26/07/2018 TO CURB THE MENACE OF RAGGING**

A) Meeting was held on 26<sup>th</sup> July 2018 in JECRC campus at 15 hours. The agenda of meeting was to curb the menace of ragging in College campus. The following were present: -

1. Shri M.L. Sharma, Vice-Chairman
2. Prof. S.N. Gupta, Senior Advisor
3. Shri R.S. Agarwal, Director ABD
4. Dr. Anurakt Williamson, Registrar
5. Dean – I Year
6. Dean – II Shift
7. Shri Anshul Mittal
8. Shri P.K. Gupta Chief Administrative Officers/Chief Warden and other Wardens
9. All Heads of the Departments
10. All Administrative Heads
11. Shri Malli Ram- Security Guard

B) **Agenda of the Meeting:** - The meeting was held specifically for the purpose of having discussion to curb the menace of ragging in our institutions and also to keep the campus ragging free as was being done in previous years

C) 1. Shri M.L. Sharma, Vice-Chairman of this committee first welcomed all the participants, thanked all the members for refrain the campus ragging free, as no case of ragging was reported to the Central Monitoring Committee. He also mentioned that today's news in News Paper that ragging cases were doubled in past all over the country.

2. In the Meeting, the discussions were made in details pertaining to features of the Regulations framed by the UGC and as directed by the Raghavan Committee constituted by the Hon'ble Supreme Court. The members discussed the following main points.

- a) Constitute of Anti Ragging & Anti Ragging squads, Monitoring Cell & Disciplinary Committee.
- b) Obtaining undertakings from Students & Parents.



**OFFICE OF THE CENTRAL MONITORING COMMITTEE**  
JECRC Campus, Shri Ram Ki Nangal, Via-Sitapura, Near Sanganer Sadar Thana, Tonk Road, Jaipur-302022

- c) Security in Campus & Busses.
  - d) Preparation and display of Posters in Campus, Mr. Anshul Mittal was asked to help in preparation of some effective display.
  - e) Duties & responsibilities of Hostel Wardens and coordinators particularly during the first quarter of the session.
  - f) Holding Meetings, Seminars, Joint sensitization programmes involving students, faculty, parents, guardians, District authorities.
  - g) Notices with telephone numbers of important persons to be used by students in case of ragging.
  - h) Identifying vulnerable places in the campus.
3. Dr. U.K. Pareek suggested that more alertness is required at recess period. Dr. Barkha Srivastava, Dr. Lokesh Bansal, Dr. Seema Joshi, Shri Atul Kulshreshtha, Shri Ashok Sharma-Warden, and Shri Malli Ram also gave suggestions to make the campus ragging free.
4. The Registrar informed the members that posters have already been displayed in the campus, committees have been formed, UGC's guidelines & Supreme Courts directions have been included in the prospectus & vulnerable places have been identified.
5. The Registrar also expressed his views to take precautions before misshaping with new-comers and stressed on the point that every staff member whether he/she included in Anti Ragging squad or not should take appropriate action if he/she finds any kind of harassment with junior students. Efforts should be made that not even a single case of ragging occurs in any circumstances. Vice Chairman Shri M.L. Sharma added that there should be in this context some extent of the balanced view approach should be adopted.
- a) In hostels, the deputed faculties must render their duties especially in night shift sincerely and counsel both first year and senior class students.

**OFFICE OF THE CENTRAL MONITORING COMMITTEE**  
JECRC Campus, Shri Ram Ki Nangal, Via-Sitapura, Near Sanganer Sadar Thana, Tonk Road, Jaipur-302022

- b) At main gate, the security guard must maintain incoming and outgoing students register for new admitted students who avails hostel facility specially in the evening time.
6. All the discussions made in the meeting were taken as approved.
7. In the end Shri M.L.Sharma, Vice-Chairman, Anti-Ragging Committee thanked all the members for their active participation. In concluding remarks he stated that we have to be more vigilant particularly for the vulnerable positions, so identified, including Hostels and cafeteria. He further observed that for involvement of a student in ragging, we may punish him, but more important thing was to prevent such incidents.

  
**Prof. (Dr.) A. Williamson**  
**Registrar**  
Jaipur Engineering College and Research Centre



Copy to: -

1. Shri M.L. Sharma, Vice-Chairman
2. Shri Amit Agrawal, CMD,
3. Shri Arpit Agrawal, Director
4. Shri P.K. Tewari, Senior Advisor
5. Dr. V.K. Chandna, Principal
5. Registrar, JECRC, Jaipur
6. Shri P.K. Gupta, Chief Administrative Officer/Chief Warden

# [SELF ASSESSMENT REPORT]



## JECRC

Notice No-  
Date - 27/07/2018

### ANTI RAGGING ORGANISATION

Sh. O.P. Jain Chairman  
Sh. P.K. Tiwari Chief Mentor  
Prof. U. K. Pareek Chief Proctor

#### A. Anti-ragging committee -

The team of staff members specified for a particular zone shall take regular rounds of zone and shall maintain complete vigilance for the prevention of ragging in the areas under their control. They will maintain regular report of their observations. Ragging incidents if any, shall be reported immediately to the under mentioned for further action at their following mobile numbers-

Prof. U.K. Pareek Chief Proctor 9785506667  
Sh. P.K. Gupta C.A.O 9982682475  
Prof. M. P. Singh Proctor 9414203639

S. No.	Name	Phone No.	Zone	Control Area
1	<b>Sh. Gajendra Sharma (In-charge)</b> Sh. Amit Mithal Sh. Pradeep Sharma Sh. Vikas Sharma Sh. Veni Madhav Sharma Mr. Teekam Singh		A	Police station to college main gate  Reporting time 8.00 AM
2	<b>Ms. Neelam Choudhary (In-charge)</b> Sh. Prahlad Sharma Ms. Geetika Gautam Sh. Ashish Ameria Sh. Arihant Jain		B	Main gate to cycle stand and porch
3	<b>Dr. Manish Srivastava (In-charge)</b> Sh. Kuldeep Sharma Sh. Rajendra Gupta Sh. Lalit Sharma Sh. Narendra Singh		C	Canteen, Cafè Block & D Block
4	<b>Sh. Ashok Sharma (In-charge)</b> Ms. Sanjay Devi Dr. Rajesh Sharma Ms. Yogita Panjabi		D	Hostel to Block-A
5	<b>Sh. S.S. Manaktala (In-charge)</b> Sh. Ram Singh Dr. Rajesh Sharma Sh. Honey Agarwal Sh. Sandeep K. Dotliya Sh. Ashish K. Kulshrestha		E	Hostels to B Block and Hostels to C Block
6	<b>Dr. Bhuvnesh Bhardwaj (In-charge)</b> Dr. Manish Srivastava Sh. Anil Jain Sh. Devendra Sharma Sh. Hemant Vashisth		F	Electrical & Electronics and Block B
7	<b>Ms. Manju Vyas (In-charge)</b> Ms. Shikha Maheshwari Ms. Richa Sharma Ms. Sarita Sh. Tovindra Kumar Sahu Sh. Sachin Gupta		G	Block -A

## [SELF ASSESSMENT REPORT]



8	<b>Dr. Rajesh Bhatija (In-charge)</b> Sh. Ravi Kumar Jangir Sh. Aashish Nagpal Sh. Mangi Lal Ms. Ritu Vyas Sh. Hanuman Pd.		H	Playground & field, Canteen and around
9	<b>Ms. Sheela Soni (In-charge)</b> Ms. Neha Singh Ms. Sonali Chadha Ms. Parul Tyagi		I	Area near Girls Hostel
10	<b>Dr. Anita Jain (Incharge)</b> All other library staff		J	Library – 1
11	<b>Mr. Kamlesh Choudhary (In-charge)</b> Ms. Monika Sharma Mr. Amit Mittal Mr. Jitesh Kumar Jain All Library-3 staff (block C)		K	Block C - Basement Floor
12	<b>Dr. Rekha Mithal (In-charge)</b> Ms. Barkha Srivastava Ms. Sarita Poonia # Sh. Dilip Parjapta Sh. Jitendra Gupta		L	Block C – Ground Floor
13	<b>Dr. Seema Joshi (In-charge)</b> Dr. R.K. Mangal Dr. S. K. Dixit Dr. Tripti Gupta Dr. Poonam Gupta		M	Block C – First Floor
14	<b>Sh. Shiv Shankar Sharma (In-charge)</b> Dr. S. K. Singh Mr. Vishal Sagtani Ms. Rekha Vijay Sh. Piyush Gautam Dr. Sunil Srivastava		N	Block C – Second Floor
15	<b>Sh. Sunil Jangir (In-charge)</b> Ms. Kusum Yadav Mr. Naveen Kumar Kedia Sh. Manoj Pathak		O	Block C – Third Floor
16.	<b>Jitendra Sharma (In-charge)</b> Raj Kumar Jain Ashish Sharma Devesh Gupta	-	-	Near Shiv Temple, Tea Stall, outside the JECRC main gate.
17.	<b>Yogesh Dubey (In-charge)</b> Shrikant Bansal Abhay Bhatt Man Mohan	-	-	Block D

**Notwithstanding the above, it is expected from all teaching faculty and other staff members that if they come across any incident of harassment of the new comers they shall intervene immediately and try to prevent RAGGING. The matter may also be brought to the notice of the above.**



# [SELF ASSESSMENT REPORT]



## Notes:-

1. Every faculty member should ensure proper handing over of the class to the next faculty member. He/ She should not leave the class without a proper supervision and presence of faculty member.
2. The nearest HOD of the area should ensure one of the faculty members of the area is always present in verandas to maintain discipline.
3. All institute staff should invariably wear their I-cards.

The wardens of the hostels should ensure that all 1st semester students leave the hostels everyday by 8.25 AM positively and preferably in one group.

Anonymous random surveys have been planned in different zones. The proctors, mentors and others will also be meeting each section of 1st year classes at least once in a fortnight.

## Anti-ragging Committee Session 2018-19

S.No	Name	Designation	Mobile No.
1.	Dr. U.K Pareek	Chief Protcter	09785506667
2.	Ms. Bhawana Sharma	Proctor	09214465405
3.	Mr. Anshul Mittal	Proctor	09772620462
4.	Ms. Shruti Kalra	Proctor	09414371413
5.	Dr. M.P Singh	Proctor	09414203639
6.	Dr. Anita Jain	Chief Librarian	09829230353
7.	Ms. Roopsi Singh	Warden Girls Hostel	08601436125
8.	Mr. Ravi Bhatnagar	Transport In charge	09024149459
9.	Sh. PK Gupta	Chief Warden/C.A.O	09982682475

**Dr. A. Williamson, Registrar 08209270915**

  
Principal

## Copy to –

1. Vice Chairman, Director, All concerned
2. All HOD, Librarian A & C Block.
3. CAO/Chief Warden with a request to get the above notice circulated among all the staff members working under their control.





# [SELF ASSESSMENT REPORT]



Message

ice Suptd. JECRC <os@jecrc.ac.in> Sat, Aug 18, 2018 at 3:49  
hodcse <hod.cse@jecrc.ac.in>, HoD IT <hod.it@jecrc.ac.in>, hodme <hod.me@jecrc.ac.in>, Hodee  
od.ee@jecrc.ac.in>, hodce <hod.ce@jecrc.ac.in>, hodchem <hod.chem@jecrc.ac.in>, hodmaths  
d.maths@jecrc.ac.in>, hodeh <hod.eh@jecrc.ac.in>, hodphy <hod.phy@jecrc.ac.in>, hodece <hod.ece@jecrc.ac.i  
"p.k. Gupta" <cao@jecrc.ac.in>, Registrar JECRC <registrar@jecrc.ac.in>, Principal JECRC  
ncipal@jecrcmail.com>, Librarian JECRC <librarian@jecrc.ac.in>, "U.K. Pareek" <ukpareek.math@jecrc.ac.in>

Dear Sir/Madam,

Hostel night duty from 21.08.2018 to 10.09.2018 is being enclosed for information and needful.

Regards  
Mitabh Gupta

## JAIPUR ENGINEERING COLLEGE & RESEARCH CENTRE

**Circular No. 11**  
18.08.2018



### CIRCULAR

Following faculty members will also perform the night duty from **8 PM to 9 AM** as per the date mentioned below. They will visit the hostel mess during this period and will take meal in their respective hostel. They will report to Chief Hostel Warden -

Date	Day	Girl's Hostel	Boy's Hostel
21.08.2018	Tuesday	Ms. Shikha Maheshwari, CSE	Mr. Anoop Kumar Mehta, CSE Mr. Hetram Sharma, Civil
22.08.2018	Wednesday	Ms. Nida Khanam, Civil	Mr. Bhoopesh Kumawat, ECE Mr. Manish Pal, EE
23.08.2018	Thursday	Ms. Sonali Chadha, EE	Mr. Satyendra Kumar, ME Mr. Brijesh Kumar Singh, IT
24.08.2018	Friday	Ms. Ruchida Barman, E&H	Mr. Akhil Maheshwari, Civil Mr. Sachin Gupta, CSE
25.08.2018	Saturday	Ms. Deepika Bansal, IT	Mr. Shailendra Srivastava, EE Mr. Jitendra Kumar Sharma, ECE
26.08.2018	Sunday	Dr. Rekha Mithal, Chemistry	Mr. Ravi Yadav, ME Mr. Narendra Sipani, Civil
27.08.2018	Monday	Ms. Palak Jindal, ME	Mr. Pradeep Sharma, CSE Mr. Nikhil Jain, ME

mail.google.com/mail/u/0/?ui=2&ik=33998498f2&isver=TKereZPTSMY.en.&cbl=gmail\_fe\_180822.12\_p2&view=pt&q=night%20duty&q=tru...

# [SELF ASSESSMENT REPORT]



9/1/2018

JECRC Mail - Hostel night duty

28.08.2018	Tuesday	Ms. Geetika Gautam, CSE	Mr. Vikas Mishra, ECE Mr. Sunil Kumar Sharma, EE
29.08.2018	Wednesday	Dr. Vinita Mathur, ECE	Mr. Taj Bahadur Singh, ME Mr. Shashi Kant Singh, CSE
30.08.2018	Thursday	Dr. Sarita Poonia, Maths	Mr. Satya Prakash Saini, ME Mr. Prateek Kumar Sharma, Civil
31.08.2018	Friday	Ms. Yogita, ECE	Mr. Shailesh Arrawatia, CSE Mr. Ashish Boiradia, Civil
01.09.2018	Saturday	Ms. Richa Upadhyay, CSE	Mr. Pravin Kumar Sharma, CSE Dr. Sunil Kumar Srivastava, Maths
02.09.2018	Sunday	Ms. Rekha Vijay, Chemistry	Mr. Jitendra Gupta, ME Dr. Sanjay Gaur, CSE
03.09.2018	Monday	Ms. Shikha Srivastava, IT	Mr. Anil Jain, ECE Dr. Vishal Saxena, Maths
04.09.2018	Tuesday	Ms. Anima Sharma, CSE	Mr. Man Mohan Siddh, ME Mr. Sandeep Kumar Dotya, ECE
05.09.2018	Wednesday	Dr. Seema Joshi, Chemistry	Mr. Gajendra Sharma, CSE Mr. Tejendra Singh, ME
06.09.2018	Thursday	Ms. Parul Tyagi, ECE	Mr. Dayal Singh Rathore, ME Mr. Ashish Sharma, ECE
07.09.2018	Friday	Ms. Shweta Sharda, ECE	Dr. Mukul Kumar Sharma, E&H Mr. Nitin Chhabra, ME
08.09.2018	Saturday	Ms. Archana Vijayvergia, E&H	Mr. Shrikant Bansal, ME Mr. Honey Agarwal, ECE
09.09.2018	Sunday	Dr. Tripati Gupta, Maths	Mr. Ravi Kuamr Jangir, ME Mr. Veni Madhav Sharma, ECE
10.09.2018	Monday	Ms. Swati Vijay, IT	Mr. Yogesh Kumar Agarwal, Civil Mr. Devesh kumar, ME

All are required to submit their **report** in writing along with **Annexure A** to the Chief Hostel Warden next day. The CCL for the same shall be granted on the written recommendation of the CAO.

Principal

#### Copy to-

1. Vice -Chairman
2. Director
3. Chief Hostel Warden
4. All Programme Coordinator/HoD's - with a request to get the duty noted from all

# [SELF ASSESSMENT REPORT]



## ROLES & RESPONSIBILITIES CHART FOR NIGHT DUTY IN HOSTEL

<u>S. NO.</u>	<u>FROM</u>	<u>TO</u>	<u>LOCATION OF DUTY</u>	<u>REPORTING TO</u>	<u>SIGNATURE OF WARDEN</u>
<u>1.</u>	8 PM	9 PM	Presence in the Mess	Warden	-
<u>2.</u>	9 PM	10 PM	Presence in the Lawn by the Male faculty member & Quadrangles by the Female faculty member	Warden	-
<u>3.</u>	10 PM	11 PM	Hostel rooms visit	Warden	-
<u>4.</u>	11 PM	11.30 PM	Tea time		-
<u>5.</u>	11.30 PM	12.30 PM	Hostel rooms visit.	Warden	-
<u>6.</u>	12.30 AM		Rest	-	-
<u>7.</u>	3 AM	4 AM	Round of hostel and ground.	Warden	-
<u>8.</u>	8 AM	9 AM	Tea & Breakfast	-	-

Date: -

Signature of Faculty member



# [SELF ASSESSMENT REPORT]



## JAIPUR ENGINEERING COLLEGE AND RESEARCH CENTRE REPORT ON NIGHT DUTY

Dear Sir

Our night duty was scheduled on 3 August 2018 (Friday) to avoid ragging in (if any) Boys Hostel-I and Boys Hostel-II. We arrived at JECRC campus at 8 PM and reported to hostel warden Mr. Ashok Sharma. We stayed there overnight and visited both boys hostels BH-1 and BH-2 and nothing found suspicious. Also we talked to first year students, they don't have any issue till moment. They are enjoying their new phase of life. We instructed them to call/inform immediately to their respective hostel warden in case if they find anything uncomfortable.

**Annexure -A**

### ROLES & RESPONSIBILITIES CHART FOR NIGHT DUTY IN HOSTEL

S. NO.	FROM	TO	LOCATION OF DUTY	REPORTING TO	SIGNATURE OF WARDEN
1.	8 PM	9 PM	Presence in the Mess	Warden	
2.	9 PM	10 PM	Presence in the Lawn by the Male faculty member & Quadrangles by the Female faculty member	Warden	
3.	10 PM	11 PM	Hostel rooms visit	Warden	
4.	11 PM	11.30 PM	Tea time	-	-
5.	11.30 PM	12.30 PM	Hostel rooms visit.	Warden	
6.	12.30 AM		Rest	-	-
7.	3 AM	4 AM	Round of hostel and ground.	Warden	
8.	8 AM	9 AM	Tea & Breakfast	-	-

Date: - **3/8/18**

Signature of Faculty member

1. Lalit Kumar Sharma

2. Piyush Gautam

# [SELF ASSESSMENT REPORT]



JECRC Mail - Fwd: Vigilance Duty of Faculty members in CSE Department

Anurakt Williamson Registrar <registrar@jecrc.ac.in>

## Fwd: Vigilance Duty of Faculty members in CSE Department

1 message

Principal JECRC <principal@jecrc.ac.in>  
To: Registrar JECRC <registrar@jecrc.ac.in>

Wed, Aug 8, 2018 at 2:37 PM

----- Forwarded message -----

From: HoD CS <hod.cse@jecrc.ac.in>  
Date: Wed, Aug 8, 2018 at 12:50 PM  
Subject: Vigilance Duty of Faculty members in CSE Department  
To: Geet Kalaniq <geetkalani.cse@jecrc.ac.in>, Amit Mithal <amitmithal.cse@jecrc.ac.in>, Pradeep Sharma <pradeepsharma.it@jecrc.ac.in>, "Dr.Sanjay Gaur" <sanjaygaur.cse@jecrc.ac.in>, Ashish Ameria <ashishameria.cse@jecrc.ac.in>, Gajendra Sharma <gajendrasharma.cse@jecrc.ac.in>  
Cc: Manju Vyas <manjuvyas.cse@jecrc.ac.in>, Principal JECRC <principal@jecrc.ac.in>

Dear All,

Following faculty members are assigned vigilance duty around main gate and around the local shop areas. They must take round every day and ensure that no students are found sitting there.

- 1) Mr. Geet Kalani Between 12::00-1:00 pm
- 2) Mr. Amit Mithal Between 12::00-1:00 pm
- 3) Mr. Pradeep Sharma Between 3:00-500 pm
- 4) Dr. Sanjay Gaur Between 3:00-500 pm
- 5) Mr. Ashish ameria Between 10- 11AM
- 6) Mr Gajendra Sharma Between 9-10 AM

Any act of indiscipline found must be reported immediately.

Thanks and regards

**Dr. Bhavna Sharma**

Head, Department of Computer Science & Engineering  
Jaipur Engineering College & Research Centre  
Address: JECRC Campus, via Sitapura, Tonk Road, Jaipur-302022, Rajasthan, India

Warm Regards

Dr. Vinay Kumar Chandna,  
B.E., M.E. Ph.D. (Electrical)  
SM IEEE, LM ISTE, LMCSI  
Principal,  
Jaipur Engineering College and Research Centre (Jaipur),  
Tonk Road, Jaipur  
Past Treasurer PES Delhi Chapter,  
Chair IEEE Education Society,  
98914 06784 (M)



# [SELF ASSESSMENT REPORT]



## JECRC

Notice No-

Date – 31.07.2017

### ANTI RAGGING ORGANISATION

Sh. O.P. Jain  
Sh. P.K. Tiwari  
Prof. U. K. Pareek

Chairman  
Chief Mentor  
Chief Proctor

#### A. Anti-ragging committee –

The team of staff members specified for a particular zone shall meet and devise an action plan to take regular rounds of zones and shall maintain complete vigilance for the prevention of ragging in the areas under their control. They will maintain regular report of their observations. Ragging incidents if any, shall be reported immediately to the under mentioned for further action at their following mobile numbers-

Prof. U.K. Pareek	Chief Proctor	9785506667
Sh. P.K. Gupta	C.A.O	9982682475
Prof. M. P. Singh	Proctor	9414203639

S.No.	Name	Zone	Control Area
1	Sh. Mukesh Agarwal Sh. Amit Mithal Sh. Gajendra Sharma Sh. Udbhav Bhatnagar Sh. Pradeep Sharma Sh. Vikas Sharma	A	Police station to college main gate  Reporting time 8.00 AM
2	Ms. Neelam Chaplot Sh. Prahlad Sharma Ms. Geetika Gautam Sh. Ashish Ameria Sh. Arihant Jain	B	Main gate to cycle stand and porch
3	Dr. Manish Srivastava Sh. Kuldeep Sharma Sh. Rajendra Gupta Sh. Lalit Sharma Sh. Narendra Singh	C	Canteen and Workshops (D and E Block)
4	Sh. P.K. Gupta Sh. Ashok Sharma Ms. Raj Pareek Dr. Rajesh Sharma	D	Hostel to Block-A

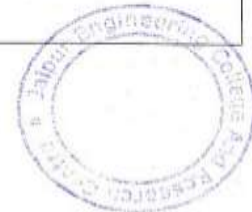

## [SELF ASSESSMENT REPORT]



5	<b>Sh. S.S. Manaktala- Proctor</b> <b>Sh. Ram Singh</b> <b>Ms. Poonam Gupta</b> <b>Dr. Rajesh Sharma</b> Sh. Honey Agarwal Sh. Sandeep K. Dotiya Sh. Ashish K. Kulshrestha	E	Hostels to B Block and Hostels to C Block
6	<b>Sh. Shruti Kalra-Proctor</b> <b>Dr. Bhuvnesh Bhardwaj</b> <b>Dr. Manish Srivastava</b> Ms. Shikha Gaur Sh. Anil Jain Sh. Devendra Sharma Sh. Veni Madhav Sharma Sh. Hemant Vashisth Sh. Vishwas Verma	F	Electrical, Electronics and Mechanical .....
7	<b>Sh. R.S. Agarwal, Mentor</b> <del>Sh. R.P. Jain</del> <b>Dr. Anita Jain</b> Ms. Shikha Maheshwari Ms. Manju Vyas Ms. Richa Sharma Ms. Sarita Sh. Tovindra Kr. Sahu Sh. Aizaj Khan Sh. Sachin Gupta	G	Block -A
8	<b>Dr. Rajesh Sharma</b> <b>Dr. S.K. Dixit, Mentor</b> Sh. Ravi Kumar Jangir Sh. Aashish Nagpal Sh. Mangi Lal Ms. Ritu Vyas Sh. Hanuman Pd.	H	Play ground & field, Canteen and around
9	<b>Ms. Raj Pareek, Mentor</b> <b>Ms. Sheela Soni</b> <del>Ms. Suman Devi</del> Ms. Neha Singh Ms. Sonali Chadha Ms. Vinita Mathur Ms. Parul Tyagi	I	Area near Girls Hostel
10	<b>Dr. Anita Jain</b> All other library staff	J	Library – 1
11	<b>Mr. Kamlesh Choudhary</b> <b>Ms. Monika Sharma</b> <b>Mr. Amit Mittal</b> Mr. Jitesh Kumar Jain Mr. Rohit Singhal All Library-3 staff (block C)	K	Block C - Level – 1
12	<b>Dr. Rekha Mithal</b> <b>Prof. K.K. Agarwal</b> Ms. Barkha Srivastava Ms. Sarita Poonia Sh. Dilip Parjapta	L	Block C - Level – 2



## [SELF ASSESSMENT REPORT]



	Sh. Jitendra Gupta		
13	<b>Dr. Seema Joshi- Proctor</b> <b>Dr. R.K. Mangal</b> <b>Dr. S. K. Dixit</b> <b>Dr. Tripti Gupta</b> <b>Dr. Poonam Gupta</b> <b>Ms. Yogita Panjabi</b>	M	Block C - Level – 3
14	<b>Sh. Shiv Shankar Sharma</b> <b>Sh. Manoj Pathak</b> Dr. S. K. Singh Mr. Vishal Sagtani Ms. Rekha Vijay Sh. Piyush Gautam Dr. Sunil Srivastava	N	Block C - Level – 4
15	<b>Sh. Sunil Jangir</b> Ms. Kusum Yadav Mr. Naveen Kumar Kedia <del>Ms. Pallavi Singh</del>	O	Block C - Level-5
16	<b>Sh. P.K. Gupta</b> <b>Sh. Manish Jain</b> <b>Sh. R.S. Agarwal &amp; staff</b> <b>Sh. R.P. Jain &amp; staff</b> <b>Dr. Umesh K. Pareek</b> Sh. Ashok Patni Sh. Ramesh Rawat	P	College & other areas, General assistance to the Principal
17.	<b>Rajesh Kumar Bathija</b> Raj Kumar Jain Ashish Sharma Devesh Gupta	-	Near Shiv Temple, Tea Stall, outside the JECRC main gate.
18.	<b>Atul Kulshrestha</b> Ashok Singh Chundawat Rahul Kumar Malee Shailendra Srivastava	-	Block D

\* Names in bold letters are the incharges of their respective zones.





## [SELF ASSESSMENT REPORT]



**Notwithstanding the above, it is expected from all teaching faculty and other staff members that if they come across any incident of harassment of the new comers they shall intervene immediately and try to prevent RAGGING. The matter may also be brought to the notice of the above.**

Notes:-

1. Every faculty member should ensure proper handing over of the class to the next faculty member. He/She should not leave the class without a proper supervision and presence of faculty member.
2. The nearest HOD of the area should ensure one of the faculty members of the area is always present in varandas to maintain discipline.
3. All institute staff should invariably wear their I-cards.

The wardens of the hostels should ensure that all the I semester students leave the hostels everyday by 8.25 AM positively and preferably in one group.

Anonymous random surveys have been planned where proctors and mentors and also other subject experts will be meeting each section of the I year classes atleast once in a fortnight. The random survey will be carried out in any of the randomly selected regular classes, so that the students are not aware of the forthcoming surveys.

### **B. Anti-ragging Committee Session 2017-18**

S.No	Name	Designation	Mobile No.
1.	Dr. U.K Pareek	Chief Protcter	09785506667
2.	Ms. Neelam Chaplot	Proctor	09414396960
3.	Mr. Anshul Mittal	Proctor	09772620462
4.	Ms. Shruti Kalra	Proctor	09414371413
5.	Dr. M.P Singh	Proctor	09414203639
6.	Dr. Anita Jain	Chief Librarian	09829230353
7.	Ms. Raj Pareek	Warden Girls Hostel	09982682911
8.	Mr. Ravi Bhatnagar	Transport Incharge	09024149459
9.	Sh. PK Gupta	Chief Warden/C.A.O	09982682475

Sh. R.S. Agarwal, Registrar 09460117479

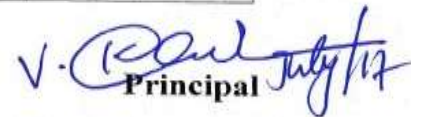
  
Principal

Copy to –

1. Vice Chairman, Director, All concerned
2. All HoD, Librarian A & C Block.
3. CAO/Chief Warden with a request to get the above notice circulated among all the staff members working under their control.



**Jaipur Engineering College and Research Centre**

**Anti Ragging Committee Session 2016-17**

S.No	Name	Designation	Mobile No.
1.	Prof. Mukht Bihari	Chief Proctor	09982682915
2.	Aizaz Khan	Assistant Registrar	09982682906
3.	Dr. U.K Pareek	Dean 1 <sup>st</sup> Year	09785506667
4.	S.S Manaktala	Proctor	09828089494
5.	Shiv Shankar Sharma	Proctor	09929860331
6.	Sh. Manish Jain	Proctor	09214699647
7.	Dr. Seema Joshi	Proctor	09251039861
8.	Ms. Shruti Kalra	Proctor	09414371413
9.	Dr. Anita Jain	Chief Librarian	09829230353
10.	Ms. Raj Pareek	Warden Girls Hostel	09982682911
11.	Sh. R.P. Jain	Office Supdt. & Transport Incharge	09636079550
12.	Sh. PK Gupta	Chief Warden	09982682475

Please contact above members with regarding to above mentioned subject.

  
**Registrar**

**Note: All Notice Board including Hostel Notice Board.**



## [SELF ASSESSMENT REPORT]



### ANTI-RAGGING COMMITTEES FOR THE ACADEMIC YEAR 2016-2017

S.No.	Name of Member	Designation	Contact No.
1.	Prof. Mukht Bihari	Member	9982682915
2.	Shri O.P. Jain	Member	9413335550
3.	Ms. Shruti Kalra	Member	9414371413
4.	Shri P.K. Gupta	Member	9982682475
5.	Shri Manish Jain	Member	9214699647
6.	Ms. Raj Pareek	Member	9828118064
7.	Ms. Anita Jain	Member	9829230353
8.	Shri R.P. Jain	Member	9636079550



# [SELF ASSESSMENT REPORT]



## JECRC

Notice No. 11/.....

Date..28.10.16

### ANTI RAGGING ORGANISATION

Sh. O.P. Jain  
Sh. P.K. Tiwari  
Prof. Mukht Bihari

Chairman  
Chief Mentor  
Chief Proctor

#### A. Anti-ragging committee –

The team of staff members specified for a particular zone shall meet and devise an action plan to take regular rounds of zones and shall maintain complete vigilance for the prevention of ragging in the areas under their control. They will maintain regular report of their observations. Ragging incidents if any, shall be reported immediately to the under mentioned for further action at their following mobile numbers-

Prof. Mukht Bihari	Chief Proctor	9982682915
Sh. P.K. Gupta	C.A.O	9982682475
Prof. U.K. Pareek	Proctor	9785506667

S.No.	Name	Zone	Control Area
1	Sh. Manish Jain – Proctor Sh. Mukesh Agarwal Sh. Amit Mithal Sh. Gajendra Sharma Sh. Udbhav Bhatnagar Sh. Pradeep Sharma Sh. Vikas Sharma	A	Police station to college main gate  Reporting time 8.00 AM
2	Ms. Neelam Chaplot Sh. Prahlad Sharma Ms. Geetika Gautam Sh. Anshul Mittal Sh. Arianth Jain	B	Main gate to cycle stand and porch
3	Prof. Gobind Raj Sh. Kuldeep Sharma Sh. Rajendra Gupta Sh. Lalit Sharma Sh. Narendra Singh	C	Canteen and Workshops (D and E Block)
4	Sh. P.K. Gupta Sh. Ashok Sharma Ms. Raj Pareek Dr. Rajesh Sharma	D	Hostel to Block-A



## [SELF ASSESSMENT REPORT]



5	<b>Sh. S.S. Manaktala- Proctor</b> <b>Sh. Ram Singh</b> <b>Ms. Poonam Gupta</b> <b>Dr. Rajesh Sharma</b> Sh. Honey Agarwal Sh. Sandeep K. Dotiya Sh. Ashish K. Kulshrestha	E	Hostels to B Block and Hostels to C Block
6	<b>Sh. Shruti Kalra-Proctor</b> <b>Prof. R. Gobind Raj</b> <b>Prof. R.O. Rustagi</b> Ms. Shikha Gaur Sh. Anil Jain Sh. Devendra Sharma Sh. Veni Madhav Sharma Sh. Hemant Vashisth Sh. Vishwas Verma	F	Electrical, Electronics and Mechanical .....
7	<b>Sh. R.S. Agarwal, Mentor</b> <b>Sh. R.P. Jain</b> <b>Dr. Anita Jain</b> Ms. Shikha Maheshwari Ms. Manju Vyas Ms. Richa Sharma Ms. Anima Sharma Sh. Tovindra Kr. Sahu Sh. Aizaj Khan Sh. Sachin Gupta Sh. ABL Mathur	G	Block -A
8	<b>Dr. Rajesh Sharma</b> <b>Dr. S.K. Dixit, Mentor</b> Sh. Ravi Kumar Jangir Sh. Aashish Nagpal Sh. Mangi Lal Ms. Ritu Vyas Sh. Hanuman Pd.	H	Play ground & field, Canteen and around
9	<b>Ms. Raj Pareek, Mentor</b> <b>Ms. Sheela Soni</b> Ms. Suman Devi Ms. Neha Singh Ms. Sonali Chadha Ms. Vinita Mathur Ms. Parul Tyagi	I	Area near Girls Hostel
10	<b>Dr. Anita Jain</b> All other library staff	J	Library – 1
11	<b>Ms. Anjana Poonia</b> <b>Prof. S.K. Sur</b> <b>Prof. S.K. Saxena</b> Sh. Kartik Chawala Sh. Sumit Saini All Library-3 staff (block C)	K	Block C - Level – 1
12	<b>Dr. Reelha Mithal</b> <b>Prof. M.L. Rawat</b> <b>Prof. K.K. Agarwal</b> Ms. Barkha Srivastava	L	Block C - Level – 2



## [SELF ASSESSMENT REPORT]



	Ms. Sarita Poonia Sh. Rajendra Sen Sh. Dilip Parjapta Sh. Jitendra Gupta Sh. Mount Malik		
13	<b>Dr. Seema Joshi- Proctor</b> <b>Dr. R.K. Mangal</b> <b>Dr. Urmila Gupta</b> <b>Ms. Priyanka Verma</b> <b>Dr. Poonam Hariyani</b> <b>Sh. Shivani Agrawal</b>	M	Block C - Level – 3
14	<b>Sh. Shiv Shankar Sharma</b> <b>Sh. Manoj Pathak</b> Dr. Ankush Dr. Savita Sangwan Ms. Rekha Vijay Sh. Piyush Gautam Sh. Kanishk Jain Sh. Neha Jain	N	Block C - Level – 4
15	<b>Sh. Sunil Jaagir</b> Ms. Kusum Yadav Sh. Swati Vijay Ms. Neha Jain	O	Block C - Level-5
16	<b>Sh. P.K. Gupta</b> <b>Sh. Manish Jain</b> <b>Sh. R.S. Agarwal &amp; staff</b> <b>Sh. R.P. Jain &amp; staff</b> Dr. Umesh K. Pareek Sh. Ashok Patni Sh. Ramesh Rawat	P	College & other areas, General assistance to the Principal
17.	<b>Rajesh Kumar Bathiya</b> Raj Kumar Jain Ashish Sharma Devesh Gupta	-	Near Shiv Temple, outside the JECRC main gate.
18.	<b>Atul Kulshrestha</b> Ashok Singh Chundawat Rahul Kumar Malee Shailendra Srivastava	-	Block D

\* Names in bold letters are the incharges of their respective zones.



**ction to be taken to curb ragging during the session 2015-16**

Inbox x

2:31 PM (37 minutes ago)

**Principal JECRC**

to vc, Arpit, opjain, pktiware, cao, hod.cse, hodece, HoD, Hodee, hodme, hodge, suchintyasur.ce, ranjcetpandey., jyotithanvi.ma., hodmaths, hodeh, hodchem, hodphy, ruchimathur.ma., rekhamithal.ch., Saritapoonia.m., rajendrasen.ch., me, librarian, jyotithanvi\_28

Jaipur Engineering College & Research Centre

From : Principal Office

To : All Programme Coordinators

Noting Reference No. JECRC/01/2015-16/09

22/07/2015

Sub.: Action to be taken to curb ragging during the session 2015-16

As you are aware that II,III and IV year classes are already started and the I year classes are commencing from August 6, 2015. Therefore you along with your colleagues are requested to make it convenient to attend the meeting in the auditorium on Wednesday the 29<sup>th</sup> of July, 2015 at 3:15 PM. You are also requested to come prepare with the following agenda items –

**ACTION TO BE TAKEN TO CURB RAGGING SESSION 2015-2016**

1. Notice explaining as to what constitutes ragging are to be put up on the Notice Board.
2. Notice for prohibition & prevention of ragging is to be displayed.
3. Declarations from student & parents are to be obtained.
4. Meetings with Hostel Wardens, student representatives, parents/guardian, faculty & district administration are to be held.
5. Multi color posters of big size for promotion of law and nature of punishment for involvement in ragging is to be displayed at conspicuous places.
6. Vulnerable position in the campus are to be identified.

## [SELF ASSESSMENT REPORT]



7. Induction programme is to be planned.
8. Printed leaflet to be handed over to the students containing contact Nos of persons to be informed in case of ragging takes place and also informing about the calendar of events, including induction.
9. List of contact nos to be displayed inside each bus.
10. Joint sensitization programme of freshers and seniors to be planned and organized.
11. Letters to the parents of first year completing students are to be sent informing about the law regarding ragging and punishments.
12. Monitoring cell is to be formed.
13. Individual meeting with the freshers for psychological counseling is to be planned/held.
14. Anonymous random survey across 1st year batch freshers every fortnightly is to be planned for the first 3 months of the session.
15. Meeting with faculty and non-teaching staff to be held to apprise them of about their responsibility towards curbing the menace of ragging.
16. Anti ragging committee and Anti ragging squad, to be formed and information about their constitution to be given to the Central Monitoring Committee.
17. An appropriate committee to monitor, promote and regulate healthy interaction between freshers and senior students, to be formed institution wise.
18. Posters informing that the burden of proof shall be on the preparator of ragging and not on the victim to be displayed.
19. Posters acknowledging non-involvement of seniors in the past to be displayed.
20. Seminar/Meeting with district authorities to promote the feeling of ragging free campus to be planned and held.
21. Admission brochure to contain the directions of Hon'ble Supreme Court and the UGC.
22. Hostel Wardens to obtain declarations from the students and their parents duly signed & verified.
23. Websites of the institutions to contain the directions of the Supreme Court and UGC regarding ragging.
24. Tight security in the campus to be planned and executed.
25. Advertisement for admission to clearly mention that ragging is totally banned in the Institution.
26. The school leaving certificate/TC/MC and character certificate shall contain, report about the behavioural pattern of the students.
27. Hostel wardens to have mobile phones to be accessible at all hours.
28. For the initial period of 3 months, from the date of start of the college, hostellers should not be allowed to move out from the hostel between 8.30 pm to 5.00 am.
29. Disciplinary committees to be formed.
30. Audio-visual aids, counseling session, workshops, Painting, design competitions may be organized.
31. Services of Shri P.K. Tiwari, Senior Advisor and retired Director General Police should be utilized to make the students understand the repercussions of their involvement in



## [SELF ASSESSMENT REPORT]



ragging. For this purpose, class wise programmes may be chalked out in consultation with Shri P.K. Tiwari, Senior Advisor, and thereafter, action may be taken accordingly.

32. Each & Every HOD to hold meetings with their Department and impress upon the faculty and staff that, curbing the menace of ragging, was the duty of each Individual being a member of the Institute.



Copy to –

1. Vice Chairman
2. Director
3. Sr. Advisors
4. All Programme Coordinators
5. Chief Hostel Warden, CAO, Librarian
6. Registrar, OS – As discussed, submit the report on Monday i.e. on July 27, 2015

# [SELF ASSESSMENT REPORT]



## JAIPUR ENGINEERING COLLEGE AND RESEARCH CENTRE

Dear Students,

1. We welcome and congratulate you for seeking admission in this college. It is a fact that in this transitional phase you have left your school life and probably homely environment and would be entering into a new phase. Therefore, we would be more than willing to help you solving problems/difficulties, if any faced by you as a fresher and would extend all the necessary help.
2. To overcome the menace of ragging, college, administration has already made plans for FRESHERS' inducations and orientation, which promote efficient and effective means of integrating. These planse will be communicated to you by the office shortly.
3. Besides, we all would ensure that ugly scar of ragging is obliterated from the face of all educational institutions. Here, we would like to inform you that you may turn up to the following persons in case of any help/guidance in the most unlikely event of the so-called ragging.

S.No.	Name	Designation	Mobile Number
1.	Dr. UK Pareek	Chief Proctor	9785506667
2.	Ms. Ruchi Mathur	Proctor	9828159024
3.	Mr. Anshul Mittal	Proctor	9772620462
4.	Ms. Shruti Kalra	Proctor	9414371413
5.	Dr. M. P. Singh	Proctor	9414203639
6.	Dr. Anita Jain	Chief Librarian	9829230353
7.	Ms. Sanjay Raghav	Warden Girls Hostel	9982603534
8.	Mr. Ravi Bhatnagar	Transport Incharge	9024149459
9.	Sh. PK Gupta	Chief Warden/CAO	9982682475
10.	Sh. Ashok Sharma	Warden Boys Hostel	9982682914

4. You are instructed that you should desist form doing anything against your will even if required by the seniors and should not have any fear, as the institution cares for you and shall not tolerate any mischief against any student.
5. You are requested not to hesitate in seeking any help and guidance and to report any incidents of harassment, teasing etc., either as victim or even as a witness.

May I add that your college has always been ragging-free.

Wishing you a bright future in the college.



V. Singh  
July 2011  
Principal

WOMEN CELL

2015-2016

JAIPUR ENGINEERING COLLEGE AND RESEARCH CENTRE,  
(SHRI RAM KI NANGAL, VIA SITAPURA RIICO, OPP.EPIP GATE, TONK ROAD, JAIPUR-302022)

**Women Cell**

In accordance with the directives from AICTE New Delhi and RTU Kota, the existing Women cell for safe and secure working environments for girls and Women at JECRC Campus is hereby re-constituted as follows with immediate effect.

S.NO.	NAME	POST	MOBILE NO.
1	Dr. Seema Joshi	Chairperson	9413689436
2	Dr. Anita Jain	Secretary	9829230353
3	Ms.Neelam Chaplot	Member	9414396960
4	Dr.Urmila Gupta	Member	9772524494
5	Dr.Umesh Pareek	Member	9785506667
6	Smt. Raj Pareek	Member	9982682911
7	Ms. Ritu Vyas	Member	9462213444

The Chairperson is requested to convene frequent meetings with Women staff and girl students and communicate any complaints and action taken thereon to the Vice-Chairman, the Director, The Principal and also the Registrar for onward transmission to the RTU, if necessary.

The Chairperson may also communicate the essence of any meetings held with the Government agencies, NGOs etc.

  
Principal

**10.1.4. Delegation of financial powers**

NATIONAL SOCIETY FOR ENGINEERING RESEARCH AND DEVELOPMENT, JAIPUR.  
10-10-2015

**Delegation of powers to the various authorities**

The Chairman, JECRC Foundation, and the National Society for Engineering Research and Development, has directed me to convey the delegation of powers to the various authorities working in the NSERD promoted institutions. Our Esteemed Chairman is of the view that the College Principal and the Registrar should have adequate powers so that they are in a position to comply with the requirements of the regulatory and supervising bodies, and conduct day-to-day affairs in a positive and peaceful manner, under their own authority and signatures.

With a view to ensuring smooth and unambiguous functioning of the colleges, viz., Jaipur Engineering College And Research Centre, as also JECRC UDML College of Engineering, the delegated powers / authority are detailed hereunder:

Designated Authority	Powers delegated
a) Principal	i) As Head of the Institution, he shall exercise his authority for institution building. He will act as Competent Authority for all Faculty Members and Officer staff and be responsible for overall human resource management, their appointment, utilization, retrenchment, termination, disciplinary action, etc. He will exercise signing powers as Competent Authority. ii) He will act as superintendent and guide for all items of work related to AICTE, RTU (Affiliating University), UGC, MHRD, Technical Education Department GOR, State Level Fees Determination Committee, and other regulatory or higher bodies. iii) Establish a climate in which faculty members and the students can develop self-discipline, and promote research. iv) To formulate the Budget and assess the infrastructural and other requirements well in advance and get the same approved from the Secretary, NSERD before execution. v) Impress amount of Rs. 1,00,000/- (Rs. One Lakh Only) is also delegated for routine exercise.
b) Registrar	a) He shall act Competent Authority for all office and sub-staff, and exercise signing powers as competent authority for their appointment, utilization, retrenchment, termination, disciplinary action, etc. b) He shall act as <b>Compliance Officer</b> to fulfill the regulatory guidelines etc. of AICTE, RTU (Affiliating University), UGC, MHRD, Technical Education Department GOR, State Level Fees Determination Committee, and other regulatory or higher bodies. He shall act as

**Chairman:** Overall Incharge of the College

**Principal:** responsible for faculty development and research activities; smooth functioning of the Institute.

**Program Coordinators / HODs:** Are responsible for administration and academic activities of their program / departments.

**Dean I Year:** is responsible for administration and academic activities related to I year.

**Dean II Shift:** is responsible for administration and academic activities related to II shift.

**Maintenance Incharge:** is responsible for maintenance related issues in the campus.

**T & P Officer:** is responsible for Training and placement related activities in the Campus.

**Registrar:** Deals with admissions, registration and results of students and all other issues related to students and the Rajasthan Technical University.

**Accounts:** All issues related to student fees, budget and payment.

**Establishment:** Deals with all issues related to staff recruitment, increments, promotions, provident fund, gratuity and salary bills etc.

**Financial Power Delegation to the Program Coordinators/HODs –** impress amount of Rs. 10,000/- is sanctioned to the all Program Coordinators/HODs and on submission of account further amount is disbursed.

**10.1.5. Transparency and availability of correct/unambiguous information in public Domain**

All Information's are available at College Website, Students Broachers, Liberty etc.





# [SELF ASSESSMENT REPORT]

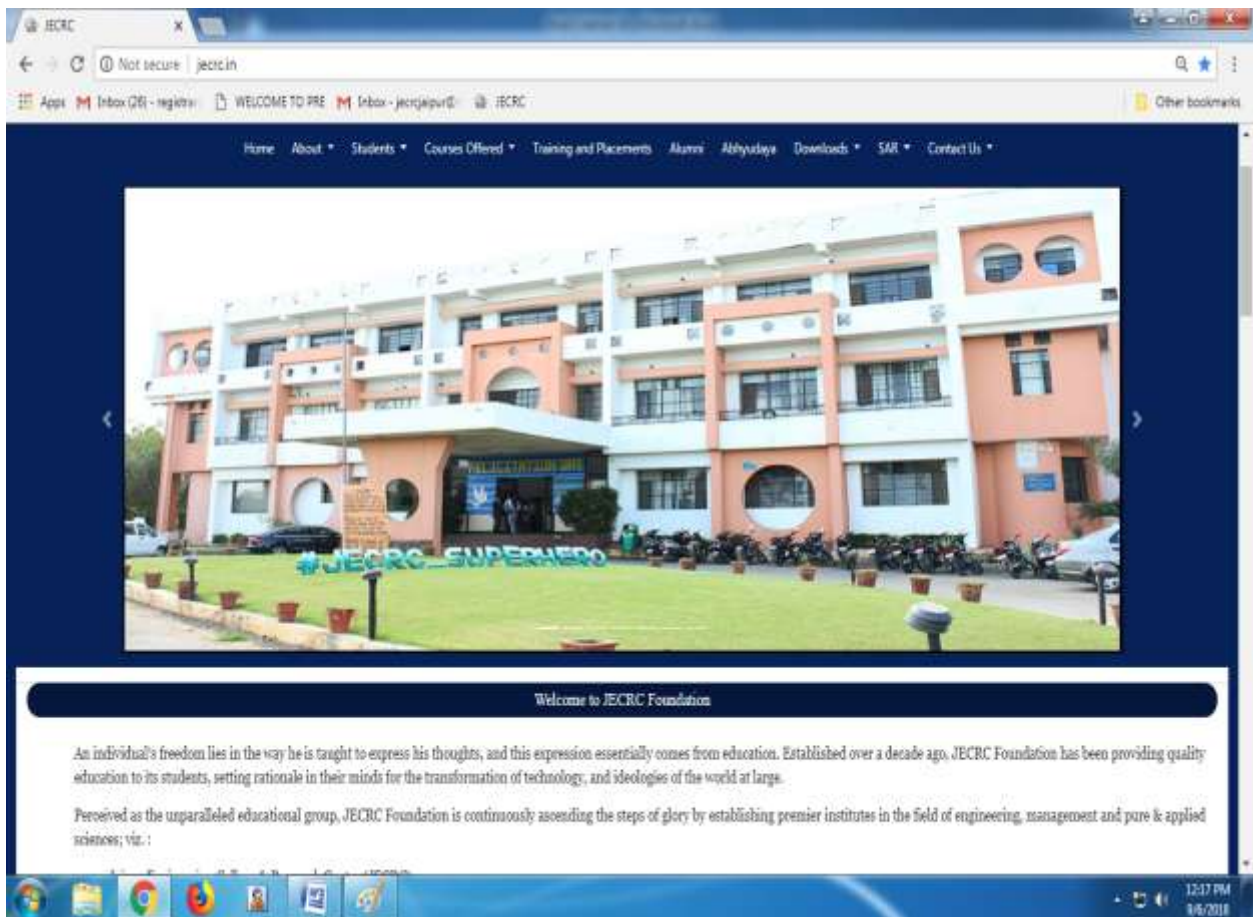

The screenshot shows the JECRC website homepage. At the top, there is a navigation menu with links for Home, About, Students, Courses Offered, Training and Placements, Alumni, Aahyudya, Downloads, SAR, and Contact Us. Below the menu is a large banner image of the JECRC building, a multi-story structure with a central entrance and a sign that reads "JECRC SUPERHERO". Below the banner, there is a "Welcome to JECRC Foundation" section with a paragraph of text: "An individual's freedom lies in the way he is taught to express his thoughts, and this expression essentially comes from education. Established over a decade ago, JECRC Foundation has been providing quality education to its students, setting rationale in their minds for the transformation of technology, and ideologies of the world at large. Perceived as the unparalleled educational group, JECRC Foundation is continuously ascending the steps of glory by establishing premier institutes in the field of engineering, management and pure & applied sciences; etc."

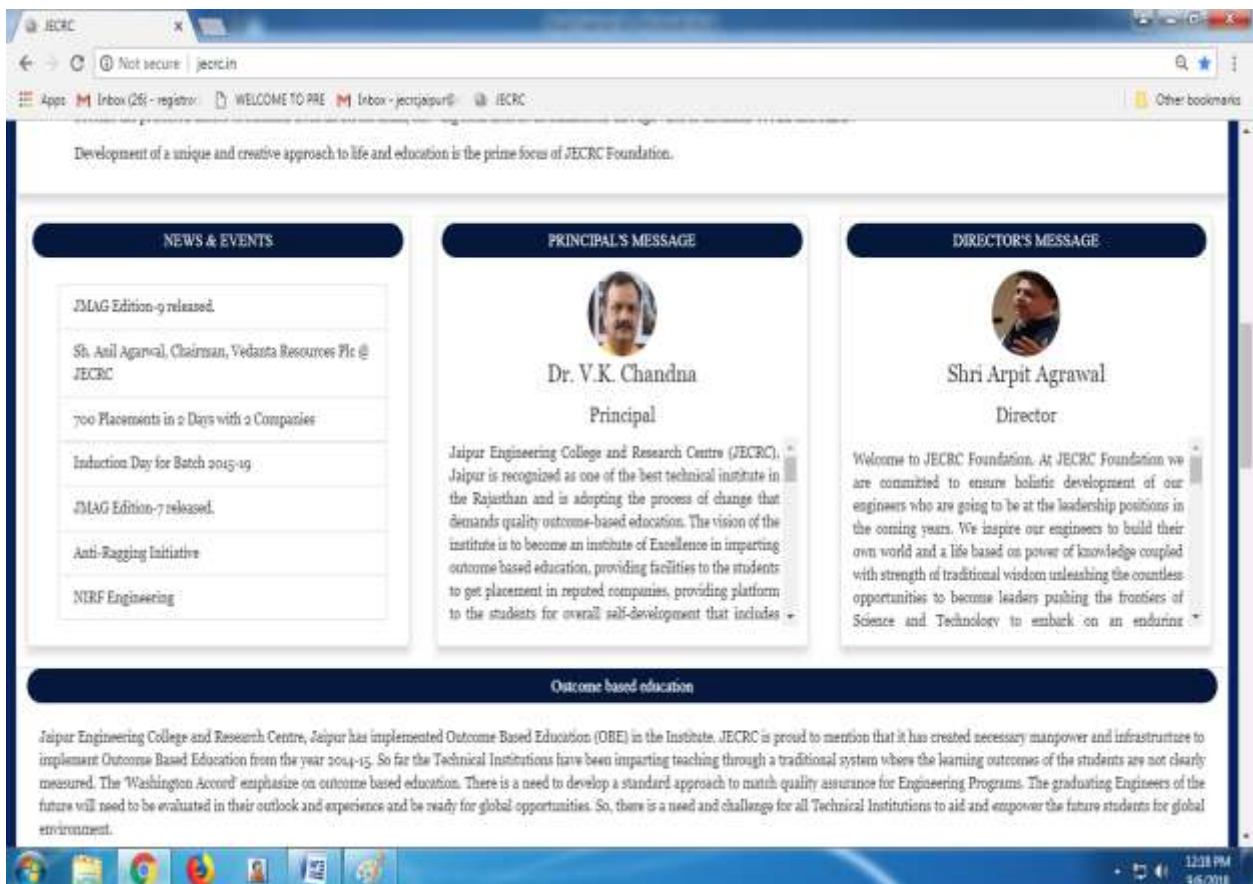

The screenshot shows the "NEWS & EVENTS" and "PRINCIPAL'S MESSAGE" sections of the JECRC website. The "NEWS & EVENTS" section lists several items: "JMAG Edition-9 released", "Sh. Anil Agarwal, Chairman, Vedanta Resources Plc @ JECRC", "700 Placements in 2 Days with 2 Companies", "Induction Day for Batch 2015-19", "JMAG Edition-7 released", "Anti-Ragging Initiative", and "NERF Engineering". The "PRINCIPAL'S MESSAGE" section features a portrait of Dr. V.K. Chandna, Principal, and a paragraph of text: "Jaipur Engineering College and Research Centre (JECRC), Jaipur is recognized as one of the best technical institute in the Rajasthan and is adopting the process of change that demands quality outcome-based education. The vision of the institute is to become an institute of Excellence in imparting outcome based education, providing facilities to the students to get placement in reputed companies, providing platform to the students for overall self-development that includes...". The "DIRECTOR'S MESSAGE" section features a portrait of Shri Arpit Agrawal, Director, and a paragraph of text: "Welcome to JECRC Foundation. At JECRC Foundation we are committed to ensure holistic development of our engineers who are going to be at the leadership positions in the coming years. We inspire our engineers to build their own world and a life based on power of knowledge coupled with strength of traditional wisdom unleashing the countless opportunities to become leaders pushing the frontiers of Science and Technology to embark on an enduring...". Below these sections is a "Outcome based education" section with a paragraph of text: "Jaipur Engineering College and Research Centre, Jaipur has implemented Outcome Based Education (OBE) in the Institute. JECRC is proud to mention that it has created necessary manpower and infrastructure to implement Outcome Based Education from the year 2014-15. So far the Technical Institutions have been imparting teaching through a traditional system where the learning outcomes of the students are not clearly measured. The 'Washington Accord' emphasize on outcome based education. There is a need to develop a standard approach to match quality assurance for Engineering Programs. The graduating Engineers of the future will need to be evaluated in their outlook and experience and be ready for global opportunities. So, there is a need and challenge for all Technical Institutions to aid and empower the future students for global environment."



# [SELF ASSESSMENT REPORT]



Browser: JECRC | Not secure | jecrc.in

**Welcome to JECRC Foundation**

An individual's freedom lies in the way he is taught to express his thoughts, and this expression essentially comes from education. Established over a decade ago, JECRC Foundation has been providing quality education to its students, setting rationale in their minds for the transformation of technology, and ideologies of the world at large.

Perceived as the unparalleled educational group, JECRC Foundation is continuously ascending the steps of glory by establishing premier institutes in the field of engineering, management and pure & applied sciences; viz.:

- Jaipur Engineering College & Research Centre (JECRC)
- JECRC University

Every year, more than 5000 students entrust JECRC Foundation with the responsibility of shaping their minds for a better future. Commanding the priority list of best engineering colleges in Jaipur, it has become the preferred choice of students from all across India, showing keen interest in admissions through various mediums of JEE and REAP.

Development of a unique and creative approach to life and education is the prime focus of JECRC Foundation

12:28 PM 1/6/2018

Browser: JECRC | Not secure | jecrc.in

The faculty and technical staff members are committed to enter professional as well as research driven project based opportunities to become leaders pushing the frontiers of Science and Technology to embark on an enduring

**Outcome based education**

Jaipur Engineering College and Research Centre, Jaipur has implemented Outcome Based Education (OBE) in the Institute. JECRC is proud to mention that it has created necessary manpower and infrastructure to implement Outcome Based Education from the year 2014-15. So far the Technical Institutions have been imparting teaching through a traditional system where the learning outcomes of the students are not clearly measured. The 'Washington Accord' emphasize on outcome based education. There is a need to develop a standard approach to match quality assurance for Engineering Programs. The graduating Engineers of the future will need to be evaluated in their outlook and experience and be ready for global opportunities. So, there is a need and challenge for all Technical Institutions to aid and empower the future students for global environment.

The Outcome Based Education focuses on outcomes through achievement of learning objectives of their program. The OBE strongly emphasize student centric learning and adaptation of modern teaching-learning systems. JECRC has gone far ahead in implementing OBE where every student will distinctly write-down the learning outcomes in every hour of lecture he/she attends. The Teachers have been given specialized training to embark on OBE method of delivery and use of modern teaching-learning systems. With this OBE, it is expected that the students distinctly gain excellent knowledge in their relevant branch and contribute to the development of the organizations where they are employed.

JECRC is also a Centre for imparting training on NBA which emphasize on OBE. The OBE process at JECRC is expected to raise the standards of Technical Education imparted in the Institute in the coming years. JECRC is committed for creating knowledge, skills and problem solving abilities among students of all ranks.

12:28 PM 1/6/2018

# [SELF ASSESSMENT REPORT]



JECRC

Not secure | jecrc.in

Apps | Inbox (26) - registrar | WELCOME TO PRE | Inbox - jectajapur | JECRC

The Outcome Based Education focuses on outcomes through statement of learning objectives in their program. The OBE strategy emphasizes student result, retaining and acquisition of concepts, teaching-learning systems. JECRC has gone far ahead in implementing OBE where every student will distinctly write-down the learning outcomes in every hour of lecture he/she attends. The Teachers have been given specialised training to embark on OBE method of delivery and use of modern teaching-learning systems. With this OBE, it is expected that the students distinctly gain excellent knowledge in their relevant branch and contribute to the development of the organizations where they are employed.

JECRC is also a Centre for imparting training on NBA which emphasize on OBE. The OBE process at JECRC is expected to raise the standards of Technical Education imparted in the institute in the coming years. JECRC is committed for creating knowledge, skills and problem solving abilities among students of all ranks.

Photo Gallery



OUR PRIDE



12:25 PM  
3/4/2018

JECRC

Not secure | jecrc.in

Apps | Inbox (26) - registrar | WELCOME TO PRE | Inbox - jectajapur | JECRC

JECRC is also a Centre for imparting training on NBA which emphasize on OBE. The OBE process at JECRC is expected to raise the standards of Technical Education imparted in the institute in the coming years. JECRC is committed for creating knowledge, skills and problem solving abilities among students of all ranks.

Photo Gallery



OUR PRIDE



12:25 PM  
3/4/2018

# [SELF ASSESSMENT REPORT]



The Outcome Based Education focuses on outcomes through achievement of learning objectives of their program. The OBE strongly emphasize student centric learning and adaptation of modern teaching-learning systems. JECRC has gone far ahead in implementing OBE where every student will distinctly write-down the learning outcomes in every hour of lecture he/she attends. The Teachers have been given specialized training to embark on OBE method of delivery and use of modern teaching-learning systems. With this OBE, it is expected that the students distinctly gain excellent knowledge in their relevant branch and contribute to the development of the organizations where they are employed.

JECRC is also a Centre for imparting training on NDA which emphasize on OBE. The OBE process at JECRC is expected to raise the standards of Technical Education imparted in the Institute in the coming years. JECRC is committed for creating knowledge, skills and problem solving abilities among students of all ranks.

Photo Gallery

## OUR PRIDE

## OUR PRIDE





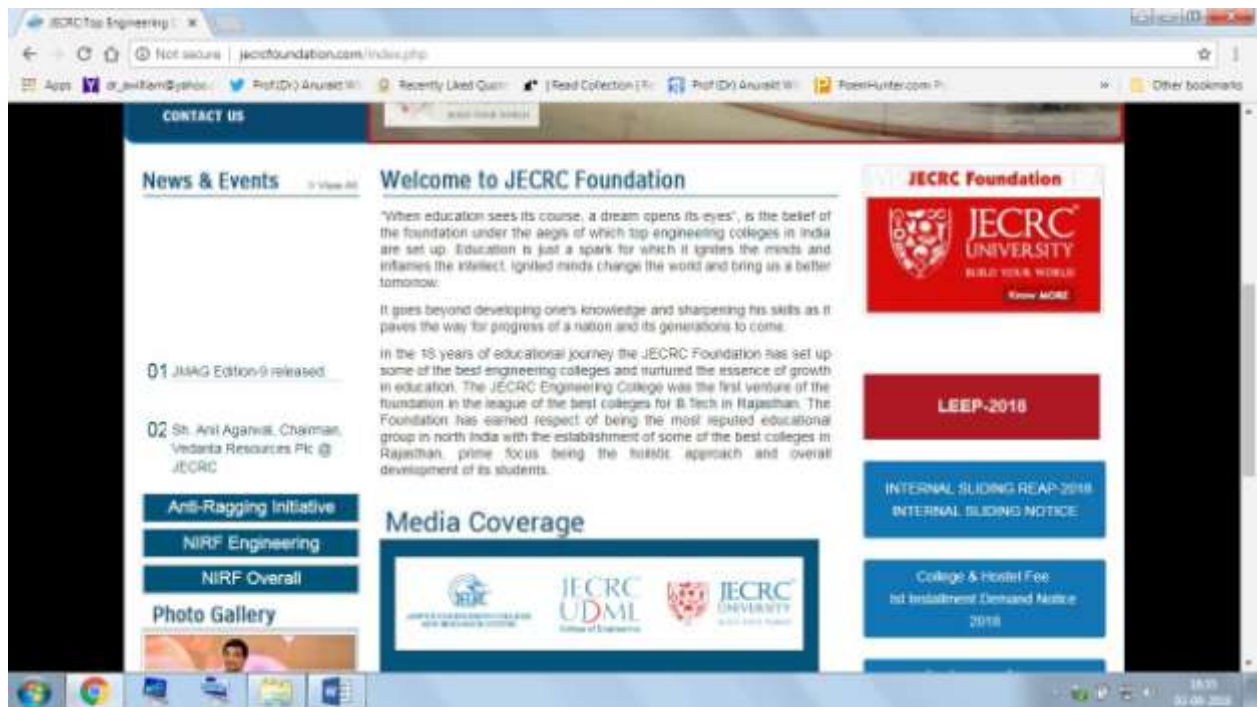

# [SELF ASSESSMENT REPORT]



The screenshot shows a web browser window with the URL `jecrc.in/pages/administration.php?section=anti-ragging`. The page features a header image of a panel of officials seated at a table. Below the image is a table titled "Anti-Ragging Committee" with the following data:

S.No.	Name	Designation	Mobile Number
1.	Dr. UK Pareek	Chief Proctor	9785506667
2.	Ms. Ruchi Mathur	Proctor	9828139024
3.	Mr. Arvind Mittal	Proctor	9772620462
4.	Ms. Shruti Kalra	Proctor	944371413
5.	Dr. M.P. Singh	Proctor	9442099039
6.	Dr. Anita Jain	Chief Librarian	9829030353
7.	Ms. Sanjay Raghav	Warden Girls Hostel	9982603534
8.	Mr. Bavi Bhatsnagar	Warden Girls Hostel	9982603534
9.	Sh. PK Gupta	Chief Warden/CAO	9982682475
10.	Sh. Ashok Sharma	Warden Boys Hostel	9982682914

## Library

The screenshot shows a web browser window with the URL `jecrc.in/pages/library.php?section=mission_vision`. The page features a header image of a panel of officials seated at a table. Below the image is a section titled "VISION and MISSION" with the following content:

**Vision**  
The vision of the library is to provide comprehensive resources and services in support of the research, teaching and learning needs of the college community.

**Mission**

- M1. Build connections and create tools to support teaching and learning.
- M2. Optimal use of available resources and services.
- M3. Ensure the preservation and long lasting availability of LRC resources.
- M4. Create attractive and comfortable physical and virtual environments for study and research.
- M5. Collaborate with faculty members and research scholars to enrich the collection and services.

# [SELF ASSESSMENT REPORT]



IECRC

IECRC Conference

to be updated at our...

Not secure | jecrc.in/pages/research.php?section=home

Apps | Inbox (26) - registrar | WELCOME TO PRE | Inbox - jecrcjapur | IECRC

Other bookmarks

### Spiritual Research Lab

In this fast paced world running behind the power of technology, there is a loss of awareness of self and the Supreme power. The meaning of life has changed in definition from happiness to luxury. A plan was created in IECRC to represent and re-establish the lost definition of self and broken connection with the Supreme. It has a special 'yoga' Meditation Room: Developed as silent time for meditation and self-contemplation. It also includes a Spiritual Library, with collection of best selling spiritual and inspirational books. Regular classes are conducted in English with audio in Bengali at a smart classroom. A Research Laboratory for conducting research on meditation is equipped with EEG, GSR, Emotionless, Scan, Hearting and other health monitoring devices. The Medical Approval, an. Chitra Mandal and an. Subhadra Devi are providing insight for the accomplishment of objective of the Spiritual Lab.

### Team @ Spiritual Research Lab

### Meditation Survey at College



A survey of Mindfulness of Faculty members was conducted using a psychological tool, Five Factor Mindfulness Questionnaire (FFMQ) in May 2018.

### Yoga Day at IECRC University



A one hour session was conducted on June 14, 2017 at Indian Yoga in Meditation at Spiritual Research Cell, IECRC Campus (Dr. Mahesh Agarwal, Asst. Prof. (IIT) conducted the session with meditation practitioners and Namas to Saraswati) Addressing Yoga and the benefits of meditation in daily life on the occasion of Yoga Day after the Yoga practice at IECRC students.

### Day of Giving First Anniversary of Spiritual Research Cell



During the Day of Giving week and on the first anniversary of the Spiritual Research Cell, on 4, 2017, a value based session for students of Darshan was organized where Shri Anup Agarwal, Director, IECRC, guided the session.

### Self-Engagement through Meditation

IECRC

IECRC Conference

to be updated at our...

Not secure | jecrc.in/pages/research.php?section=home

Apps | Inbox (26) - registrar | WELCOME TO PRE | Inbox - jecrcjapur | IECRC

Other bookmarks

### Self-Engagement through Meditation



An initiative of Day working from 10:00 a.m. to 11:00 a.m. for First Year students was organized for engagement through meditation. Special lecture, Prof. Dr. T. J. Singh, IECRC, addressed the students.

### AICTE Health Survey



During a workshop on Executive Leadership Program, Dec. 14 to 15, 2017, the team members and faculty staff members were invited for advanced health survey using the word and translation.

### Self-Engagement through Meditation - II



In continuation with the Workshop in December, second session of the session on Self-Engagement through meditation was conducted successfully with two batches for first year students during Feb. 15 to Feb. 16, 2018. Guest speaker: Rajendra K. K. Mishra was invited on the first day of the workshop for an interactive session on 'Meditation & Creativity'.

### Research Proceedings at London International Conference



Comparative analysis of mindfulness was presented at the international conference, IECRC International Congress on Information and Communication Technology: Facing it in 2018 February, 2018 in Brunel University, London and published in Springer Proceedings. It was found in this research study that meditation are more diverse and non-invasive than non-meditation. Hence, meditation helps in developing useful coping skills for successful and happy living.

### Yoga Class Among Smart India Hackathon



With the theme on the bright sunshine of March 21, 2018, participants were served with some yoga exercises and peaceful meditation. After the session, teams were again guided by the members and then they got back to their coding applications.



# [SELF ASSESSMENT REPORT]



**Jaipur Engineering College & Research Centre**

The JECRC Foundation ardently upholds the practice of self learning and intellectual growth, which are integral to education. Its premier college for B.Tech in Rajasthan. JECRC holds a commitment to offer the highest standards of education with state-of-the-art infrastructure.

Set up in the year 2000, The JECRC has a well-qualified and experienced faculty; excellent management and infrastructure, that ensure academic excellence and overall development of its students. The JECRC is the 'most preferred choice amongst the aspiring students for B.Tech. programmes. This is evident from the recent trends witnessed during the RPET and AIEEE/JEE counselling.

**Bachelor of Technology | B.Tech. Programe and Intake**

**Bachelor of Technology | B.Tech. Programe and Intake**

JECRC offers 4-year Bachelor of Technology (B.Tech.) degree programmes, which are approved by the All India Council for Technical Education (AICTE), New Delhi and affiliated to the Rajasthan Technical University, Kota, Rajasthan.

Programmes	Intake
Electronics & Communication Engineering	240
Electrical Engineering	120
Computer Science & Engineering	180
Information Technology	90
Mechanical Engineering	120
Civil Engineering	120
Lateral Entry (In 2nd year)	20% of 1st year Intake
Kashmiri Migrants	44
TFWS	50
Second Shift	
Mechanical Engineering	60
Computer Science & Engineering	60

**The JECRC Advantage**

**Cultural Fest-Renaissance**

The national level techno cultural fest of JECRC, Renaissance has made a niche for itself among all colleges in the

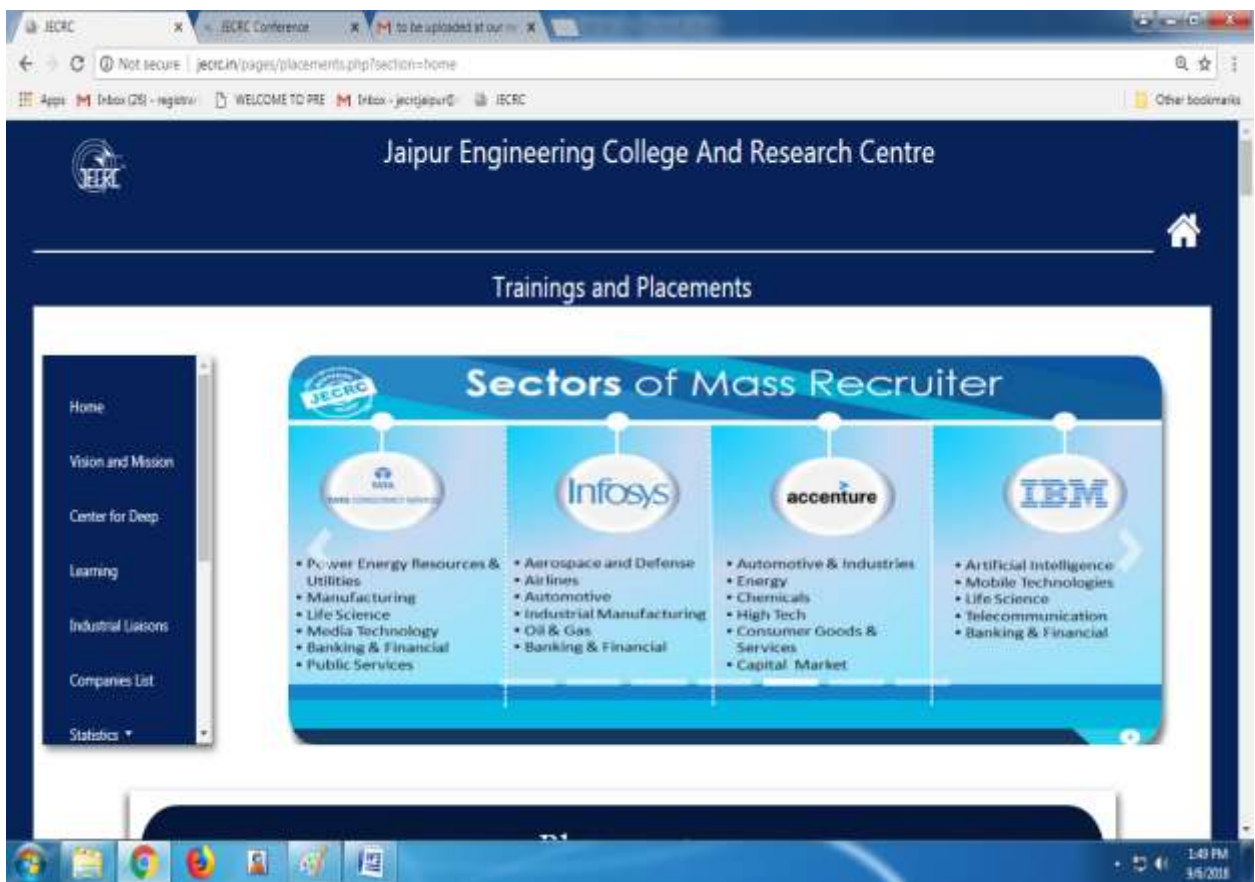

# [SELF ASSESSMENT REPORT]

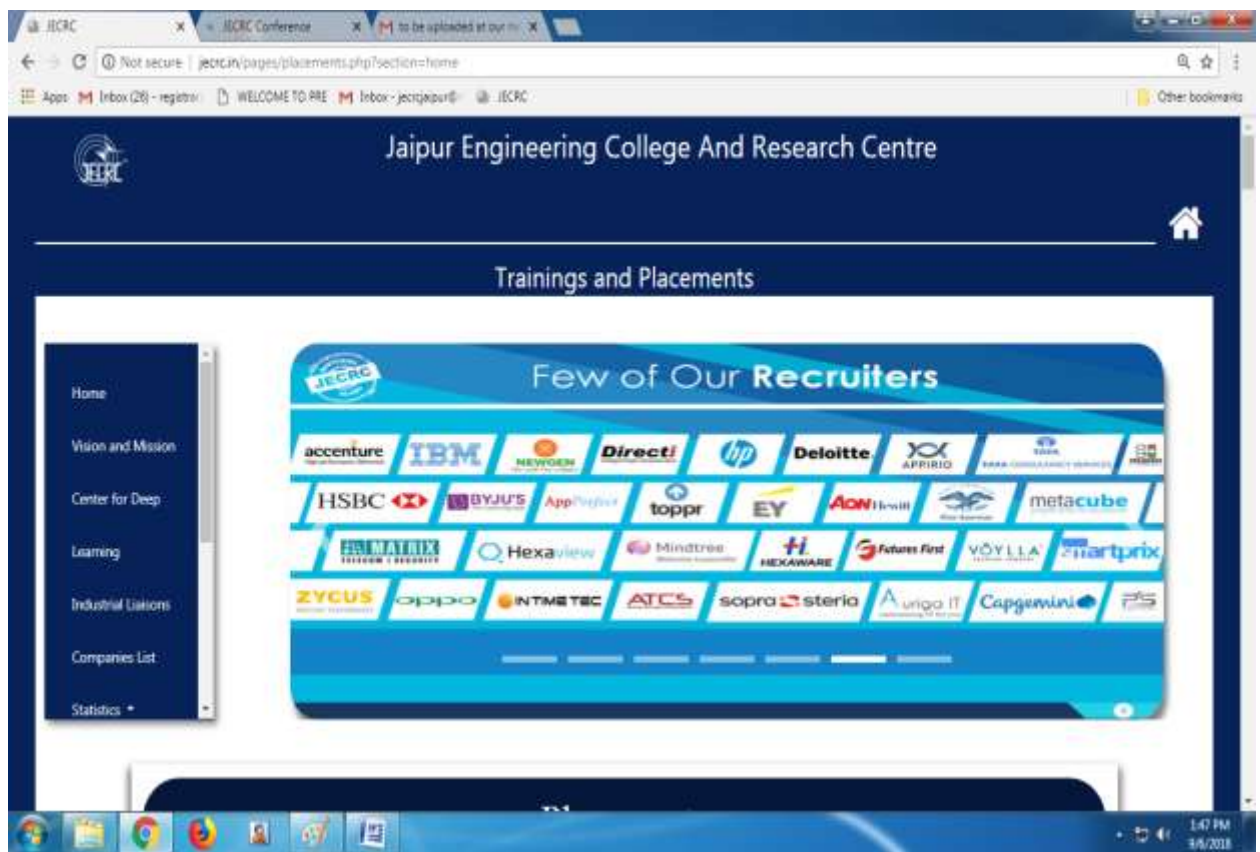
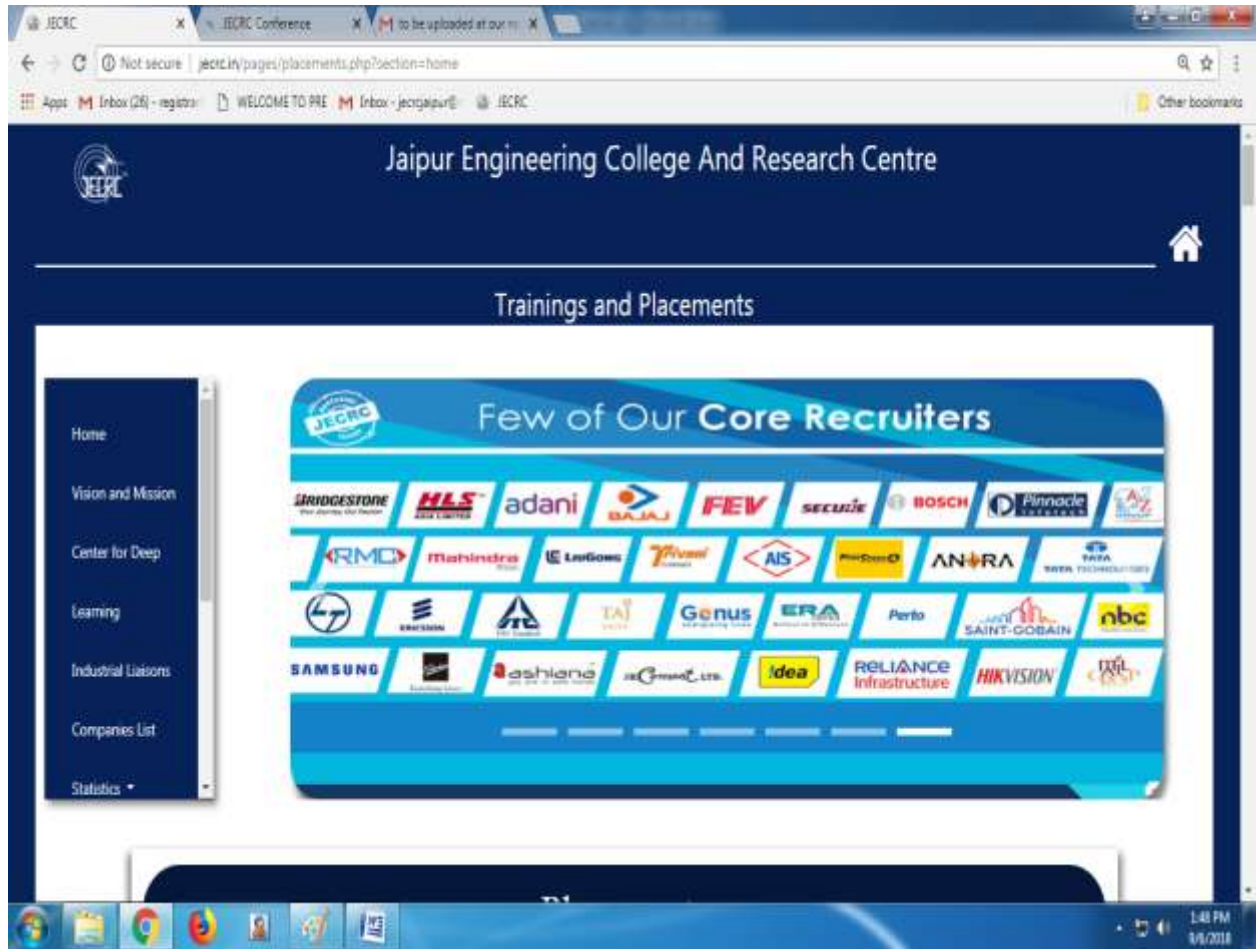

# [SELF ASSESSMENT REPORT]

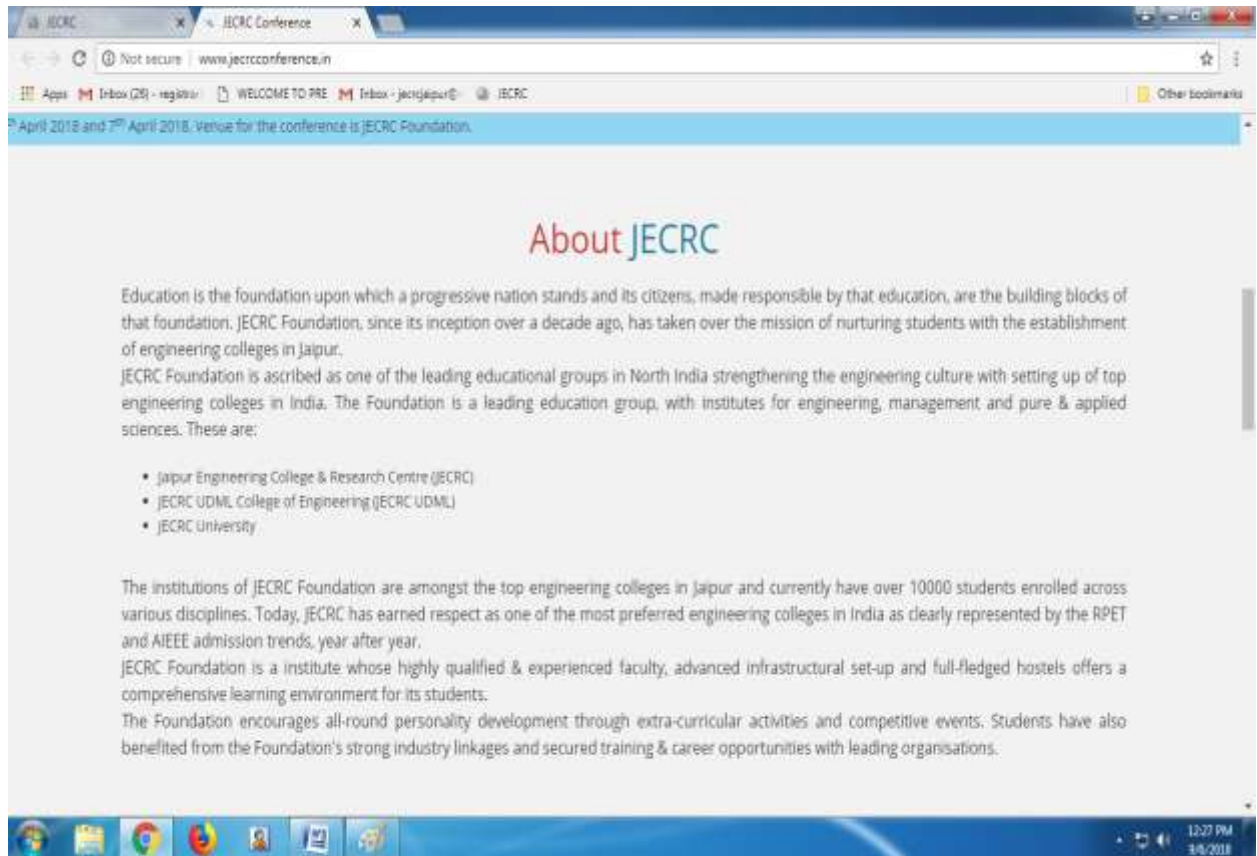

# [SELF ASSESSMENT REPORT]



Selected papers will be published in Springer Nature and UGC Approved Journals. The Conferences will held on 6<sup>th</sup> April 2018 and 7<sup>th</sup> April 2018. Venue for the conference:

APPLICATIONS & SECURITY (ICETEAS)	& 2018, February 18 <sup>th</sup>	Road, Jaipur-302 022	Details
INTERNATIONAL CONFERENCE ON INFORMATION TECHNOLOGY AND DIGITAL APPLICATIONS (ICITDA)	2018, April 6 <sup>th</sup> & 2018, April 7 <sup>th</sup>	JECRC Campus, Shri Ram ki Nargal, via Sitapura RICO Tonk Road, Jaipur-302 022	View Details
RECENT TECHNOLOGICAL DEVELOPMENTS IN ELECTRONICS & ELECTRICAL ENGINEERING (RTDEEE)	2018, April 6 <sup>th</sup> & 2018, April 7 <sup>th</sup>	JECRC Campus, Shri Ram ki Nargal, via Sitapura RICO Tonk Road, Jaipur-302 022	View Details
RECENT INNOVATIONS & TECHNOLOGICAL DEVELOPMENT IN MECHANICAL ENGINEERING (RTDME)	2018, April 6 <sup>th</sup> & 2018, April 7 <sup>th</sup>	JECRC Campus, Shri Ram ki Nargal, via Sitapura RICO Tonk Road, Jaipur-302 022	View Details
INTERNATIONAL CONFERENCE ON MATHEMATICAL MODELING AND COMPUTING (ICMMC)	2018, April 6 <sup>th</sup> & 2018, April 7 <sup>th</sup>	JECRC Campus, Shri Ram ki Nargal, via Sitapura RICO Tonk Road, Jaipur-302 022	View Details

Indexing by:

12:29 PM 4/5/2018

## College Broachers

**JECRC Foundation**  
www.jecrcfoundation.com

**18**  
Years of Nurturing Talent

**18 YEARS OF ACADEMIC EMINENCE**

**JECRC**  
JAIPUR ENGINEERING COLLEGE AND RESEARCH CENTRE

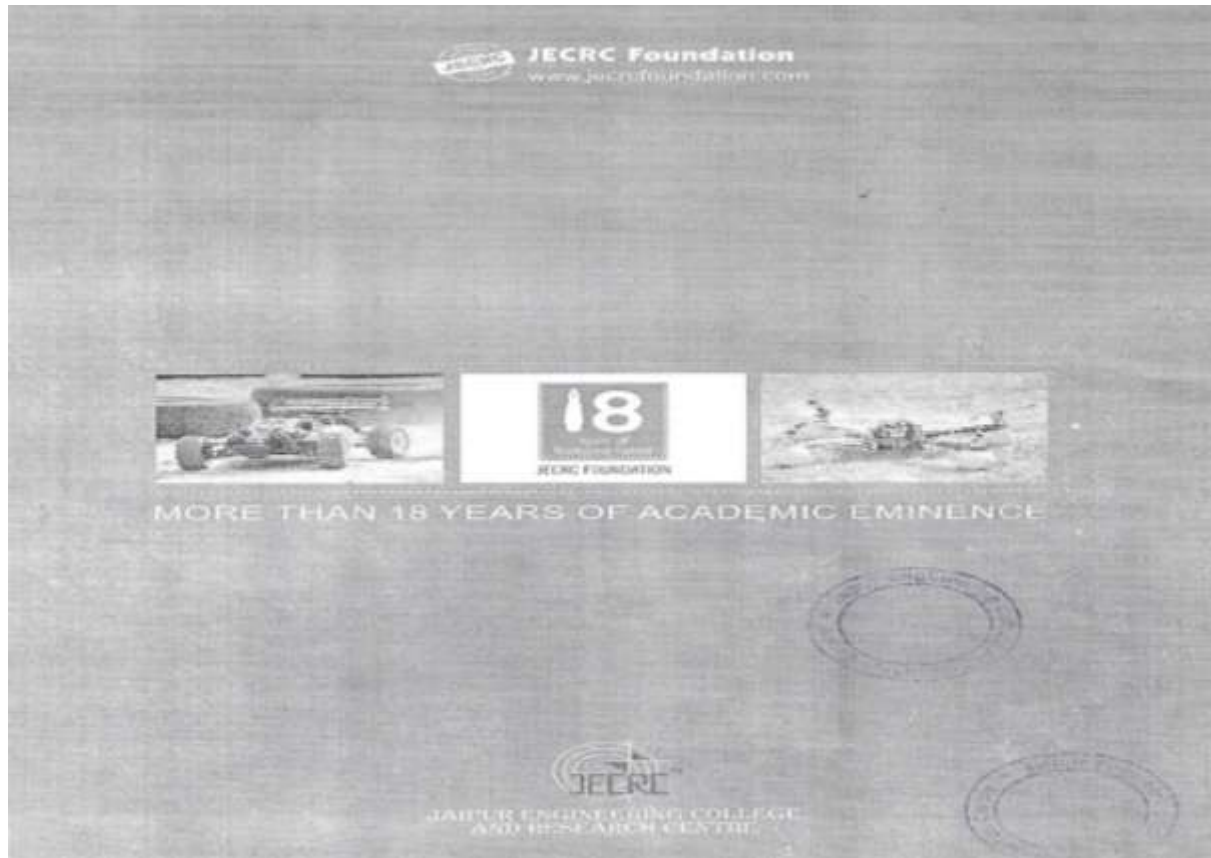

## INFORMATION FOR THE NEW ENTRANTS

### Vision of the Institute

To become a renowned centre of outcome based learning, and work towards academic, professional, cultural and social enrichment of the lives of individuals and communities.

### Mission of the Institute

- Focus on evaluation of learning outcomes and motivate students to inculcate research aptitude by project based learning.
- Identify, based on informed perception of Indian, regional and global needs, the areas of focus and provide platform to gain knowledge and solutions.
- Offer opportunities for interaction between academia and industry.
- Develop human potential to its fullest extent so that intellectually capable and imaginatively gifted leaders may emerge.

JECRC is a dream Institute for many aspirants where the ambiance is different from that of your school and provides platform to nurture overall development in education and extra-curricular activities. The management, faculty members, staff members and the students in the higher classes may expect you to behave like a grown-up and responsible citizen. During the tenure of your degree course, you have to take your own responsibility regarding required attendance in the college and participation in Co-curricular and Extra-curricular activities. If you are sincere towards studies and attend the theory, practical and tutorial classes regularly (the attendance should not be less than 75%) and take all the tests and examinations as per the requirement of the affiliating University, then not only your learning attribute will improve but also your performance to get your in the direction of higher studies/placements.

JECRC Institute promotes varied experiences and the outcome based teaching-learning provides the information about your learning outcomes. The information of different activities (academic and/or otherwise) is provided through the notices on the Notice Boards and also you have to be in constant touch with your mentor as assigned to you.

## [SELF ASSESSMENT REPORT]



Further, your efforts of getting more than 60% marks in aggregate without any back paper throughout will help you to access the platform to get placement in a reputed organization with higher salary package through campus interview selection process.

The institute will provide you the platform to groom yourself in various activities at leadership positions, also provide you the opportunity in the direction of lifelong learning, ethics, innovation, project management etc. along with technical knowledge.

To adapt yourself to the changed environment, you may consider the below mentioned points :

1. Inculcate the habit of coming to the college well-in-time and attend the all the classes regularly.
2. Wearing slippers are not allowed on the campus.
3. Wearing college identity card on the campus is compulsory
4. If you are commuting to the campus through two wheelers, wearing good quality helmet is compulsory even for pillion.
5. You may approach your mentor/proctor/HOD for any queries/concerns.
6. You should maintain the originality of your own personality and should not be unduly impressed or swayed by your friends in the College. You must know what is right/wrong for you.

I am sure, with these points of advice, you will smoothly sail through the transition period and emerge as an excellent professional.



**PRINCIPAL**



JAI PUR ENGINEERING COLLEGE  
AND RESEARCH CENTRE

## CONDUCT RULES AND GUIDELINES FOR STUDENTS

**A. Discipline and wisdom** are essential traits of a professional. Students of JECRC are expected to observe the highest standards of discipline.

**B. The following acts by a student shall be construed as indiscipline:**

1. **Misbehavior** with teachers, employees of the college, colleagues, girls students, juniors, wardens, proctors and visitors and acting against decorum in college premises-classrooms, laboratories, playgrounds, any type of transportation and hostels.
2. **Ragging** New Students.
3. Using **insulting, abusive and indecent language** in general and in the college premises and hostel, in particular.
4. **Damaging college property** including apparatus, books, fixtures and fittings, building, vehicles, fauna and flora in the college.
5. **Not attending class** and not participating in curricular activities as per the University ordinances.
6. **Not appearing in class tests and examinations.**
7. **Not paying attention to mentor** advice and warning notices.
8. **Wearing poor, indecent and Provocative dresses.**
9. **Coming late** to the college and leaving early.
10. **Leaving college premises or hostel without permission** of the Principal, Teacher, mentor, warden etc, as the case may be.
11. **Not paying dues and fee in time.**
12. **Not following the college calendar** and timing for co-curricular and extracurricular activities such as games and sports, cultural activities etc.
13. Forming clubs, association, society, forum or groups without the permission of appropriate authority such as Principal, Mentor, warden, proctor or other college authority.
14. **Spreading unfounded rumors** or canards, which may disrupt the college activities and disturb the college discipline.
15. **Using unfair means** in test and examinations.
16. **Causing injury to any person** or participating in acts of hooliganism within and outside the college campus and in public places such as roads, bus stand, cinema halls, railway station, airport, factories, restaurants, dhabas, hotels etc.
17. Indulge in any act, which may on investigation be confirmed as an act of indiscipline by the college or by Law.

**C. Reporting of Acts of Indiscipline**

The following will observe and report acts of indiscipline by the students to the Apex Disciplinary Committee consisting of the Senior Advisor, Principal, director HRD, one or more HODs and a member of the society or its nominee.

1. **Class/Subject teacher** : Late coming, shortage of attendance, indiscipline, ragging and lack of attentiveness or concentration in classes, indecent clothing, poor performance in test and examinations and laboratory activities and workshops.
2. **Mentor** : General behaviour of student with teachers, colleagues, employees etc.
3. **Warden** : Behaviour in hostels and default in paying dues.
4. **Librarian** : Behaviour in library, damages to books, theft of books etc.
5. **Proctor** : Late coming / early going, general behaviour in the campus with colleagues, teachers, employees etc. Discipline in the public place.
6. **Any employee** : Affected by an act of indiscipline.
7. **Any Student** : Affected by act of indiscipline.





# [SELF ASSESSMENT REPORT]



## D. Anti-Ragging Measures

- a) All students shall follow the UGC/AICTE Regulations on curbing the menace of Ragging in Higher Educational Institutions, 2009, State Government/RTU/College Authorities Guidelines etc. on the subject.
- b) Any violation of the guidelines would result in expulsion from the college besides the penal action as may be decided by the authorities in this regard.

## E. Penalty for acts of Indiscipline

When an act of indiscipline has been reported to the Apex Discipline Committee (ADC) a sub-committee formed by ADC shall investigate the reported act of indiscipline thoroughly and submit a detailed report on the incident.

The ADC will then examine the report and take suitable action against the incumbent depending on the severity of the act of indiscipline.

The following penalty may be imposed on a student.

1. Warning and Reprimand
2. Fine
3. Warning and Fine
4. Deduction of marks in DECA marks
5. Withholding permission to participate in an activity or examination
6. Rustication from the College for a certain period
7. Reporting to police if the act falls under penal law
8. Removal from hostel

## F. Some Specific Penalties

S. No.	Area of Indiscipline	PUNISHMENT (one or more)
1.	Class attendance less than 75%	Not allowed to appear in examinations
2.	Coming late to college	1. Warning 2. Deduction of discipline marks
3.	Damage to items and property	1. Recovery of cost 2. Appropriate fine
4.	Damage / Theft of Books	1. Warning 2. Recovery of double the cost of Book 3. Fine of Rs. 250/-
5.	Misbehavior	1. Warning 2. Fine of Rs. 1000/- to 2000/-
6.	Indiscipline in Hostel	1. Warning 2. Fine of Rs. 1000/- to 2000/- 3. Rustication from Hostel
7.	Unfair means in examinations	1. Action as per university rules including Police case
8.	Hooliganism / Ragging	1. Warning 2. Deduction of discipline marks 3. Police case 4. Fine that can go to even Rs. One Lakh 5. Rustication from the college



Principal



JAIPUR ENGINEERING COLLEGE  
AND RESEARCH CENTRE

## HOSTEL RULES AND REGULATIONS

### 1. General

- a) The hostel facility includes boarding and lodging and is meant for those students of JECRC Foundation who are not residents of Jaipur and are serious about their studies, can maintain proper discipline and decorum.
- b) Hostel facility may be provided to the students, who are of Jaipur only if spare capacity is available at the direction of administration.
- c) The rooms are double and triple seated with facilities such as cot, study table, chair and wardrobe. The students will have to bring their own mattress and pillow with linen.
- d) All residents of the hostel shall follow the hostel rules & regulations.
- e) Hostel room is allotted for the academic session i.e. beginning of session to 3 days after the last date of RTU exams.

### 2. Hostel Charges

- a) The annual hostel charges such as rent and boarding and other miscellaneous charges are decided by the College administration. Such charges are payable by the resident in two instalments. The first instalment is payable at the beginning of the session along with Rs. 5000/- as security deposit. The second instalment is payable as decided by the administration.
- b) If the dues are not paid timely, the membership for the hostel shall cease automatically and the student shall have to apply afresh for renewal /readmission.
- c) No refund shall be made by the college if a resident leaves the hostel before the expiry of the session, and the balance outstanding fee if any will be recoverable from the student.

### 3. Vacating the Hostel

- a) If a resident wishes to leave the hostel he/she will have to give one month's notice and will be allowed to leave only when the Principal and the Chief Warden/CAO give their permission. However, no claim for any refund of charges will be entertained.
- b) Further, if a resident is found or held guilty of indiscipline, ragging or any other such activity which is against the rules, norms and instructions of the institute, he/she shall be directed to leave the hostel by the Chief Warden/CAO. In such cases also there shall be no refund of any charges.
- c) Security charges of Rs. 5000/- will however be refunded after getting a no dues certificate from the Chief Warden/Warden.
- d) If a resident is found involved in ragging, his admission to the hostel and in the college will be cancelled and in view of Supreme Court's directives a case will be registered in the Police Station against him / her.

### 4. Mess Rules

- a) Residents shall take all their meals in the hostel mess. This includes breakfast, lunch, tea and dinner. Non-vegetarian meals or snacks including eggs shall neither be served nor be permitted.
- b) Residents will be served meals only during the prescribed timings as indicated below :

S.No.	Activites	Summer
1.	Breakfast	7.30 to 8.25 a.m.
2	Lunch	11.45 a.m. to 1.15 p.m.
3	Tea	5.30 to 6.00 p.m.
4	Dinner	8.00 to 9.00 p.m.

# [SELF ASSESSMENT REPORT]



- e) All residents shall be provided common menu.
- d) Residents shall not carry their meals wholly or in part, outside the mess. They shall not carry any utensil or other property of the mess outside the dining hall. In case of non-compliance, a fine of Rs. 50/- will be charged from the defaulters.
- e) Residents shall not interfere with cooking or other services and shall not handle mess equipment any time.
- f) Sick residents may be allowed to eat their meals in their rooms with the written permission of the warden.
- g) No outsider shall take breakfast, lunch, tea or dinner without prior written permission of the warden. If permitted, the host resident shall pay the charges in advance to the college through coupons available at college counter.
- h) Resident shall cooperate with the mess employees and deal with them in a polite and courteous manner.
- i) Residents shall pay their mess dues regularly as prescribed.
- j) Lodging and board facility may be made available during vacation provided atleast 60 of the residents stay in the hostel. No boarding charges will be refunded at any time once paid.
- k) Dress code - All residents will enter the hostel dining hall in proper presentable dress at all times. Students shall not be allowed to enter in bathroom slippers, shorts and sleeping suits.

## 5. Entry in / Out of Hostel

- a) The following timing shall be observed for maintenance of discipline in Hostel and Institute Campus.
  - a. Opening of Hostel Gate - 06.00 a.m.
  - b. Closing of Hostel Gate (Boys) - 09.30 p.m.
  - c. Closing of Hostel Gate (Girls) - 07.30 p.m. (Summer), 6.00 p.m. (Winter)
- b) Residents shall not go outside their rooms between 10:00 and 6:00 a.m. without permission of the Chief Warden/Warden I/C except for attending institute's functions or authorised academic work in the institute. Attendance may be taken during these hours.
- c) Residents shall not leave station without obtaining prior written permission of the warden. They shall report to the warden immediately on return.
- d) Residents shall not invite any unauthorised person in their hostel. They shall deal only with the authorized vendors, washermen, cobblers etc. during the prescribed hours any pay them at prescribed rates.
- e) Visit of outside person (including parents) to residents of hostel will be restricted up to the "Visitors room" only. No hosteller shall take his/her guest to his room in any circumstances. In exceptional circumstances, parents may be allowed to stay for a day in the guest room, on prior approval of Principal/CAO/Chief Warden, on payment of the prescribed charges which are presently Rs. 250/- per bed per day. In no case shall the parent stay in the hosteller's room.
- f) No visitors or parents are allowed to enter the hostel rooms in any case.
- g) No resident shall stay in the hostel during college hours without a valid reason which must be informed to warden. It is clarified that illness or health reason will be taken as a valid reason, Free period, visitors from outside etc. will not be taken as a valid reason.
- h) No day-scholar is permitted to enter the hostel during college hours. Suitable action and fine will be imposed upon him/her if reported by the Chief Warden/CAO.
- i) No resident shall leave the college campus without making necessary entries in the register kept with the guard at the college gate/hostel gate. After return he/she enter the time of return in the register.

## 6. Use & Facilities

- a) A student who has opted for hostel shall reside only in the hostel and the room allotted to him/her.
- b) Residents shall be responsible for all furniture, electrical and other fixtures in their rooms. They shall not

## [SELF ASSESSMENT REPORT]



disfigure or paint of stick photos, posters etc on walls, doors and windows or otherwise damage them. Failing Which Damage Charges Shall be levied per room. Residents are expected to maintain perfect discipline and proper atmosphere.

- c) Proper use of water and electricity shall be ensured and lights shall be switched off and taps closed when not in use. Defaulters shall be punished @ Rs 100/- per day
- d) Proper permission (at least 1 day in advance ) shall be taken in writing from warden for going to LG or home.
- e) Girls hostellers shall obtain a gate pass from the warden for going out of hostel/campus which shall be limited to 06 nos per month. First year girl hostellers are not allowed any outing in the first six months. However, to cater for any of their urgent legitimate requirements, a warden shall accompany/take them outside the campus once a fortnight, on Sunday for 3-4 hours.
- f) At the end of academic year or while leaving the institute, each resident shall handover the charge of his room with all furniture and fixture to hostel warden and pay the cost of all damages and shortage is detected in his her room. In case of non compliance a fine Rs. 250/- will be charged.
- g) Residents shall not use heaters or any other power appliance in their rooms.
- h) Use of alcoholic drinks or narcotic materials or gambling in any form is strictly prohibited in the hostel and institute premises. Defaulters shall be expelled from the hostel.
- i) Residents shall maintain decorum and dignity and shall not create any nuisance or disturbance for the neighbouring residents.
- j) Residents shall not organize any party assembly or activity in the hostel without the permission of the Principal.
- k) Residents shall not invite any speaker to address a hostel meeting without the permission of the Chief Warden/CAO/Principal.
- l) Residents shall not remove newspaper, magazine, furniture, radio, TV or games-material from the common rooms or mishandle or damage them.
- m) Residents shall cooperate with the Warden and fellow hostellers and obey warden's instructions on all matters concerning hostel/mess.

### 7. Problem Solving Committee

The residents would form a committee of three residents who would discuss the problems related to hostel every fortnight with the Chief Warden /CAO / Principal with facts and possible suggestions so that reasonable solutions could be found to their problems.

### 8. Rights of College Administration

- a) On matters not covered by these rules, the discretion of Warden/ Administration shall be final and binding.
- b) The college administration has full right to deny accommodation to any or all students at anytime in the overall interest of the college.
- c) The college administration reserves the right to change the rules and regulation in the overall interest of the college.

I have read & Understood the above

(Signature of Student)

(Signature of Parents)

Chief Warden / CAO

## LIBRARY RULES

### A. MEMBERSHIP

1. All the students of JECRC are members of the library.
2. Books will be issued only on presentation of the IDENTITY CARD.

### B. WORKING HOURS

1. The library will remain open from 8.15 to 8.00 pm. till further notice.
2. Issue and return services will be available between 8.30 am and 5.00 pm.

### C. PROCEDURE

1. Always-bring your "IDENTITY CARD" while you are in the library.
2. Keep you bags, file, books and other materials outside the library in the space provided.
3. Silence should be maintained while you are in the library. Please don't disturb the arrangement at your will.
4. Books will be issued for 14 days. The book should be returned to the library by the DUE DATE otherwise a sum of Rs. 1/- (Rupee one) per day per book will be charged as DUE OVER CHARGE.
5. Once issued the book will not be re-issued on the same day. If there is a demand from any other student, the same book will be retained and will be issued to that student.
6. Members can ask for a title not available in the library but required for academics work.
7. To recall any books before the due date.
8. REFERENCE BOOK'S DICTIONARIES, DIRECTORIES, PERIODICALS are not issuable. Members are expected to refer to the same in the library only.
9. Any damage done to the BOOK AND PERIODICAL replacement, the double cost will be charged along with a fine. Any kind of MARKING, WRITING OF NAME, FOLDING OF PAGES" will be treated as CAUSING DAMAGE".
10. The "RESERVE TEXT BOOK, REFERENCE BOOK" will be issued for reading room only on your identity card. If there is no reserve book please contact Librarian/Asstt. Librarian for help.
11. At the end of the session, every student should return the library cards before proceeding, failing which no new cards will be issued and a fine will be charged.
12. Students have to put their signature in the register available at the entrance of the library and show identity card. Without identity card, no entry will be allowed in the library.
13. Any student found not obeying the library rules and disturbing the library will be deprived of the library facility
14. Reader should observe strict silence inside the library.
15. User of mobile phone are not permitted in the library block.

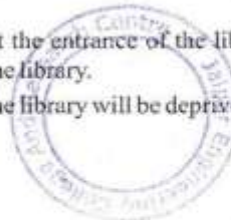

CHIEF LIBRARIAN



**TRANSPORT RULES & REGULATIONS**

1. Transport Fee for the entire session will be paid in advance at the beginning of the session.
2. Boarding in the bus will not be allowed without valid Identity card / Fee receipt for the current session.
3. Pickup time from every point is fixed and the bus will not wait at any pickup point.
4. Pickup point and bus route would be decide by the college administration. Every one is required to board the bus from a designated point only.
5. Bus facility is not available on Sunday/Holidays/during Vacation.
6. The college administration is not liable to provide alternative transport arrangement :-
  - (i) If a student is required to attend college during Sunday/Holiday/Vacation. Student will have to make his/her own arrangement to reach the college.
  - (ii) If a student misses the bus for any reason.
  - (iii) If the student is required to go to any other college for examination / other work.
7. The college management is not responsible for theft/loss of property during travel in bus.
8. In case of breakdown of the college bus, no charges towards alternative conveyance would be paid.
9. No one would be compensated for the distance covered by him/her for boarding the bus from designated point.
10. Ragging is strictly prohibited by law. Any student who is travelling in the college bus found indulging himself/herself directly/ indirectly in disciplinary activities like theft case/ ragging / fighting / quarrelling/ use of abusive language/ misbehave with fellow students, juniors/seniors and also with staff members, disciplinary action shall be initiated against him/her as deemed necessary or may be handed over to police for legal proceedings according to nature of offence for which entire responsibility will lie with the concerned student.
11. Every one is expected to maintain a proper discipline during the journey. Any loss or damage to college bus due to indisciplinary activities by a student during the journey will attract penalty as per rules.
12. The boarding is entirely at risk of the student availing transport faculty. The college administration does not own any type of responsibility towards compensation of any nature whatsoever.
13. Anit-Ragging Measures
  - a) all students using the bus facility shall follow the UGC/AICTE regulations on curbing the menace of Ragging in Higher Educational Institutions, 2009, state Government/RTU/College Authorities Guidelines etc. on the subject. The bus facility user student and his/her parent will have to submit separate undertakings in the form of affidavits, before making use of the bus facility.
  - b) Any violation of the gridlines would result in expulsion from the bus facility and/or college besides the penal action as may be decided by the authorities in this regard.
14. In case of any emergency, contact transport incharge.



Date .....

Signature of Parent/Guardian

Signature of Student

# [SELF ASSESSMENT REPORT]



## JAIPUR ENGINEERING COLLEGE AND RESEARCH CENTRE

Dear Students,

1. We welcome and congratulate you for seeking admission in this college. It is a fact that in this transitional phase you have left your school life and probably homely environment and would be entering into a new phase. Therefore, we would be more than willing to help you solving problems/difficulties, if any faced by you as a fresher and would extend all the necessary help.
2. To overcome the menace of ragging, college, administration has already made plans for FRESHERS' induction and orientation, which promote efficient and effective means of integrating. These plans will be communicated to you by the office shortly.
3. Besides, we all would ensure that ugly scar of ragging is obliterated from the face of all educational institutions. Here, we would like to inform you that you may turn up to the following persons in case of any help/guidance in the most unlikely event of the so-called ragging.

S.No.	Name	Designation	Mobile Number
1.	Dr. UK Pareek	Chief Proctor	9785506667
2.	Ms. Ruchi Mathur	Proctor	98281590XX
3.	Mr. Anshul Mittal	Proctor	9772620462
4.	Ms. Shruti Kalra	Proctor	9414371413
5.	Dr. M. P. Singh	Proctor	9414203639
6.	Dr. Anita Jain	Chief Librarian	9829230353
7.	Ms. Sanjay Raghav	Warden Girls Hostel	9982603534
8.	Mr. Ravi Bhatnagar	Transport Incharge	9024149459
9.	Sh. PK Gupta	Chief Warden/CAO	9982682475
10.	Sh. Ashok Sharma	Warden Boys Hostel	9982682914

4. You are instructed that you should desist from doing anything against your will even if required by the seniors and should not have any fear, as the institution cares for you and shall not tolerate any mischief against any student.
5. You are requested not to hesitate in seeking any help and guidance and to report any incidents of harassment, teasing etc., either as victim or even as a witness.

May I add that your college has always been ragging-free.

Wishing you a bright future in the college.

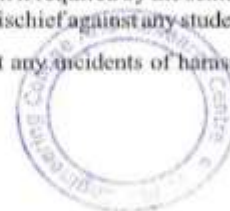

Principal



10.2. Budget Allocation, Utilization, and Public Accounting at Institute level Summary of current financial year's budget and actual expenditure incurred (for the institution exclusively) in the three previous financial years.

### BUDGET AND EXPENDITURE

#### Other then R&D

(in INR)

S.No.	Year	Budget	Total Expenditure	Expenditure by the Institute	Fund generated from other sources
1	2016-17	96,48,900	80,47,282	50,65,769	30,94,911
2	2017-18	1,70,65,541	1,53,70,784	81,79,279	73,91,115
3	2018-19 (Proposed)	2,05,05,170			

Training & Placement Budget for students : As per audited statement from accounts.

#### R&D Budget of institute for students

(in INR)

S.No.	Year	Budget	Total Expenditure	Expenditure by the Institute	Fund generated from other sources
1	2015-16	2,50,000	2,50,000	2,50,000	0
2	2016-17	5,00,000	4,97,600	4,97,600	0
3	2017-18	10,00,000	10,03,100	10,03,100	0
3	2018-19 (Proposed)	20,00,000			

V. [Signature]  
PRINCIPAL  
Jaipur Engineering College &  
Research Center  
Tonk Road, Jaipur - 303 905



# [SELF ASSESSMENT REPORT]



## Non Recurring Budget of the institute

(in INR)					
S.No.	Year	Budget	Total Expenditure	Expenditure by the Institute	Fund generated from other sources
1	2016-17	79,00,000 ✓	73,88,210	73,88,210	0
2	2017-18	81,00,000 ✓	68,92,020	68,92,020	0
3	2018-19 (Proposed)	85,00,000			

## Budget and Expenditure (year wise summary)

### Year 2016-17

(In INR)

S.No.	Branch/Section	Budget	Total Expenditure	Expenditure by the Institute	Fund generated from other sources
1	Computer Science & Engineering	2148200	1570026	1233095	336931
2	Electrical Engineering	121500	55386	25734	29652
3	Civil Engineering	24000	23813	13813	10000
4	Electronics & Communication Engineering	813200	481715	156698	360950
5	Information Technology	119000	105027	1711	104450
6	Mechanical Engineering	407300	308069	105500	278900
7	First Year	537100	545024	43439	501585
8	Alumni Annual budget	352500	337478	337478	0
9	JECRC MUN	411000	372331	95000	277331
10	Soch	87000	86000	33000	53000
11	Zarurat	350000	317500	215000	102500
12	Aashayein	125000	105116	95736	9380
13	Suhasini	18000	15350	3900	11450
14	Library	700000	477100	477100	0
15	Sports	150000	125263	77063	48200
16	Student Development Cell	557100	523114	523114	0
17	Other Activities at College level	2728000	2598970	1628388	970582
<b>Total</b>		<b>96,48,900</b>	<b>80,47,282</b>	<b>50,65,769</b>	<b>30,94,911</b>

Difference of Total Expenditure: Expenditure by the institute and Fund generated from other sources is the seed money for the upcoming events.

*V. P. Rao*  
PRINCIPAL

31

# [SELF ASSESSMENT REPORT]



Year 2017-18

(In INR)

S.No.	Branch/Section	Budget	Total Expenditure	Expenditure by the Institute	Fund generated from other sources
1	Computer Science & Engineering	3469800	3052595	2187173	865422
2	Electrical Engineering	343725	241134	42585	198549
3	Civil Engineering	1548000	1503364	15408	1487956
4	Electronics & Communication Engineering	2952900	2654761	1644598	1103670
5	Information Technology	645700	450022	133924	361500
6	Mechanical Engineering	1502770	1338669	828870	570500
7	First Year	404860	264987	47987	217000
8	Alumni Annual Budget	143500	147006	147006	0
9	JECRC MUN	403786	375144	101813	273331
10	Soch	60500	59000	13500	45500
11	Zarurat	332500	286300	168050	118250
12	Aashayein	189500	180900	180900	0
13	Suhasini	24000	21500	9000	12500
14	Library	700000	634300	634300	0
15	Sports	150000	130659	75659	55000
16	Student Development Cell	619000	578315	578315	0
16	Other Activities at College level	3575000	3452128	1370191	2081937
Total		1,70,65,541	1,53,70,784	81,79,279	73,91,115

Difference of Total Expenditure: Expenditure by the institute and Fund generated from other sources is the seed money for the upcoming events.

  
PRINCIPAL  
Jaipur Engineering College &  
Research Center.

32

# [SELF ASSESSMENT REPORT]



## Proposed Year 2018-19

(In INR)

S.No.	Branch/Section	Budget	Total Expenditure	Expenditure by the Institute	Fund generated from other sources
1	Computer Science & Engineering	7550000			
2	Electrical Engineering	692950			
3	Civil Engineering	177720			
4	Electronics & Communication Engineering	1965000			
5	Information Technology	950000			
6	Mechanical Engineering	1372000			
7	First Year	424000			
8	Alumni Annual Budget	200000			
9	JECRC MUN	421000			
10	Soch	70000			
11	Zarurat	350000			
12	Aashayein	145000			
13	Suhasini	42500			
14	Library	1000000			
15	Sports	180000			
16	Student Development Cell	675000			
17	Other Activities at College level	4290000			
	<b>Total</b>	<b>2,05,05,170</b>			

V. Patel

PRINCIPAL  
Jaipur Engineering College &  
Research Center

Tank Road, Jaipur - 302 005

33

# [SELF ASSESSMENT REPORT]



## 10.3. Program Specific Budget Allocation, Utilization

### Computer Science & Engineering

Year 2016-17

(In INR)

S.No.	Activity	Budget	Total Expenditure	Expenditure by the Institute	Fund generated from other sources
1	Curricular Activity	84400	80129	6100	74029
2	Co-Curricular Activity	288800	267902	5000	262902
3	Consumable Items	1275000	842943	842943	0
4	Non Consumable Items	500000	379052	379052	0
<b>Total</b>		<b>21,48,200</b>	<b>15,70,026</b>	<b>12,33,095</b>	<b>3,36,931</b>

Year 2017-18

S.No.	Activity	Budget	Total Expenditure	Expenditure by the Institute	Fund generated from other sources
1	Curricular Activity	1401800	1135742	270800	864942
2	Co-Curricular Activity	18000	17355	16875	480
3	Consumable Items	1500000	1351209	1351209	0
4	Non Consumable Items	550000	548289	548289	0
<b>Total</b>		<b>34,69,800</b>	<b>30,52,595</b>	<b>21,87,173</b>	<b>8,65,422</b>

Proposed for Year 2018-19

S.No.	Activity	Proposed Budget	Total Expenditure	Expenditure by the Institute	Fund generated from other sources
1	Curricular Activity	2300000			
2	Co-Curricular Activity	200000			
3	Consumable Items	1550000			
4	Non Consumable Items	3500000			
<b>Total</b>		<b>75,50,000</b>			

*V. B. Gaur*  
PRINCIPAL  
Jaipur Engineering College &  
Research Center  
Tonk Road, Jaipur - 303 905

# [SELF ASSESSMENT REPORT]



## Information Technology

Year 2016-17

(In INR)

S.No.	Activity	Budget	Total Expenditure	Expenditure by the Institute	Fund generated from other sources
1	Curricular Activity	19000	14210	1711	13550
2	Co-Curricular Activity	100000	90817	0	90900
<b>Total</b>		<b>1,19,000</b>	<b>1,05,027</b>	<b>1,711</b>	<b>1,04,450</b>

Year 2017-18

S.No.	Activity	Budget	Total Expenditure	Expenditure by the Institute	Fund generated from other sources
1	Curricular Activity	605700	418937	133924	330500
2	Co-Curricular Activity	40000	31085	0	31000
<b>Total</b>		<b>6,45,700</b>	<b>4,50,022</b>	<b>1,33,924</b>	<b>3,61,500</b>

Proposed Year 2018-19

S.No.	Activity	Budget	Total Expenditure	Expenditure by the Institute	Fund generated from other sources
1	Curricular Activity	950000			
2	Co-Curricular Activity	0			
<b>Total</b>		<b>9,50,000</b>			

*V. Patel*

Consumable and non consumable items are taken care with the Computer Science & Engineering budget.

PRINCIPAL  
Jaipur Engineering College &  
Research Center  
Tonk Road, Jaipur - 303 905

# [SELF ASSESSMENT REPORT]



## Electrical Engineering

Year 2016-17

(In INR)

S.No.	Activity	Budget	Total Expenditure	Expenditure by the Institute	Fund generated from other sources
1	Curricular Activity	56500	50452	20800	29652
2	Co-Curricular Activity	0	0	0	0
3	Consumable Items	15000	4934	4934	0
4	Non Consumable Items	50000	0	0	0
<b>Total</b>		<b>1,21,500</b>	<b>55,386</b>	<b>25,734</b>	<b>29,652</b>

Year 2017-18

S.No.	Activity	Budget	Total Expenditure	Expenditure by the Institute	Fund generated from other sources
1	Curricular Activity	276525	238094	41745	196349
2	Co-Curricular Activity	2200	2200	0	2200
3	Consumable Items	15000	840	840	0
4	Non Consumable Items	50000	0	0	0
<b>Total</b>		<b>3,43,725</b>	<b>2,41,134</b>	<b>42,585</b>	<b>1,98,549</b>

Proposed Year 2018-19

S.No.	Activity	Budget	Total Expenditure	Expenditure by the Institute	Fund generated from other sources
1	Curricular Activity	685000			
2	Co-Curricular Activity	0			
3	Consumable Items	7950			
4	Non Consumable Items	0			
<b>Total</b>		<b>6,92,950</b>			

*V. Pawar*  
PRINCIPAL  
Jaipur Engineering College &  
Research Center  
Tonk Road, Jaipur - 303 905

# [SELF ASSESSMENT REPORT]



## Mechanical Engineering

### Year 2016-17

(In INR)

S.No.	Activity	Budget	Total Expenditure	Expenditure by the Institute	Fund generated from other sources
1	Curricular Activity	218500	131500	3500	202000
2	Co-Curricular Activity	78800	74569	0	76900
3	Consumable Items	110000	102000	102000	0
4	Non consumable items				
<b>Total</b>		<b>4,07,300</b>	<b>3,08,069</b>	<b>1,05,500</b>	<b>2,78,900</b>

### Year 2017-18

S.No.	Activity	Budget	Total Expenditure	Expenditure by the Institute	Fund generated from other sources
1	Curricular Activity	583500	450000	4000	495000
2	Co-Curricular Activity	71000	63799	0	75500
3	Consumable Items	123270	93270	93270	0
4	Non consumable Items	725000	731600	731600	0
<b>Total</b>		<b>15,02,770</b>	<b>13,38,669</b>	<b>8,28,870</b>	<b>5,70,500</b>

### Proposed Year 2018-19

S.No.	Activity	Budget	Total Expenditure	Expenditure by the Institute	Fund generated from other sources
1	Curricular Activity	315000			
2	Co-Curricular Activity	120000			
3	Consumable Items	187000			
4	Non Consumable items	750000			
<b>Total</b>		<b>13,72,000</b>			

V. @  
PRINCIPAL  
Jaipur Engineering College &  
Research Center  
Tonk Road, Jaipur - 303 905

# [SELF ASSESSMENT REPORT]



## Civil Engineering

### Year 2016-17

(In INR)

S.No.	Activity	Budget	Total Expenditure	Expenditure by the Institute	Fund generated from other sources
1	Curricular Activity	15000	15000	5000	10000
2	Co-Curricular Activity	0	0	0	0
3	Consumable Items	9000	8813	8813	0
4	Non Consumable Items	0	0	0	0
<b>Total</b>		<b>24,000</b>	<b>23,813</b>	<b>13,813</b>	<b>10,000</b>

### Year 2017-18

S.No.	Activity	Budget	Total Expenditure	Expenditure by the Institute	Fund generated from other sources
1	Curricular Activity	82000	81081	0	81081
2	Co-Curricular Activity	0	0	0	0
3	Consumable Items	16000	15408	15408	0
4	Non Consumable	1450000	1406875	0	1406875
<b>Total</b>		<b>15,48,000</b>	<b>15,03,364</b>	<b>15,408</b>	<b>14,87,956</b>

### Proposed Year 2018-19

S.No.	Activity	Budget	Total Expenditure	Expenditure by the Institute	Fund generated from other sources
1	Curricular Activity	100000			
2	Co-Curricular Activity	0			
3	Consumable Items	77720			
4	Non Consumable Items	0			
<b>Total</b>		<b>1,77,720</b>			

V. K. S.  
PRINCIPAL  
Jaipur Engineering College &  
Research Centre  
Tonk Road, Jaipur - 302 005



# [SELF ASSESSMENT REPORT]



## Electronics & Communication Engineering

Year 2016-17

(In INR)

S.No.	Activity	Budget	Total Expenditure	Expenditure by the Institute	Fund generated from other sources
1	Curricular Activity	303200	325017	0	360950
2	Co-Curricular Activity	0	0	0	0
3	Consumable Items	10000	2463	2463	0
4	Non consumable Items	500000	154235	154235	0
<b>Total</b>		<b>8,13,200</b>	<b>4,81,715</b>	<b>1,56,698</b>	<b>3,60,950</b>

Year 2017-18

S.No.	Activity	Budget	Total Expenditure	Expenditure by the Institute	Fund generated from other sources
1	Curricular Activity	1327900	1010163	0	1103670
2	Co-Curricular Activity	0	0	0	0
3	Consumable Items	25000	11648	11648	0
4	Non consumable Items	1600000	1632950	1632950	0
<b>Total</b>		<b>29,52,900</b>	<b>26,54,761</b>	<b>16,44,598</b>	<b>11,03,670</b>

Proposed Year 2018-19

S.No.	Activity	Budget	Total Expenditure	Expenditure by the Institute	Fund generated from other sources
1	Curricular Activity	1340000			
2	Co-Curricular Activity	0			
3	Consumable Items	25000			
4	Non consumable Items	600000			
<b>Total</b>		<b>19,65,000</b>			

*V. Patel*

PRINCIPAL  
Jaipur Engineering College &  
Research Centre  
Tonk Road, Jaipur - 303 905

# [SELF ASSESSMENT REPORT]



## I Year

Year 2016-17

(In INR)

S.No.	Activity	Budget	Total Expenditure	Expenditure by the Institute	Fund generated from other sources
1	Curricular Activity	286000	303800	0	303800
2	Co-Curricular Activity	26100	25873	2323	23550
3	Consumable Items	141000	139689	28349	111340
4	Non Consumable Items	84000	75662	12767	62895
<b>Total</b>		<b>5,37,100</b>	<b>5,45,024</b>	<b>43,439</b>	<b>5,01,585</b>

Year 2017-18

S.No.	Activity	Budget	Total Expenditure	Expenditure by the Institute	Fund generated from other sources
1	Curricular Activity	288660	173750	0	173750
2	Co-Curricular Activity	40400	44800	1550	43250
3	Consumable Items	73000	45547	45547	0
4	Non Consumable Items	2800	890	890	0
<b>Total</b>		<b>404860</b>	<b>264987</b>	<b>47987</b>	<b>217000</b>

Proposed Year 2018-19

S.No.	Activity	Budget	Total Expenditure	Expenditure by the Institute	Fund generated from other sources
1	Curricular Activity	323000			
2	Co-Curricular Activity	10000			
3	Consumable Items	81000			
4	Non Consumable Items	10000			
<b>Total</b>		<b>4,24,000</b>			

V. R. R.  
PRINCIPAL  
Jaipur Engineering College &  
Research Center  
Tonk Road, Jaipur - 303 905

# [SELF ASSESSMENT REPORT]



## Utilization of allocated funds

### Budget and Expenditure - Non Recurring

#### Year 2016-17

(In INR)

S.No.	Branch/Section	Budget	Total Expenditure	Expenditure by the Institute	Fund generated from other sources
1	Deepawali Gifts to the staff members	1000000	917520	917520	0
2	Tent and others	200000	200000	200000	0
3	Printing (Banner, Posters, Brochures etc.)	1200000	1183321	1183321	0
4	Civil Maintenance	5500000	5087369	5087369	0
<b>Total</b>		<b>79,00,000</b>	<b>73,88,210</b> ✓	<b>73,88,210</b>	<b>0</b>

#### Year 2017-18

S.No.	Branch/Section	Budget	Total Expenditure	Expenditure by the Institute	Fund generated from other sources
1	Deepawali Gifts to the staff members	1000000	1000000	1000000	0
2	Tent and others	1000000	940000	940000	0
3	Printing (Banner, Posters, Brochures etc.)	1100000	1147973	1147973	0
4	Civil Maintenance	5000000	3804047	3804047	0
<b>Total</b>		<b>81,00,000</b>	<b>68,92,020</b> ✓	<b>68,92,020</b>	<b>0</b>

*V. Pan*  
PRINCIPAL  
Jaipur Engineering College &  
Research Center  
Tonk Road, Jaipur - 303 905

# [SELF ASSESSMENT REPORT]



## Proposed 2018-19

(In INR)

S.No.	Branch/Section	Budget	Total Expenditure	Expenditure by the Institute	Fund generated from other sources
1	Deepawali Gifts to the staff members	1000000			
2	Tent and others	1000000			
3	Printing (Banner, Posters, Brochures etc.)	1500000			
4	Civil Maintenance	5000000			
<b>Total</b>		<b>85,00,000</b>			

*V. P. Singh*

PRINCIPAL  
Jaipur Engineering College &  
Research Center  
Tonk Road, Jaipur - 303 905

**CONTENT BEYOND SYLLABUS**

**(1) By the Industries**

S. No.	Training	SPOC	Starting date	Last date	No. of Students	Fee collected (Rs.)	
1	Linux - Red Hat-I	ECE/CS	17.01.18	26.01.18	173 (CS-119, IT-21, EE-4, ECE-29)	34600	
2	Linux - Red Hat-II	ECE/CS	19.02.2018	28.02.2018	62 (40-CS, 8-EC, 14-IT)	12400	
3	Customer Relationship Management - Sales force	IT	17.01.18	22.3.2018	111 (CS-74, IT-33, EE-01, ECE-03)	444000	
4	Apps & Ideas	ECE,ME	07.09.17	15.02.18	17 (EC-6, CS-8, IT-1, ME-2)	51000	
5	Robotics - SakRobotics	ECE	19.01.18	22.01.18	66 (EC-11, 1 yr -55)	99000	
6	Embedded System-Techiest-Slot 1	ECE	22.01.18	15.3.2018	35-EC	175000	
7	Embedded System-Techiest-Slot 2	ECE	8.2.2018	5.4.2018	21-EC	105000	
8	AutoCAD	CE	12.3.2018	16.4.2018	16-CE	56000	
9	AutoCAD, Solidworks and Aaxys Software-CADD centre	ME	29.1.2018	21.4.2018	38-ME	296000	
10	Machine learning and IOT-Forak	CS	01.02.18	22.3.2018	27 (CS-9,IT-9,EC-8, EE-1)	132300	
11	Core JAVA and Android	EE	9.2.2018	21.4.2018	42-EE	126000	
12	Expert Lectures - Engineers Academy	Expert Lectures in each branch, January-March 2018					Free
Total Rs.						15,31,800	

**(2) By the Faculty Members**

S. No.	Training	SPOC	Starting date	Last date	No. of Students	Fee collected
1	Python	IT	17.01.18	15.02.18	33-IT	Free
2	Organization of student developer (OSD)	IT	18.01.18	20.03.18	11-IT	Free
3	C, C++	CSE	22.01.18	--	22- CS	Free

  
 PRINCIPAL  
 Jaipur Engineering College &  
 Bikaner's Cluster  
 ,Tonk Road, Jaipur- 302 905

**RESEARCH GRANTS**

S.No.	Topic	Agency	Amount (Rs.)	Remarks
1	Rural Technology Business Incubation (RTBI)	DST Rajasthan	30,00,000	F.No. 15(2)DST/EDP-SDP/2016-17/Part 1/3432 dt 25.01.18
2	Validation and scientific basis of meditation and omics and their role as therapeutic targets	DST CSRI	42,56,400	File No. SR/CSRI/131/2012

  
 PRINCIPAL  
 Jaipur Engineering College &  
 Research Center  
 Tonk Road, Jaipur - 303 905

**PROPOSED FDP/WORKSHOP/SEMINAR**  
**2018-19**

**1. By the RTU Kota**

S. No.	Topic	Agency	Amount (Rs.)	Remarks
1	Mathematical Modelling and optimization of industrial problems	TEQIP III - RTU (ATU)	2,00,000	No. RTU/TEQIP-III/F(56)/2017-18/114-22 dt 23.02.18
2	Smart India Hackathon and Innovation & Startup competition	TEQIP III - RTU (ATU)	Budget yet to finalize by the RTU. Our request for Rs. 10 Laacs send to RTU	No. RTU/TEQIP-III/F (56)/2017-18/1272-81 dt 25.04.18
3	MOOCs and Digital Content Development	TEQIP III - RTU (ATU)	2,00,000	RTU/TEQIP-III/F(56)/2017-18/284-292 dt 30.04.18
4	Business Entrepreneurship Development (BED Lab)	TEQIP III - RTU (ATU)	4,77,500	Activity during 18-22 Dec. 18
5	Art of Innovative & Impactful Teaching	TEQIP III - RTU (ATU)	4,77,500	Activity during 25-29 Sep 18
6	Emerging trends in optical fiber and photonics for future communication systems	TEQIP III - RTU (ATU)	4,77,500	Activity during Aug 28 - 1 Sep 18
7	Renewable Energy Management and techniques for a sustainable future	TEQIP III - RTU (ATU)	4,77,500	Activity during 12-16 Nov 18

  
 PRINCIPAL  
 Jaipur Engineering College &  
 Research Center  
 Tonk Road, Jaipur - 303 905

# [SELF ASSESSMENT REPORT]



## PROPOSAL SENT TO THE GOVERNMENT AGENCIES FOR DIFFERENT ACTIVITIES

S. No.	Date of submission	Funding agency	Project	Funding amount (Rs.)	Remarks
1	22/12/2016	NSTMIS, Deptt. of Sci. & Tech., New Delhi	Quantitative and Qualitative Assessment of Drivers and Barriers to Green Manufacturing in the state of Rajasthan	46,38,700	Not approved
2	10/01/2018	RTU Kota	Third International Congress on Information and Communication Technology (ICICT)-2018 at UK London	12,10,000	
3	29/11/2017	AICTE, New Delhi	Grant for conference ICETEAS-2018	5,00,000	
4	30/11/2017	AICTE, New Delhi	TA grant for ICICT-2018 UK London – Dr. V.K. Chandna	2,20,000	
5	30/11/2017	AICTE, New Delhi	TA grant for ICICT-2018 UK London – Dr. V.S. Rathore	2,20,000	

  
PRINCIPAL  
Jaipur Engineering College &  
Research Centre  
Jank Road, Jaipur - 300 905

## CONSULTANCY

	2014-15	2015-16	2016-17
Total number of consultancy projects	18	10	22
Total number of client organizations	02	02	15
Amount	3,90,750.00	2,62,630.00	2,30,401.00

  
PRINCIPAL  
Jaipur Engineering College &  
Research Centre  
Jank Road, Jaipur - 300 905

# [SELF ASSESSMENT REPORT]



ii. TEQIP Activities by RTU Kota

S.No.	Activity	Date	Budget Amount	Reference No.
1	Smart India Hackathon and Innovation & Startup competition	Dec. 2018	Yet to finalize by the RTU Committee	No. RTU/TEQIP-III/F (56)/2017-18/1272-81 dt 25.04.18
2	MOOCs and Digital Content Development	20-21 Dec 2019	Rs. 2,00,000	RTU/TEQIP-III/F(56)/2017-18/284-292 dt 30.04.18

*V. @ w*

**The audited statements**

2014-2015

JAIPUR ENGINEERING COLLEGE AND RESEARCH CENTRE  
JAIPUR

Sr. No.	Items	Budgeted	Actual Expenses
2014-15			
1	Infrastructure Built Up.	8,00,00,000	7,52,10,320
2	Library	4,00,000	3,91,210
3	Laboratory Equipments	20,00,000	21,40,919
4	Laboratory Consumables	4,50,000	4,63,736
5	Teaching and Non Teaching Staff Salary	10,00,00,000	10,00,16,936
6	Maintenance and Spares	90,00,000	94,48,551
7	R & D	2,50,000	68,200
8	Training & Travel	5,00,000	6,05,514
		<b>19,26,00,000</b>	<b>18,83,45,386</b>

*Signed*  
Accounts Officer  
20-4-15

2015-2016

JAIPUR ENGINEERING COLLEGE AND RESEARCH CENTRE  
JAIPUR

Sr. No.	Items	Budgeted	Actual Expenses
2015-16			
1	Infrastructure Built Up.	8,00,00,000	6,34,63,541
2	Library	4,00,000	3,43,271
3	Laboratory Equipments	4,00,000	4,49,982
4	Laboratory Consumables	1,25,000	1,34,005
5	Teaching and Non Teaching Staff Salary	11,00,00,000	11,23,12,336
6	Maintenance and Spares	65,00,000	68,52,453
7	R & D	2,50,000	2,88,050
8	Training & Travel	15,00,000	17,00,310
		<b>19,91,75,000</b>	<b>18,53,43,948</b>

*Signed*  
Accounts Officer  
24-5-16



# [SELF ASSESSMENT REPORT]



## Audited statement from Accounts

Sr. No.	Items	Budgeted	Actual Expenses
<b>2016-2017</b>			
1	Infrastructure Built Up	10,00,00,000.00	9,67,79,760.00
2	Library	2,00,000.00	1,95,808.00
3	Laboratory Equipments	0.00	0.00
4	Laboratory Consumables	1,50,000.00	1,54,970.00
5	Teaching & Non Teaching Staff Salary	13,00,00,000.00	13,37,26,913.00
6	Maintenance & Spares	50,00,000.00	50,87,369.00
7	R & D	0.00	0.00
8	Training & Travel	15,00,000.00	- 14,97,872.00
Total		23,68,50,000.00	23,74,42,692.00

*S. Srinivas*  
Accounts Officer 26/5/18

## Audited statement of Accounts

Sr. No.	Items	Budgeted	Actual Expenses
<b>2017-2018</b>			
1	Infrastructure Built Up	12,00,00,000.00	11,85,85,024.00
2	Library	2,00,000.00	3,51,024.00
3	Laboratory Equipments	0.00	0.00
4	Laboratory Consumables	1,50,000.00	4,16,767.00
5	Teaching & Non Teaching Staff Salary	13,00,00,000.00	13,87,01,705.00
6	Maintenance & Spares	50,00,000.00	38,04,047.00
7	R & D	0.00	0.00
8	Training & Travel	15,00,000.00	23,26,635.09
Total		25,68,50,000.00	26,41,85,202.09

*S. Srinivas*  
Accounts Officer 26/5/18

# [SELF ASSESSMENT REPORT]



## 10.4. Library and Internet

Application Deficiency Report

Application Status: Submitted  
 Application Sub-Status: Payment Received

2017-2018 EOP  
 Report Generated on: 20/04/2017

Type	Available	Required	Deficiency
Internet Bandwidth	100	48	No
Printers	52	29	No
A1 size Color Printers	1	0	No
Legal Application SW	28	20	No
Legal System SW	6	3	No
PCs to Student ratio	806	580	No

**Library Facilities**

Type	Available	Required	Deficiency
Volumes	25634	24500	No
Titles	4836	4550	No
National Journals	37	38	No
Library Management Software	1	1	No
Reading Room Capacity	165	150	No
MultiMediaPC	15	10	No

**Instructional Area-Common Facilities**

Type	Actual Room Area (Sq. m.)	Expected Room Area (Sq. m.)	Deficiency
Computer Center	181	150	No
Library & Reading Room	509	400	No

**Land Area Details**

Type	Actual Room Area (Acres)	Expected Room Area (Acres)	Deficiency
Total Area of Land	10.54	2.5	No
Maximum number of Pieces	1	2	No
Minimum per Piece of Area	10.54	2.5	No

**ENGINEERING AND TECHNOLOGY / Existing Programme**

Type	Level	Actual Room Area (Sq. m.)	Expected Room Area (Sq. m.)	Deficiency
Class Room- Tutorial Room	UNDER GRADUATE	4434	3366	No
Additional Workshop/Labs	UG/PG	800	800	No
Workshops	UG/PG	488	200	No
Drawing Halls	UG/PG	140	132	No
Seminar Hall	UG/PG	544	399	No
Laboratories-All	UG/PG	4825	3198	No

XX- No Rooms Available  
 DNA- Data Not Available / Inefficient Data  
 Blank Field-Data Not Entered  
 \* Laboratories required and Actual Number includes Total Number of Laboratories, Research Laboratories, and Additional WS/Labs for UG and PG courses, as applicable

20-02-2017  
 Date of Signature  
 (dd/mm/yyyy)



*V. R. [Signature]*  
 Name & signature of Director /Principal

\*\*Note :- All the Dates in the Report are in dd/mm/yyyy  
 Printed By: AICTEHELPT

# [SELF ASSESSMENT REPORT]



N W R 1 - 2 8 1 4 3 5 7 3 9 1 7 - 0 1 0 1 0 0 4

2016-2017

Type	Actual Room Area (Sq. m.)	Expected Room Area (Sq. m.)	Deficiency
Boys Common Room	88	75	No
Girls Common Room	89	75	No
Cafeteria	183	150	No
Stationery Store	15	10	No
First aid cum Sick Room	15	10	No

**Computational Facilities**

Type	Available	Required	Deficiency
Internet Bandwidth	65	48	No
Printers	61	56	No
A1 size Color Printers	1	0	No
Legal Application S/W	25	20	No
Legal System S/W	9	9	No
PCs to Student ratio	690	580	No

**Library Facilities**

Type	Available	Required	Deficiency
Volumes	23508	23000	No
Titles	4572	4000	No
National Journals	40	36	No
Library Management Software	1	1	No
Reading Room Capacity	165	150	No
MultiMediaPC	15	10	No

**Instructional Area-Common Facilities**

Type	Actual Room Area (Sq. m.)	Expected Room Area (Sq. m.)	Deficiency
Computer Center	161	150	No
Library & Reading Room	509	400	No

**Land Area Details**

Type	Actual Room Area (Acres)	Expected Room Area (Acres)	Deficiency
Total Area of Land	10.54	2.5	No
Maximum number of Pieces	1	2	No
Minimum per Piece of Area	10.54	2.5	No

**ENGINEERING AND TECHNOLOGY / Existing Programme**

Type	Level	Actual Room Area (Sq. m.)	Expected Room Area (Sq. m.)	Deficiency
Class Room- Tutorial Room	UNDER GRADUATE	5121	3287	No
Workshops	UG/PG	487	200	No
Drawing Halls	UG/PG	140	132	No
Seminar Hall	UG/PG	412	366	No
Laboratories-All	UG/PG	4525	3960	No

XX- No Rooms Available

DNA- Data Not Available / Insufficient Data

Blank Field-Data Not Entered

\* Laboratories required and Actual Number includes Total Number of Laboratories, Research Laboratories, and Additional WS/Labs for UG and PG courses, as applicable

^ Actual Number of Tutorial Rooms for Under Graduate includes the Number of Tutorial Rooms Available for PG, if applicable

\*\* Actual Number of Guest Rooms for Under Graduate includes the Actual Number of Guest Rooms Available for PG, if applicable

\*\*\* Actual Number of Kitchen for Under Graduate includes the Actual Number of Kitchen Available for PG, if applicable

सहायक लेखाधिकारी  
 इ.स. राज्य विद्यापीठ निर्माण प्राधिकरण  
 पारुड

V. R. Phadnis  
 2016



# [SELF ASSESSMENT REPORT]



The Principal  
JECRC, Jaipur

Sub: Budget proposal for the year 2018-2019

Dear Sir,

It is stated that the following expenditure is proposed to be made with regards to purchases of library books for the session 2018-2019

	<b>Amount</b>
Library Books	5,00,000
Journals / E-resources	2,50,000
News Papers & Periodicals	1,00,000
Computer (05) for Multimedia Library	<u>1,50,000</u>
<b>Total</b>	<b>10,00,000</b>

Approved  
Principal  
V. [Signature]

Amrita J  
Librarian 14/5/18



## [SELF ASSESSMENT REPORT]



The Principal  
JECRC, Jaipur

Sub: Budget proposal for the year 2017-2018

Dear Sir,

It is stated that the following expenditure is proposed to be made with regards to purchases of library books for the session 2017-2018

	<b>Amount</b>
Library Books	3,50,000
Journals / E-resources	2,50,000
News Papers & Periodicals	<u>1,00,000</u>
<b>Total</b>	<b>7,00,000</b>

  
Principal

Anita Jais  
14/5/18  
Librarian  

## [SELF ASSESSMENT REPORT]



The Principal  
JECRC, Jaipur

Sub: Budget proposal for the year 2016-2017

Dear Sir,

It is stated that the following expenditure is proposed to be made with regards to purchases of library books for the session 2016-2017 -

	<b>Amount</b>
Library Books	4,50,000
Journals / E-resources	1,50,000
News Papers & Periodicals	<u>1,00,000</u>
<b>Total</b>	<b>7,00,000</b>

  
Principal



## [SELF ASSESSMENT REPORT]



The Principal  
JECRC, Jaipur

Sub: Budget proposal for the year 2015-2016

Dear Sir,

It is stated that the following expenditure is proposed to be made with regards to purchases of library books for the session 2015-2016

	<b>Amount</b>
Library Books	4,50,000
Journals / E-resources	1,50,000
News Papers & Periodicals	<u>1,00,000</u>
<b>Total</b>	<b>7,00,000</b>

Principal



# [SELF ASSESSMENT REPORT]



## JECRC CENTRAL LIBRARY LIST OF JOURNALS (JAN. 2018 TO DEC. 2018)

S.No	Journals	Period	Cheques/DD in Favour of	Subscribed Rate	Periodicity
1	Indian Jour. Of Computer Science & Information Technology	1 Yr.	Global Research Pub. New Delhi-	3500/-	Half Yearly
2	Indian Jour. Of Control Science & Engineering	1 Yr.	Global Research Pub. New Delhi-	3500/-	Half Yearly
3	Indian Jour. Of Civil Mechanical Engineering	1 Yr.	Global Research Pub. New Delhi-	3500/-	Half Yearly
4	Indian Jour. Of Enrg. & Manufacturing Science	1 Yr.	Global Research Pub. New Delhi-	3500/-	Half Yearly
5	IETMA Journals	3 Yr.	IETMA Journals, Mumbai	2400/-	Monthly
6	University News	2 Yr.	Association of India University New Delhi	1700/-	Weekly
7	Digit	1 Yr.	Nine Dot, Nine Interactive Pvt. Ltd. Mumbai.	1899/-	Monthly
8	Electronics for You	2 Yr.	Ey Enterprises Pvt. Ltd. New Delhi	1150/-	Monthly
9	News for You	2 Yr.	Ey Enterprises Pvt. Ltd. New Delhi	2300/-	Monthly
10	Electronics Bazar	2 Yr.	Ey Enterprises Pvt. Ltd. New Delhi	1900/-	Monthly
11	Corporate India	2 Yr.	Corporate India Pub. Pvt. Ltd. Mumbai	2150/-	Fort-Nightly
12	Emerging Global Technology and Trends	1 Yr.	DELNET New Delhi	3540/-	Half Yearly
13	Indian Jour. Of Enrg. & Material Science	1 Yr.	NISCAIR, New Delhi	1600/-	Bio-Monthly
14	Indian Jour. Of Chemical Technology	1 Yr.	NISCAIR, New Delhi	1600/-	Bio-Monthly
15	Indian Jour. Of Bio - Chemistry & Bio-Physics	1 Yr.	NISCAIR, New Delhi	1900/-	Bio-Monthly
16	Indian Jour. Of Science and Industrial Research	1 Yr.	NISCAIR, New Delhi	3600/-	Monthly
17	Indian Jour. Chemistry Sec-A	1 Yr.	NISCAIR, New Delhi	4600/-	Monthly
18	Indian Jour. Of Pure & Applied Physics	1 Yr.	NISCAIR, New Delhi	3200/-	Monthly
19	Annual of Library & Information Science <i>Spajdies.</i>	1 Yr.	NISCAIR, New Delhi	1200/-	Quarterly



# [SELF ASSESSMENT REPORT]



**JECRC LIBRARY**  
**NAME OF JOURNALS (10.10.2015)**

Sr. No.	Name of Journals	Period	Cheque/D.D. In Favour of.	Subscription Rate	Periodicity
1	Indian Jour. Of Engg. & Material Science	1 Year	NISCAIR, New Delhi	1600/-	Bio-Monthly
2	Indian Jour. Of Chemical Technology	1 Year	NISCAIR New Delhi	1600/-	Bio-Monthly
3	Indian Jour. Of Bio Chemistry & Bio Physics	1 Year	NISCAIR New Delhi	1900/-	Monthly
4	Indian Jour. Of Scientific and Industrial Research	1 Year	NISCAIR New Delhi	3600/-	Monthly
5	Indian Jour. Of Chemistry Sec-A	1 Year	NISCAIR New Delhi	4600/-	Monthly
6	Indian Jour. Of Pure & Applied Physics	1 Year	NISCAIR New Delhi	3200/-	Monthly
7	Annual of Library & Information Studies	1 Yr.	NISCAIR New Delhi	1200/-	Quarterly
8	Jour. On Electrical Engg.	1 Year	Subscription Centre, Ahmedabad	2200/-	Quarterly
9	Jour. On Electronics Engg.	1 Year	Subscription Centre, Ahmedabad	2200/-	Quarterly
10	Jour. On Mechanical Engg.	1 Year	Subscription Centre, Ahmedabad	2200/-	Quarterly
11	Jour. On Civil Engg.	1 Year	Subscription Centre, Ahmedabad	2200/-	Quarterly
12	Jour. On Wireless Communication Networks	1 Year	Subscription Centre, Ahmedabad	2200/-	Quarterly
13	Jour. Of Cloud Computing	1 Year	Subscription Centre, Ahmedabad	2200/-	Quarterly
14	Power Engineer Journals	1 Year	Indian Journals, con New Delhi	900/-	Half Yearly
15	Indian Jour. Of Computer Science & Information Technology	1 Year	Global Research Pub. New Delhi	3500/-	Half Yearly
16	Indian Jour. Of Control Science & Engineering	1 Year	Global Research Pub. New Delhi	3500/-	Half Yearly
17	Indian Jour. Of Civil Mechanical Engg.	1 Year	Global Research Pub. New Delhi	3500/-	Half Yearly
18	Indian Jour. of Adv. Of Fuzzy System	1 Year	Global Research Pub. New Delhi	3500/-	Half Yearly
19	Indian Jour. Of Engg. & Manufacturing Science	1 Year	Global Research Pub. New Delhi	3500/-	Half Yearly
20	Int. Jour. Of Computer Science & Engg. Technology	1 Year	Subscription Centre, Ahmedabad	3500/-	Half Yearly
21	Int. Jour. Of Advance in Software Engg.	1 Year	Subscription Centre, Ahmedabad	3500/-	Half Yearly
22	Int. Jour. Of Electrical Engg. & Electronics System Research	1 Year	Subscription Centre, Ahmedabad	3500/-	Half Yearly
23	Int. Jour. Of Mechanical Automobile Engg. & Research	1 Year	Subscription Centre, Ahmedabad	3500/-	Half Yearly
24	Int. Jour. Of VLSI Design	1 Year	Subscription Centre, Ahmedabad	3000/-	Half Yearly
25	Int. Jour. Of Civil & Building Engineering	1 Year	Subscription Centre, Ahmedabad	3500/-	Half Yearly
26	Flight	1 Yr.	Nine Dot nine Interactive Pvt. Ltd. Mumbai	1609/-	Monthly
27	Grantthalaya Vidyayan	1Yr.	Sampadak Grantthalaya Vidyayan Jaipur	375/-	Monthly

10.4.1. Quality of learning resources

Relevance of available learning resources including e-resources

Accessibility to students

Support to students for self-learning activities

CENTRAL LIBRARY  
BOOKS ISSUE DETAILS  
Books Circulation (Issue) Details-2017-2018

Month	"A" Block Library Issue	"C" Block Library Issue
July-2017	1578	113
August-2017	2892	1042
September-2017	3071	1163
October-2017	1845	603
November-2017	2693	966
December-2017	1431	600
January-2018	1635	507
February-2018	1863	579
March-2018	838	223
April-2018	1745	585
May-2018	1026	478
June-2018	---	---
<b>Total</b>	<b>20617</b>	<b>6859</b>
<b>Average Per Month Books Issued</b>	<b>1718</b>	<b>571</b>



# [SELF ASSESSMENT REPORT]



**CENTRAL LIBRARY  
BOOKS ISSUE DETAILS  
Books Circulation (Issue) Details-2016-2017**

Month	"A" Block Library Issue	"C" Block Library Issue
July-2016	840	72
August-2016	2571	98
September-2016	1806	458
October-2016	1738	469
November-2016	1822	669
December-2016	893	340
January-2017	2547	987
February-2017	2022	630
March-2017	937	237
April-2017	1389	401
May-2017	814	290
June-2017	10	--
<b>Total</b>	<b>17389</b>	<b>4651</b>
<b>Average Per Month Books Issued</b>	<b>1449</b>	<b>387</b>



# [SELF ASSESSMENT REPORT]



## CENTRAL LIBRARY BOOKS ISSUE DETAILS Books Circulation (Issue) Details-2015-2016

Month	"A" Block Library	"C" Block Library
	Issue	Issue
July-2015	1438	57
August-2015	2916	145
September-2015	2713	1005
October-2015	2269	650
November-2015	2063	493
December-2015	2041	952
January-2016	2054	568
February-2016	2679	1062
March-2016	1784	595
April-2016	1553	384
May-2016	1634	597
June-2016	762	322
<b>Total</b>	<b>23906</b>	<b>6830</b>
<b>Average Per Month Books Issued</b>	<b>1992</b>	<b>569</b>



**DETAILS OF LIBRARY BOOKS FOR LAST 3 YEARS AS PER AICTE**

	No of Titles		No. of Volume	
	Required	Available	Required	Available
2015-2016	4400	4572	23000	23588
2016-2017	4550	4836	24500	25694
2017-2018	4850	6071	24500	33908 Including 'e' Books

*Andy An*  
 11/5/18  
**LIBRARIAN**  
 Jaipur Engineering Coll  
 And Research Centre  
 Jaipur

# [SELF ASSESSMENT REPORT]



## E-Books Detail

Tovindra Kumar Sahu <tvindra@jecrc.ac.in>

to principal, Bhavna, Bhuvnesh, CS, dhrd, Vijay, Dr.Manish, EE, HoD, HoD, HoD, HoD, HoD, HoD, HoD, HoD, Kamlesh, P

May 17

English Esperanto Translate message

Turn off for: English

Dear Sir/Madam,

Please find ebooks detail in JECRC:

### E Books

S.No.	Department	No. Of Ebooks
1.	CSE	2851
2.	IT	1677
3.	ECE	1419
4.	Civil	635
5.	ME	469
6.	EE	554
7.	Phy	500
Total		8105

### Login Detail:

<http://192.168.100.6>

User Name : ebooks

Password : ebooks

Thanks & Regards

Tovindra Kumar Sahu

Senior Lab Instructor, Jaipur Engineering College & Research Center,  
Jaipur

P +91-141-2770232 Ext. 209, 211 M 09980186878, 09214068878

## 10.4.2. Internet

Name of the Internet provider: VODAFONE

Available bandwidth: 150Mbps

Wi Fi availability: YES

Internet access in labs, classrooms, library and offices of all Departments: YES

Security arrangements: Yes

# [SELF ASSESSMENT REPORT]



**INTERNET**

**NAME OF THE INTERNET PROVIDER: VODAFONE**

**AVAILABLE BANDWIDTH: 150 Mbps**

**Wi-Fi AVAILABLE: Yes**

**Internet access in labs, classrooms, Library and offices of all Departments: Yes**

**Security arrangements: Yes**

31/5/2018

### 12. FACILITIES AND AMENITIES

Monetary Status of Activities(Amount in lac)	Last 365 days	Purchased Value this Year	Total Value
Name of the Central Facility	Qty/Capacity		
Warm coolant/storage capacity	2000	0	As Per Balance Sheet
Water Purifier(capacity L/day)	2000	0	As Per Balance Sheet
Generator Set(KW)	325 K.V.A.	0	As Per Balance Sheet
Air conditioning cap.	462	0	As Per Balance Sheet
Tv no. of units	3	0	As Per Balance Sheet
Audio System no. of units	3	0	As Per Balance Sheet
Photo copier/Not Interfacible	3	0	As Per Balance Sheet

### 13. COMPUTER/PERIPHERALS/NETWORK

Computer/Peripherals/Network	Qty	Purchased value this year	Total value
Computers for office purpose only	26	0	AS PER BALANCE SHEET
Desktop/laptop computers	706	0	AS PER BALANCE SHEET
Thin clients/slave computers	0	0	AS PER BALANCE SHEET
Servers	5	0	AS PER BALANCE SHEET
Printers	55	0	AS PER BALANCE SHEET
Scanners	2	0	AS PER BALANCE SHEET
Cameras No. of units	0	0	AS PER BALANCE SHEET
Other Peripheral devices	0	0	AS PER BALANCE SHEET
Internet Connection(speed mbps)	105	0	AS PER BALANCE SHEET
System Softwares	8	0	AS PER BALANCE SHEET
Application Softwares	28	0	AS PER BALANCE SHEET
Computers networked so far	868	0	AS PER BALANCE SHEET

### 14. CAMPUS SELECTION DETAIL

Name & Address of Company	Offer Amount(Lacs)	Placed This year
Accenture Services Pvt Ltd. Building No. 1A & 1B, Raheja Mind Space, Hitech City, Madhapur, Hyderabad, Telangana 500086	3.50	68
PINNACLE INFOTECH	2.40	49
Cause Code	5.00	2
TCS	3.50	15
Arttech Infosystem	2.50	12
Newgen Software	4.25	8
Matrix consoc	3.00	10
Ray Gauri Project	2.20	9
In time Tec	2.20	2
Info C Services	1.50	1
	2.20	2

# [SELF ASSESSMENT REPORT]



## Jaipur Engineering College & Research Center, Jaipur

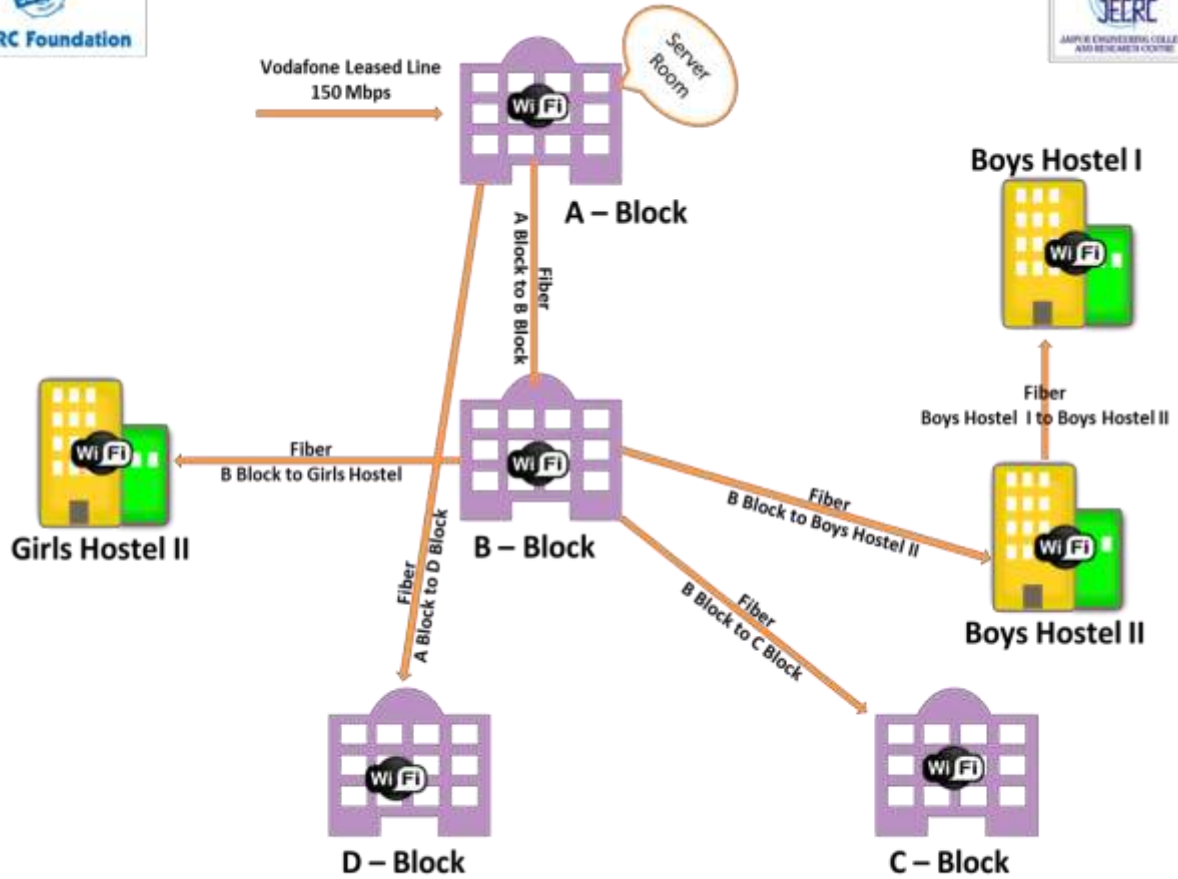

Network Diagram

# [SELF ASSESSMENT REPORT]



Part C

Declaration by the Institution

  
JAIPUR ENGINEERING COLLEGE  
AND RESEARCH CENTRE

Ref: JECRC/REG/2018-19/181 Date: 11/09/2018

**Declaration**

I undertake that, the institution is well aware about the provisions in the NBA's accreditation manual concerned for this application, rules, regulations, notifications and NBA expert visit guidelines in force as on date and the institute shall fully abide by them.

It is submitted that information provided in this Self-Assessment Report is factually correct. I understand and agree that an appropriate disciplinary action against the Institute will be initiated by the NBA, in case any false statement/information is observed during pre-visit, visit, post visit and subsequent to grant of accreditation.

Date: 11/9/18  
Place: Jaipur

V. @aur  
Signature & Name  
Head of the Institution with seal



 **JECRC Foundation**  
www.jecrcfoundation.com

Jaipur Engineering College and Research Centre  
Approved by AICTE & Affiliated to RTU  
JECRC Campus, Shri Ram Ki Nangal,  
Via Sitapura Bypass, Opp. EPIP Gate, Tonk Road, Jaipur 302 022  
t: 0141 2770120, 2770232 e: info@jecrcmail.com





## **ANNEXURE I:**

### **(A) PROGRAM OUTCOMES (POs)**

Engineering Graduates will be able to:

1. **Engineering knowledge:** Apply the knowledge of mathematics, science, engineering fundamentals, and an engineering specialization to the solution of complex engineering problems.
2. **Problem analysis:** Identify, formulate, review research literature, and analyze complex engineering problems reaching substantiated conclusions using first principles of mathematics, natural sciences, and engineering sciences.
3. **Design/development of solutions:** Design solutions for complex engineering problems and design system components or processes that meet the specified needs with appropriate consideration for the public health and safety, and the cultural, societal, and environmental considerations.
4. **Conduct investigations of complex problems:** Use research-based knowledge and research methods including design of experiments, analysis and interpretation of data, and synthesis of the information to provide valid conclusions.
5. **Modern tool usage:** Create, select, and apply appropriate techniques, resources, and modern engineering and IT tools including prediction and modeling to complex engineering activities with an understanding of the limitations.
6. **The engineer and society:** Apply reasoning informed by the contextual knowledge to assess societal, health, safety, legal and cultural issues and the consequent responsibilities relevant to the professional engineering practice.
7. **Environment and sustainability:** Understand the impact of the professional engineering solutions in societal and environmental contexts, and demonstrate the knowledge of, and need for sustainable development.
8. **Ethics:** Apply ethical principles and commit to professional ethics and responsibilities and norms of the engineering practice.
9. **Individual and team work:** Function effectively as an individual, and as a member or leader in diverse teams, and in multidisciplinary settings.
10. **Communication:** Communicate effectively on complex engineering activities with the engineering community and with society at large, such as, being able to comprehend and write effective reports and design documentation, make effective presentations, and give and receive clear instructions.
11. **Project management and finance:** Demonstrate knowledge and understanding of the engineering and management principles and apply these to one's own work, as a member and leader in a team, to manage projects and in multidisciplinary environments.

## [SELF ASSESSMENT REPORT]

---



12. Life-long learning: Recognize the need for, and have the preparation and ability to engage in independent and life-long learning in the broadest context of technological change.

### (B) PROGRAM SPECIFIC OUTCOMES (PSOs)

Program shall specify 2-4 program specific outcomes.